

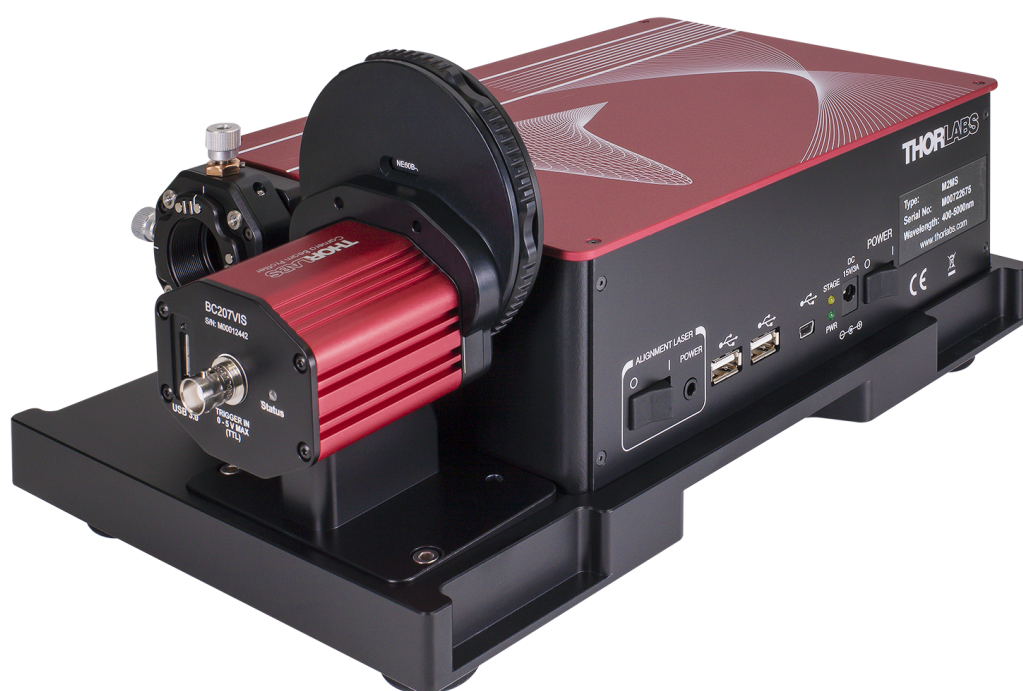

BC207UV(/M), BC207VIS(/M), and
BC210CU(/M), BC210CV(/M)
with M2MS(-AL)

Camera Beam Profiler

User Guide



2023

Version: 8.2
Date: 14-Aug-2023

Table of Contents

Chapter 1	Safety	1
Chapter 2	Intended Use	3
Chapter 3	Introduction	4
3.1	Ordering Codes and Accessories	4
3.2	Requirements	5
Chapter 4	Getting Started	5
4.1	Parts List BC207UV(/M) and BC207VIS(/M)	6
4.2	Parts List BC210CU(/M) and BC210CV(/M)	6
Chapter 5	Operation Instructions	6
5.1	Operating Elements	6
5.1.1	BC207 and BC210C Series	6
5.1.1.1	Operating Elements BC207 Series	6
5.1.1.2	Operating Elements BC210C Series	8
5.1.1.3	Filter Wheel	9
5.1.1.4	Change Filter Wheel	12
5.1.1.5	Status LED	15
5.1.1.6	CMOS Sensor Protective Glass Window	15
5.1.1.7	Trigger Input	15
5.1.1.8	Mounting BC207 Series	16
5.1.1.9	Mounting BC210C Series	17
5.1.2	Camera Beam Profiler Series with M2MS Extension Set	18
5.1.2.1	Operating Elements M2MS	18
5.1.2.2	Mounting BC207 Series on M2MS(-AL)	19
5.1.2.3	Mounting BC210C Series on M2MS(-AL)	21
5.2	Setup BC207 and BC210C Series	23
5.3	Installation	23
5.3.1	Software Installation	23
5.3.2	Connection to the PC	24
5.3.3	Start the Application	25
5.4	The Graphics User Interface (GUI)	27
5.4.1	Menu Bar	27
5.4.1.1	File Menu	28
5.4.1.2	Control Menu	29
5.4.1.3	Options Menu	30

5.4.1.4	Windows Menu	33
5.4.1.5	View Menu	33
5.4.1.6	Help Menu	34
5.4.2	Tool Bar	34
5.4.3	Status Bar	36
5.4.4	Save Settings	36
5.4.5	Beam Settings	36
5.4.5.1	Optical Setup	38
5.4.5.1.1	Wavelength	38
5.4.5.1.2	Attenuation	38
5.4.5.1.3	Power Correction	38
5.4.5.1.4	Ambient Light Correction	38
5.4.5.1.5	Intensity Threshold	38
5.4.5.2	Beam Profiler Information	42
5.4.5.3	Camera Beam Profiler Parameter	43
5.4.5.3.1	Binning	43
5.4.5.3.2	Exposure Control	43
5.4.5.3.3	Gain Control	43
5.4.5.3.4	Hot Pixel Correction	43
5.4.5.3.5	Trigger	43
5.4.5.3.6	Region of Interest	43
5.4.5.4	Calculation Parameter	50
5.4.5.4.1	Calculation Area	50
5.4.5.4.2	Averaging Mode	50
5.4.5.4.3	Clip Level	50
5.4.5.4.4	Hold Maximum	50
5.4.5.4.5	Approximate Ellipse	50
5.4.5.4.6	Autoscale to Peak	50
5.4.5.4.7	Profile Cut Position	50
5.4.5.4.8	Reference Position	50
5.4.5.4.9	Unit	50
5.4.5.5	Plot Over Time Parameter	54
5.4.5.6	Translation Stage Control	55
5.4.6	Child Windows	57
5.4.6.1	2D Projection	58
5.4.6.2	3D Profile	61
5.4.6.3	X and Y Profiles	62
5.4.6.4	Zooming and Panning Diagrams	63
5.4.6.5	Calculation Results	64
5.4.6.6	Manual Vergence Measurement	68

5.4.6.7	Tuning View	70
5.4.6.8	Beam Overlapping	72
5.4.6.9	Plots	74
5.4.6.9.1	Plot Positions	74
5.4.6.9.2	Plot Power	74
5.4.6.9.3	Plot Diameters	74
5.4.6.9.4	Plot Gaussian Fit	74
5.4.6.9.5	Plot Orientation	74
5.4.6.9.6	Plot Environment Data	74
5.4.6.9.7	Beam Stability	74
5.5	Measurement with the Beam Profiler	83
5.5.1	Operating the Instrument	83
5.5.2	Pass/Fail Test	85
5.5.3	Save Measurement Results	87
5.5.3.1	Export Device Data	87
5.5.3.2	Print Windows	90
5.5.3.3	Save Test Protocol	91
5.6	Beam Quality (M²) Measurement	92
5.6.1	General	92
5.6.2	M2MS Operating Principle	94
5.6.3	Beam Diameter Requirements	95
5.6.4	M ² Meter Extension Set	96
5.6.5	Setup M2MS	96
5.6.5.1	Mounting the Beam Profiler	98
5.6.5.2	Connecting M2MS to the PC	99
5.6.6	M ² Measurement	100
5.6.6.1	Beam Alignment	101
5.6.6.1.1	Coarse Alignment	101
5.6.6.1.2	Fine Alignment	101
5.6.6.1.2.1	M ² Beam Alignment Wizard	101
5.6.6.1.2.2	Alignment of the Focusing Lens	101
5.6.6.2	M ² Measurement Panel	111
5.6.6.3	M ² Settings	114
5.6.6.4	Saving the M ² Measurement Results	116
5.6.6.4.1	Saving M ² Test Results	116
5.6.6.4.2	Saving Beam Profile Data During M ² Measurement	116
5.6.6.5	Running the M ² Measurement	119
5.6.6.6	M ² Measurement Results	120
5.6.6.7	M ² Troubleshooting	125
5.6.6.8	Live Adjustment	128

5.6.7	Divergence Measurement	129
5.6.7.1	Beam Alignment	129
5.6.7.1.1	Coarse Alignment	129
5.6.7.1.2	Fine Alignment	129
5.6.7.1.3	Divergence Beam Alignment Wizard	129
5.6.7.2	Divergence Measurement Panel	137
5.6.7.3	Divergence Measurement Settings	139
5.6.7.4	Saving the Divergence Measurement Results	140
5.6.7.5	Running the Divergence Measurement	140
5.6.7.6	Divergence Measurement Results	141
5.6.7.7	Live Adjustment	142
5.6.8	M ² Theory	143
Chapter 6	Write Your Own Application	146
6.1	32 bit Operating System	147
6.2	64 bit Operating System	149
Chapter 7	Specifications BC207x and BC210Cx	152
7.1	Dimensions BC207UV(/M) and BC207VIS(/M)	155
7.2	Dimensions BC210CU(/M) and BC210CV(/M)	156
7.3	Specifications Filter Wheel	157
7.4	Wavelength Response	158
7.5	Power Ranges	159
Chapter 8	Specifications M2MS Extension Sets	161
Chapter 9	Initial Software Settings	162
Chapter 10	Maintenance and Service	162
10.1	Version	163
10.2	Cleaning	163
10.3	Troubleshooting	164
10.3.1	Warnings and Errors	165
Chapter 11	Compatibility with Older Hardware	166
Chapter 12	List of Acronyms	167
Chapter 13	Application Note	168
13.1	Ambient Light Correction	168
13.2	Coordinate Systems	168
13.3	Raw Data Measurements	169
13.4	Ellipse (Fitted)	171
13.5	X-Y-Profile Measurement	171
13.6	Gaussian Fit Measurement	172

13.7	Bessel Fit	172
Chapter 14	Certifications and Compliances	173
Chapter 15	Warranty and RMA Information	175
15.1	Return of Devices	175
15.2	WEEE Policy	175
Chapter 16	Manufacturer Address	175
Chapter 17	Copyright and Exclusion of Liability	176
Chapter 18	Thorlabs Worldwide Contacts	177

Chapter 1 Safety

Attention

The safety of any system incorporating the equipment is the responsibility of the assembler of the system.

All statements regarding safety of operation and technical data in this instruction manual will only apply when the unit is operated correctly as it was designed for.

The BC207 and BC210C Series must not be operated in explosion endangered environments!

Do not obstruct the air ventilation slots in the housing!

Do not remove covers!

Do not open the cabinet. There are no user-serviceable parts inside!

This precision device is only serviceable if returned and properly packed into the complete original packaging including the cardboard inserts. If necessary, ask for replacement packaging.

Refer servicing to qualified personnel!

Changes to this device cannot be made nor may components not supplied by Thorlabs be used without written consent from Thorlabs.

Attention

Prior to applying power to the BC207 and BC210C Series, make sure that the protective conductor of the 3 conductor mains power cord is correctly connected to the protective earth ground contact of the socket outlet! Improper grounding can cause electric shock resulting in damage to your health or even death!

All modules must only be operated with duly shielded connection cables.

Attention

The following statement applies to the products covered in this manual, unless otherwise specified herein. The statement for other products will appear in the respective accompanying documentation.

Note This equipment has been tested and found to comply with the limits for a Class A digital device, pursuant to part 15 of the FCC Rules and meets all requirements of the Canadian Interference-Causing Equipment Standard ICES-003 for digital apparatus. These limits are designed to provide reasonable protection against harmful interference when the equipment is operated in a commercial environment. This equipment generates, uses, and can radiate radio frequency energy and, if not installed and used in accordance with the instruction manual, may cause harmful interference to radio communications. Operation of this equipment in a residential area is likely to cause harmful interference in which case the user will be required to correct the interference at his own expense.

Users that change or modify the product described in this manual in a way not expressly approved by Thorlabs (party responsible for compliance) could void the user's authority to operate the equipment.

Thorlabs is not responsible for any radio television interference caused by modifications of this equipment or the substitution or attachment of connecting cables and equipment other than those specified by Thorlabs. The correction of interference caused by such unauthorized modification, substitution or attachment will be the responsibility of the user.

The use of shielded I/O cables is required when connecting this equipment to any and all optional peripheral or host devices. Failure to do so may violate FCC and ICES rules.

This product has been tested and found to comply with the limits according to IEC 61326-1 for using connection cables shorter than 3 meters (9.8 feet).

The instrument must only be operated with a duly shielded and low resistance USB cable delivered by Thorlabs.

Attention

Do not stick anything into the input aperture of the Camera Beam Profilers! You may damage the neutral density (ND) optical attenuation filter.

Attention

The M2MS and M2MS-AL M² Measurement System comes with an alignment laser that is powered by a M2MS and M2MS-AL internal driver. Be careful when using this laser!

Laser modules can deliver up to several 0.4 mW of even invisible laser radiation! When operated incorrectly, this can cause severe damage to your eyes and health! Be sure to pay strict attention to the safety recommendations of the appropriate laser safety class, as stated for the used light source.

The device is a class 1 laser sources.



Chapter 2 Intended Use

The BC207 and BC210C Camera Beam Profiler measures the shape, size and position of laser beams. They are used in photonics research and development applications.

The BC207 and BC210C Camera Beam Profilers are designed for laboratory use only. These products may not be used or integrated into equipment that is applied in pharmaceutical, medical, or military applications. Thorlabs, Inc. Life Support and Military Use Application Policy is stated below:

THORLABS' PRODUCTS ARE NOT AUTHORIZED FOR USE AS CRITICAL COMPONENTS IN LIFE SUPPORT DEVICES OR SYSTEMS OR IN ANY MILITARY APPLICATION WITHOUT THE EXPRESS WRITTEN APPROVAL OF THE PRESIDENT OF THORLABS, INC. As used herein:

1. Life support devices or systems are devices or systems which, (a) are intended for surgical implant into the body, or (b) support or sustain life, and whose failure to perform, when properly used in accordance with instructions for use provided in the labeling, can be reasonably expected to result in a significant injury to the user.
2. A critical component is any component in a life support device or system whose failure to perform can be reasonably expected to cause the failure of the life support device or system or to affect its safety or effectiveness.
3. The Thorlabs products described in this document are not intended nor warranted for usage in Military Applications.

Chapter 3 Introduction

The BC207UV(/M), BC207VIS(/M), BC210CU(/M), and BC210CV(/M) Camera Beam Profilers allow identification of complex mode patterns (like flat top and donut) while optimizing a laser system. Compared to scanning slit beam profilers like the Thorlabs [BP209 Series](#), Camera Beam Profilers capture a more detailed beam profile and provide a true 2D analysis of the beam's power density distribution. Compared to the BC207 Series, the BC210C Series has a larger camera chip, resulting in a higher resolution, and a smaller camera housing.

The Thorlabs BC207UV(/M), or BC210CU(/M), camera beam profilers are suited for use within the UV range. The BC207VIS(/M) and BC210CV(/M) are optimized for applications in the visible light range. The high resolution in a large field of view and the thermal stability make the BC207 and BC210C Camera Beam Profilers a superior product. Several trigger modes allow flexible capturing of beam profiles from pulsed light sources. This includes a TTL input for triggered pulse detection of signals.

The BC207 and BC210C series camera beam profilers can be purchased in an imperial version (BC207UV, BC207VIS, BC210CU, or BC210CV) and in a metric version (BC207UV/M, BC207VIS/M, BC210CU/M, or BC210CV/M). For the purpose of this manual, BC207UV(/M), BC207VIS(/M), BC210CU(/M), or BC210CV(/M) refers to all versions, respectively.

The Beam Software versions 8.0 and higher support all features for a full beam analysis with the BC207 Series Camera Beam Profiler. BC210C Series requires software version 9.0 or higher.

The Beam Software is provided for download from the software tab on the [Thorlabs BC207 and BC210C website](#). With the integrated power meter, the power and beam shape can be observed through the software simultaneously. To compensate for ambient light, a measured mean value of the ambient light intensity is subtracted from the beam profile measurement. The automatic exposure and gain control feature adapts the camera settings to the actual beam intensity. The USB 3.0 interface allows for a high frame rate. Measurements at very high frame rates can be transferred with reduced frame sizes.

To convert Thorlabs camera beam profilers into a fully-automated M² measurement system, Thorlabs offers the [M2MS\(-AL\) extension sets](#). For more information please contact Thorlabs [technical support](#).

3.1 Ordering Codes and Accessories

BC207UV	CMOS Camera Beam Profiler, 245 - 400 nm Wavelength Range, Ø20 µm - Ø7.0 mm Beam Diameter, Imperial Mounting
BC207UV/M	CMOS Camera Beam Profiler, 245 - 400 nm Wavelength Range, Ø20 µm - Ø7.0 mm Beam Diameter, Metric Mounting
BC207VIS	CMOS Camera Beam Profiler, 350 - 1100 nm Wavelength Range, Ø20 µm - Ø7.0 mm Beam Diameter, Imperial Mounting
BC207VIS/M	CMOS Camera Beam Profiler, 350 - 1100 nm Wavelength Range, Ø20 µm - Ø7.0 mm Beam Diameter, Metric Mounting
BC210CU	CMOS Camera Beam Profiler, 245 - 400 nm Wavelength Range, Ø20 µm - Ø10.0 mm Beam Diameter, Imperial Mounting
BC210CU/M	CMOS Camera Beam Profiler, 245 - 400 nm Wavelength Range, Ø20 µm - Ø10.0 mm Beam Diameter, Metric Mounting
BC210CV	CMOS Camera Beam Profiler, 350 - 1100 nm Wavelength Range, Ø20 µm - Ø10.0 mm Beam Diameter, Imperial Mounting
BC210CV/M	CMOS Camera Beam Profiler, 350 - 1100 nm Wavelength Range, Ø20 µm - Ø10.0 mm Beam Diameter, Metric Mounting

For beam quality (M^2) measurements, Thorlabs offers M2MS hardware extension sets to BC207 Series, BC210C Series, and BP209 Series, as well as complete M^2 Measurement Systems consisting of M2MS and BP209 Series beam profilers. The M2MS extension sets can be purchased through the [M2MS website](#).

Recommended Accessories:

A mounting adapter for the former BC106N-UV(/M) or BC106N-VIS(/M) Camera Beam Profilers can be purchased by contacting [Thorlabs](#) directly.

To purchase the above products, please visit our homepage <http://www.thorlabs.com>. For further information or custom made solutions, please contact our [technical support](#).

3.2 Requirements

The requirements for using a PC to operate the BC207 and BC210C Series Camera Beam Profilers are given below. The BC207 Series requires Thorlabs Beam Software Version 8.0 or higher and the BC210C Series requires Version 9.0 or higher. Please find the BEAM Software for download from the [Beam Software website](#).

Hardware Requirements

- Processor (CPU): ≥ 3.0 GHz Intel Core (i5 or Higher)¹
- Memory (RAM): 4.0 GB
- Graphic Card Resolution: OpenGL (specification GLX 1.3 up) compatible graphics adapter:
 - Radeon (X100 series \geq X850, X1000 series \geq X1600, HD series \geq 2400)
 - Geforce 7 series \geq 7600, 8 series \geq 8500, 9 series \geq 9600
 - Quadro FX series \geq FX770M
- Hard Drive: Min. 2 GB of available disk space
- Interface: Free high-speed USB 3.0 port
- Monitor resolution minimum 1024 x 758 pixel (\geq 16 bit color depth)

¹Intel Core i3 processors and mobile versions of Intel processors may not satisfy the requirements.

The Thorlabs Beam Software is compatible with the following operating systems:

- Windows[®] 11 (for Beam Software Version 9.0 or Higher)
- Windows[®] 10 (32-bit or 64-bit)
- Windows[®] 8.1 (32-bit or 64-bit)

Recommended for Optimal Performance:

- USB 3.0 high speed port
- Processor: Intel Core 2 i5 or AMD Ryzen 5 (min. 3.0 GHz), 8.0 GB RAM
- OpenGL (specification GLX 1.3 up) compatible graphics adapter:
 - Radeon HD series \geq 7000
 - Geforce GTX series \geq 500

Chapter 4 Getting Started

Please inspect the shipping container for damage. Please do not cut through the cardboard. You might need the box for storage or for returns.

If the shipping container seems to be damaged, keep it until you have inspected the contents for completeness and tested the BC207 and BC210C Series device mechanically and electrically.

Verify that you have received the following items within the package:

4.1 Parts List BC207UV(/M) and BC207VIS(/M)

BC207UV(/M) or BC207VIS(/M) Beam Profiler

- 1 BC207UV(/M) or BC207VIS(/M) Beam Profiler Instrument with Mounted Filter Wheel
- 6 Mounted Attenuation Filters, See Section [Filter Wheel](#)^[157] for Further Information
- 1 Snap-On Dust Cap
- [CABU31](#): USB 3.0 A to Micro B Cable, Length: 3 m
- Quick Reference

4.2 Parts List BC210CU(/M) and BC210CV(/M)

BC210CU(/M) or BC210CV(/M) Beam Profiler

- 1 BC210CU(/M) or BC210CV(/M) Beam Profiler Instrument with Mounted Filter Wheel
- 6 Mounted Attenuation Filters, See Section [Filter Wheel](#)^[157] for Further Information
- 1 Snap-On Dust Cap
- [CABU32](#): USB 3.0 A to Right-Angle Micro B Cable, Length: 3 m
- 1 Screwdriver to tighten the Locking Screw of the USB 3.0 Cable
- Quick Reference

Chapter 5 Operation Instructions

5.1 Operating Elements

5.1.1 BC207 and BC210C Series

5.1.1.1 Operating Elements BC207 Series

The components of the BC207UV are labeled in the image below. Aside from the mounting thread, BC207UV and BC207UV/M are identical. BC207VIS and BC207VIS/M outer dimensions and components look identical to BC207UV and BC207UV/M. BC207VIS(/M) differs in the mounted filters and the protection glass.

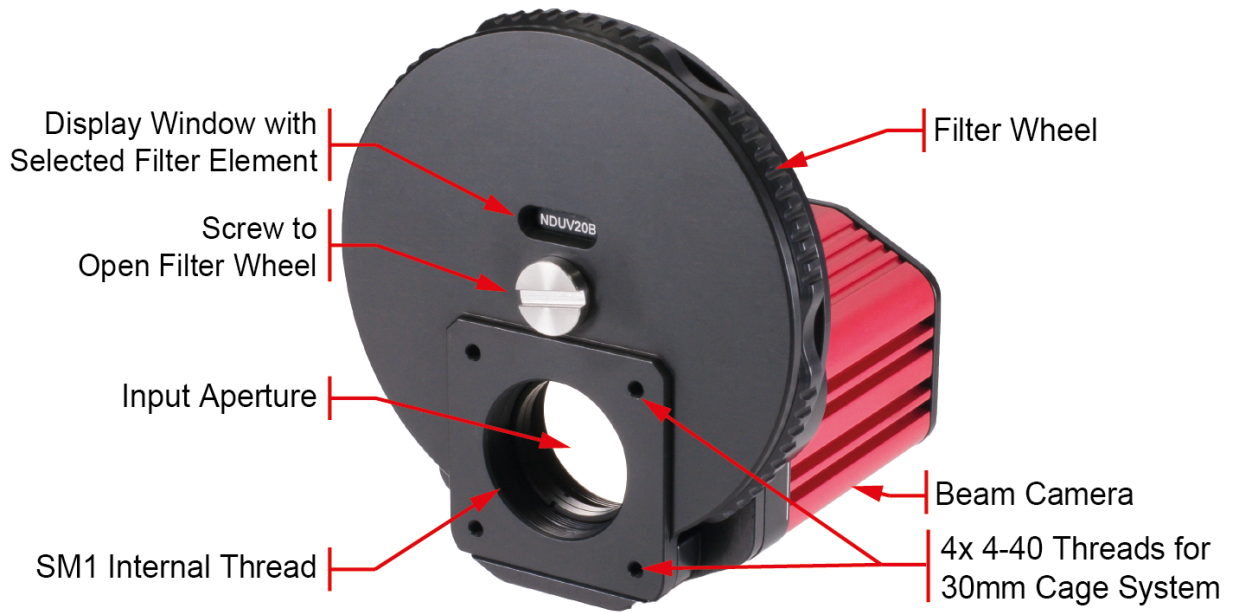

BC207UV

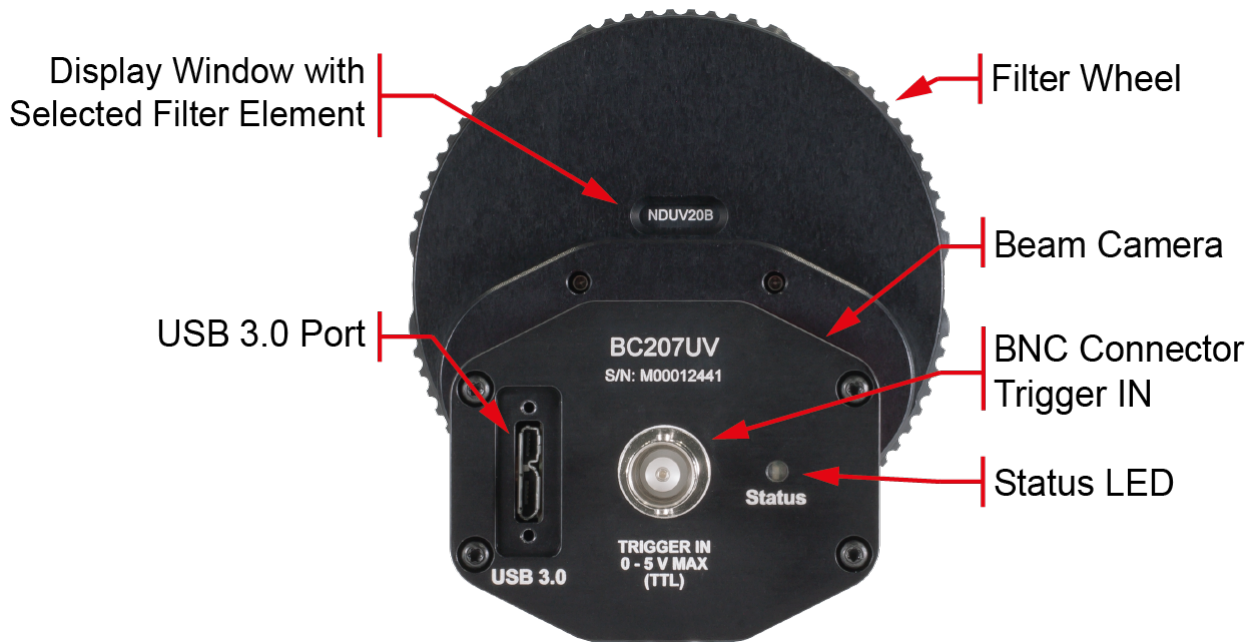

5.1.1.2 Operating Elements BC210C Series

The components of the BC210CU are labeled in the image below. Aside from the mounting thread, BC210CU and BC210CU/M are identical. BC210CV and BC210CV/M outer dimensions and components look identical to BC210CU and BC210CU/M. BC210CV(/M) differs in the mounted filters and the protection glass.

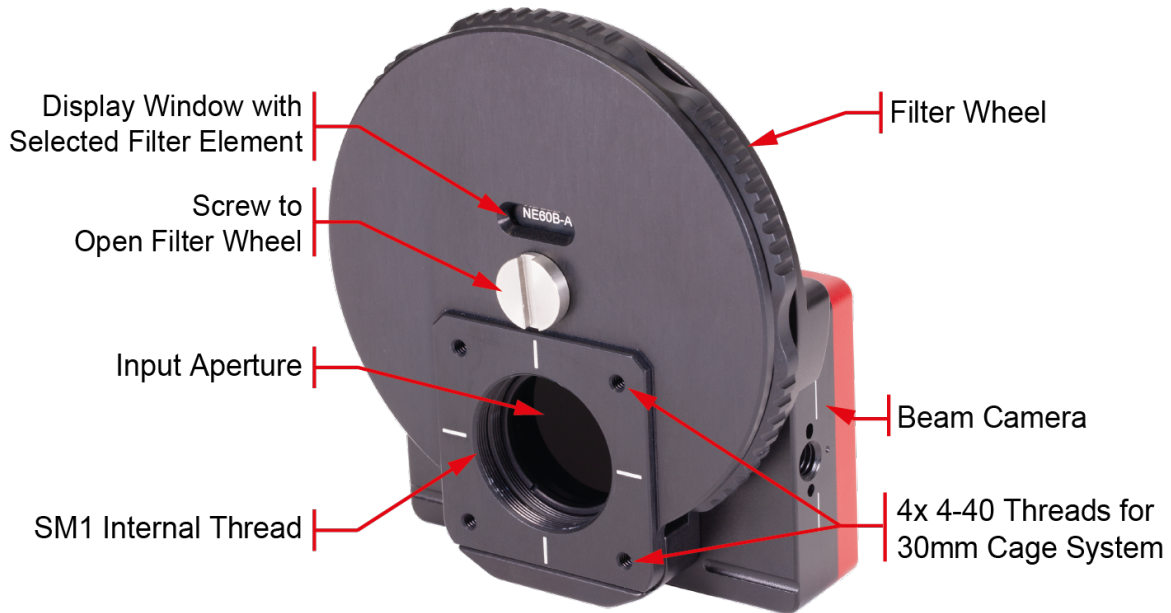

BC210CU



5.1.1.3 Filter Wheel

The Thorlabs BC207UV(/M), BC207VIS(/M), BC210CU(/M) and BC210CV(/M) Camera Beam Profilers are equipped with a filter wheel containing six different neutral density (ND) optical attenuation filters. The filter wheel is designed to quickly and easily adapt the light source power to a power level within the dynamic range of the CMOS camera. Please make sure to stay below the saturation power of the camera.

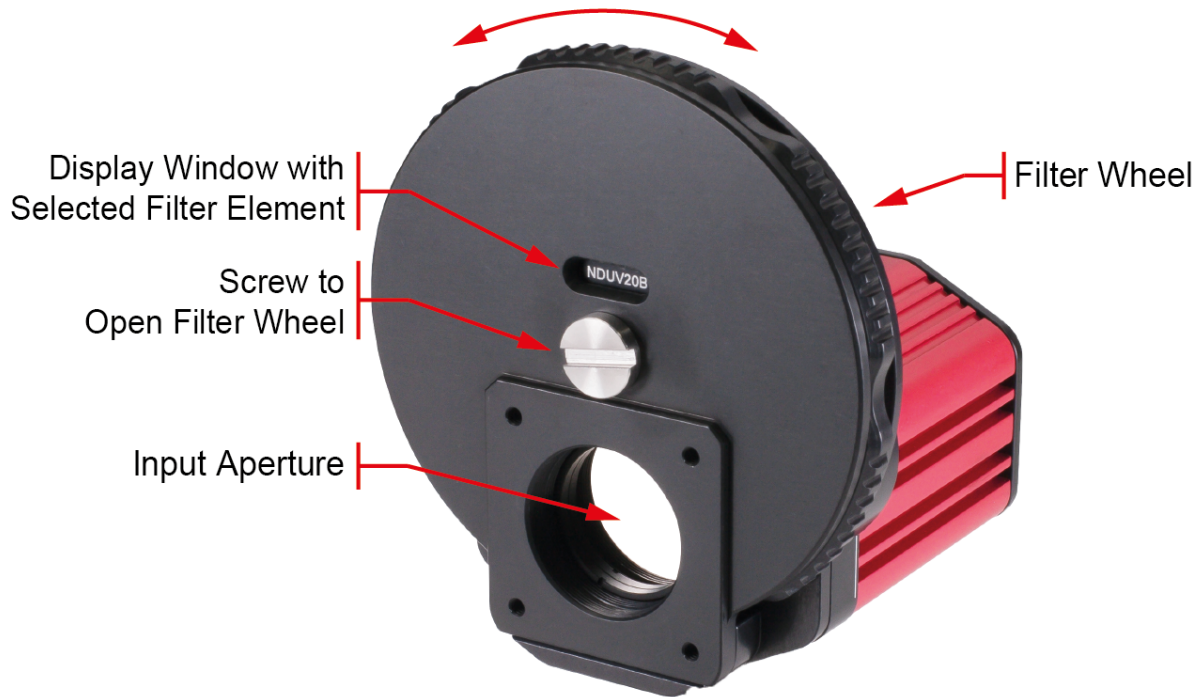

BC207 series

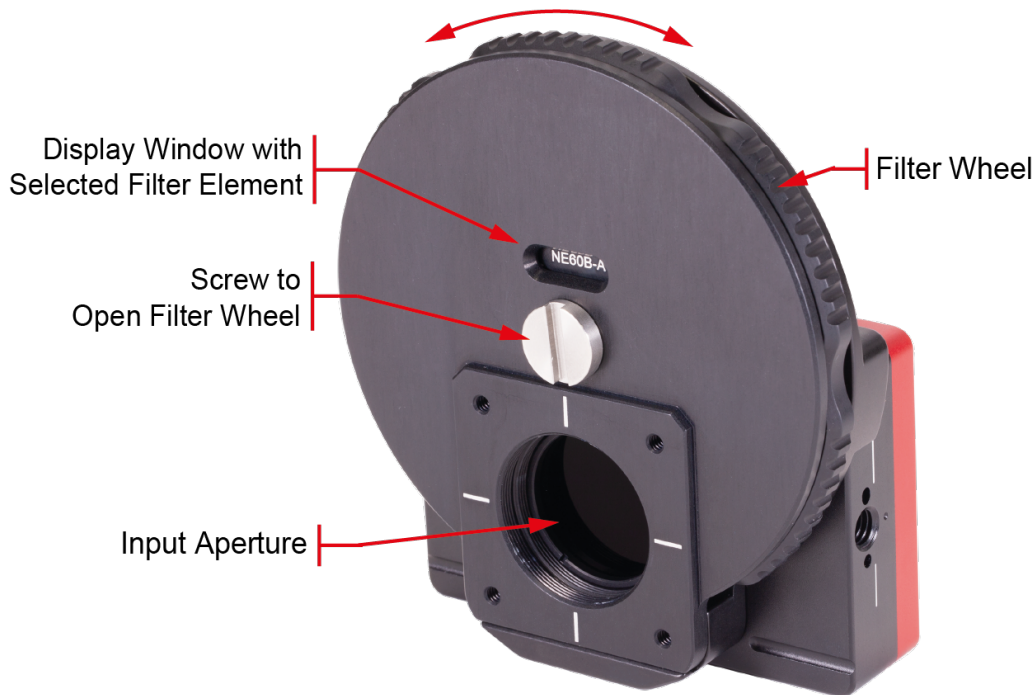

BC210C series

The filters come in a fixed configuration. A small window on the housing above the input aperture shows which filter is selected. The filter types and their nominal losses are model dependent as they are optimized for the wavelength of the BC207 and BC210C Series model. Please find information on the pre-configured filters and links to the respective website in the tables below.

Model BC207UV(/M) and BC210CU(/M) accommodates for a wavelength range between 245 - 400 nm. Please use the reflective filters NDUVxxB for applications between 245 nm and 350 nm with the BC207UV(/M) or BC210CU(/M). For applications above 350 nm, absorption filters can be used alternatively.

BC207UV(/M) and BC210CU(/M)	
Name on Filter Wheel	Filter Type
NDUV20B	20 dB UV Fused Silica Reflective ND Filter, 200 nm - 1200 nm
NDUV30B	30 dB UV Fused Silica Reflective ND Filter, 200 nm - 1200 nm
NDUV40B	40 dB UV Fused Silica Reflective ND Filter, 200 nm - 1200 nm
NE20B	20 dB UV Absorptive ND Filter, 400nm - 650 nm ¹
NE30B	30 dB UV Absorptive ND Filter, 400nm - 650 nm ¹
NE40B	40 dB UV Absorptive ND Filter, 400nm - 650 nm ¹

¹ These filters are provided for use near the 400 nm upper wavelength range of the BC207UV(/M) or BC210CU(/M).

The Model BC207VIS(/M) and BC210CV(/M) is equipped with six absorptive neutral density (ND) filters made from glass. One set of three comes with A-type anti-reflection coating (350 to 700 nm). The other set has a B-type AR coating for applications between 650 and 1050 nm.

BC207UV(/M) and BC210CU(/M)	
Name on Filter Wheel	Filter Type
NE20B-A	20 dB Absorptive ND Filter, AR-Coated: 350-700 nm
NE40B-A	40 dB Absorptive ND Filter, AR-Coated: 350-700 nm
NE60B-A	60 dB Absorptive ND Filter, AR-Coated: 350-700 nm
NE20B-B	20 dB Absorptive ND Filter, AR-Coated: 650-1050 nm
NE40B-B	40 dB Absorptive ND Filter, AR-Coated: 650-1050 nm
NE60B-B	60 dB Absorptive ND Filter, AR-Coated: 650-1050 nm

Attention

Be sure to have manually selected the appropriate ND filter corresponding to the actual operating wavelength! Beware of the reflected light from reflective UV filters!

Choosing the optimal attenuation

To adapt a light source with unknown power level to the Camera Beam Profiler it is highly recommended to use the automatic exposure control (see chapter [Camera Beam Profiler Parameters](#)⁴³) of the camera. In addition, it is advisable to start with the highest loss attenuation filter (40 or 60 dB) in order to prevent damage to the camera.

In case the Beam Software displays an error "Power too high, camera saturated!" the light intensity exceeds the maximum detectable power of the BC207 or BC210C Series Beam Profiler. In this case additional means for external beam attenuation in front of the beam profiler are required. The prism based Thorlabs [ATT30x](#) laser beam attenuators are particularly suitable as they preserve the polarization, size, and shape of the beam.

In case the Beam Profiler Software does not show a "Power too high" error it can be operated with this setting and the measurement results are reliable. However, in order to minimize beam distortions introduced by the ND filters, it is recommended to select the lowest possible attenuation.

Rotate the filter wheel in a 60 degree revolution to bring the nearest lower attenuation filter in front of the camera aperture. If a "Power too high" error appears, rotate the filter wheel back to the previous filter as this will be the optimal filter to use. If no error appears, rotate the wheel further until the lowest attenuation filter is in use.

When using a high loss attenuation filter in conjunction with a low power light source the software will display the warning "Power too low". This means the source is attenuated too much so that the camera's gain and exposure regulation is not able to achieve an evaluable signal level. In this case reduce the optical attenuation down to the lowest available filter loss (20 dB).

Alternatively, exchange or remove a filter from the filter wheel. To do so, unscrew the plate in front of the filters. Be very careful to avoid dust. Please be aware that when removing the filter, the label of the filter slot will not change. Please note which filter was removed.

The front plate can also be removed to clean the filters.

Attention

The BC207 and BC210C Series Beam Profiler must not be cleaned from dust using ethanol, cleaning tissue, cotton tipped applicators or any other mechanical tools! Using these chemical and/or mechanical tools voids warranty! Remove dust using only oil- and water-free compressed gas, such as Thorlabs Duster [CA4-US](#) or [CA6-EU](#) (Tetrafluoroetane). Keep the gas nozzle at least at a distance of 4 inches (10 cm) from the filter surface, otherwise liquid gas drops may hit the surface and leave visible traces on the filter surface; moreover the air pressure might damage the mirror.

Attention

For proper power measurement results, the currently chosen ND filter loss (in dB) must be entered into the Beam Profiler Software! See section [Device Settings](#)⁴³.

For correct beam profiling results it is highly recommended to shield ambient light from entering the Beam Profiler aperture. Using attenuation filters provided within the filter wheel will attenuate ambient light but will also absorb power of the light source by the same amount so that the ratio between both remains unchanged.

5.1.1.4 Change Filter Wheel

The Thorlabs BC207UV(/M), BC207VIS(/M), BC210CU(/M), and BC210CV(/M) Camera Beam Profilers are equipped with a filter wheel containing six different neutral density (ND) optical attenuation filters. In case of spatial constraints, the filter wheel can be removed.

When removing the filter wheel, please ensure a dust-free environment and recommended to wear rubber gloves. Even with gloves, avoid touching any optical surfaces. Please refer to the chapter [cleaning](#)¹⁶³.



1. Loosen the middle screw with a suitable tool. The screw does not need to be removed completely.



2. Remove the cover of the filter wheel. The screw can remain in the cover.



3. Completely loosen and remove the retaining ring of any ND filter using an [SPW602](#) Graduated SM1 Spanner Wrench.



4. Remove the ND filter. Please handle the filter carefully. Always wear gloves when handling filters, or touch the filter with a lint-free cloth.



5. Turn the filter wheel so that the grip recess is positioned above the first lower screw in order to remove the filter wheel completely with an Allen key, for example [BD-1/16](#).



6. Turn the filter wheel so that the grip recess is above the second lower screw in order to remove it completely with an Allen key (for example [BD-1/16](#)).



7. Turn the empty ND filter holder so that the first upper screw can be removed with an Allen key (for example [BD-1/16](#)).

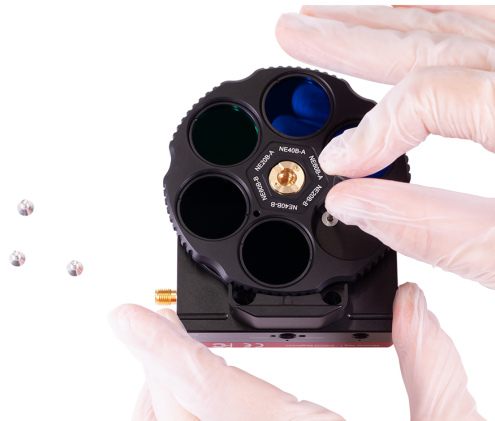

8. Afterwards, turn the empty ND filter holder so that the second upper screw can be removed with an Allen key (for example [BD-1/16](#)).



9. Now the filter wheel assembly can be removed from the camera housing. The camera's cover glass should not be touched.
10. To reattach the filter wheel, the steps must be performed in reverse order.

5.1.1.5 Status LED

With the Beam software installed and the Beam Profiler connected as instructed, the Status LED should light up solid Yellow, turning to solid Blue several seconds after power is applied. The table below details the conditions represented by the status indicator.

LED	If LED Is Flashing	If LED Is On	IF LED Is Off
Status	USB port cannot provide sufficient power to the camera	Blue: Connected to a USB 3.0 Port Green: Connected to a USB 2.0 Port Yellow: Camera has internal problem or computer USB port has malfunctioned	There is no USB Connection providing power to the camera

5.1.1.6 CMOS Sensor Protective Glass Window

The CMOS sensor is protected by a glass window. The type of window depends on the Series model:

Camera Beam Profiler	Window	Thickness
BC207UV(/M) or BC210CU(/M)	UV Fused Silica + UV AR coating	1 mm
BC207VIS(/M) or BC210CV(/M)	ND Filter NG3 1.0 OD	1 mm

5.1.1.7 Trigger Input

A TTL trigger input is provided for synchronizing the Camera Beam Profiler's global shutter with laser pulses. The appropriate BNC (for BC207 Series) or SMA (for BC210C Series) connector to connect to a trigger out of a laser driver is located on the back side of the instrument body, see the chapter Operating Elements [BC207UV\(/M\) and BC207VIS\(/M\)](#)^[6] or [BC210CU\(/M\) and BC210CV\(/M\)](#)^[8]. More Information on how to use the trigger input is described in the chapter [Trigger](#)^[45] in the software section of the manual.

5.1.1.8 Mounting BC207 Series

Post Mounting and Sensor Position

On the bottom side of the BC207 Series Camera Beam Profilers, a mounting thread is provided. All metric models have M6 x 1 mm threads while the imperial models feature a 1/4"-20 thread.



Mount the BC207UV(/M) or BC207VIS(/M) Camera Beam Profiler to your optical system using a Thorlabs [post](#), [post holder](#) and a [base or clamping fork](#).

Sensor Position on BC207UV(/M) and BC207VIS(/M)

The sensor is centered with respect to the mounting thread holes on the bottom of the device. Its depth measured from the front surface of the filter wheel is 20.7 mm (0.82 ").

This is also indicated by a fine white line engraved in the housing. This line is labeled "Optical Measurement Plane" in the [drawings](#)^[155].

Please see the dimensions of [BC207UV\(/M\)](#)^[155] and [BC207VIS\(/M\)](#)^[155] for the precise position of the sensor on the camera beam profilers.

5.1.1.9 Mounting BC210C Series

Post Mounting and Sensor Position

On the bottom and left side of the BC210C Series Camera Beam Profilers, a mounting thread is provided. All metric models have M6 x 1 mm threads while the imperial models feature a 1/4"-20 thread.

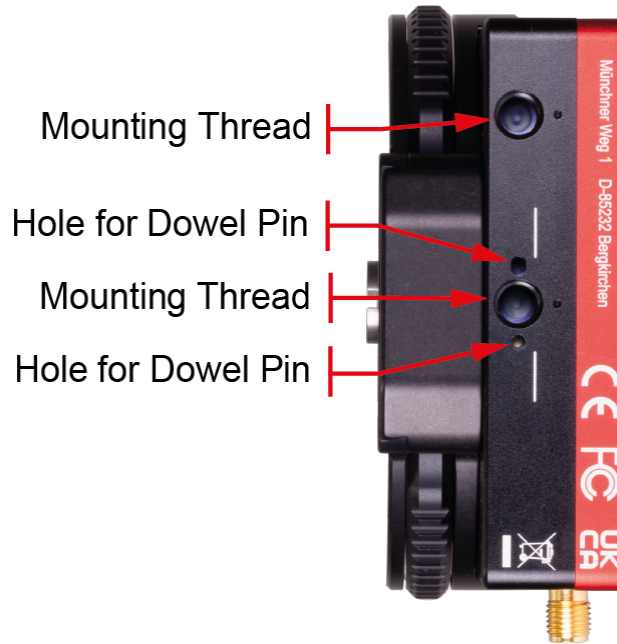

BC210C bottom view

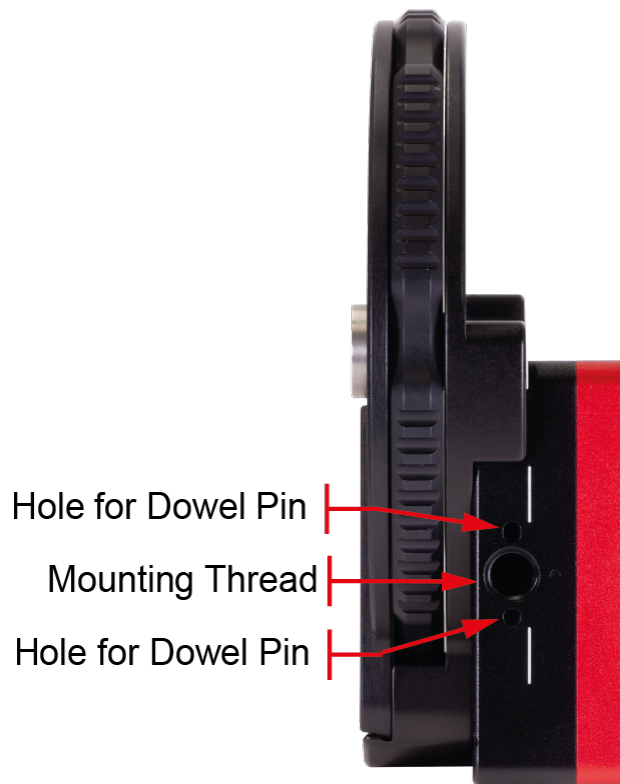

BC210C side view

Mount the BC210CU(/M) or BC210CV(/M) Camera Beam Profiler to your optical system using a Thorlabs [post, post holder](#) and a [base or clamping fork](#).

Sensor Position on BC210CU(/M) and BC210CV(/M)

The sensor is centered with respect to the mounting thread holes on the bottom of the device. Its depth measured from the front surface of the filter wheel is 20.3 mm (0.80 ").

This is also indicated by a fine white line engraved in the housing. This line is labeled "Optical Measurement Plane" in the [drawings](#) ¹⁵⁶.

Please see the dimensions of [BC210CU\(/M\) and BC210CV\(/M\)](#) ¹⁵⁶ for the precise position of the sensor on the camera beam profilers.

5.1.2 Camera Beam Profiler Series with M2MS Extension Set

5.1.2.1 Operating Elements M2MS

The components of M2MS M² Measurement System are labeled in the image below. These components are identical to M2MS-AL.

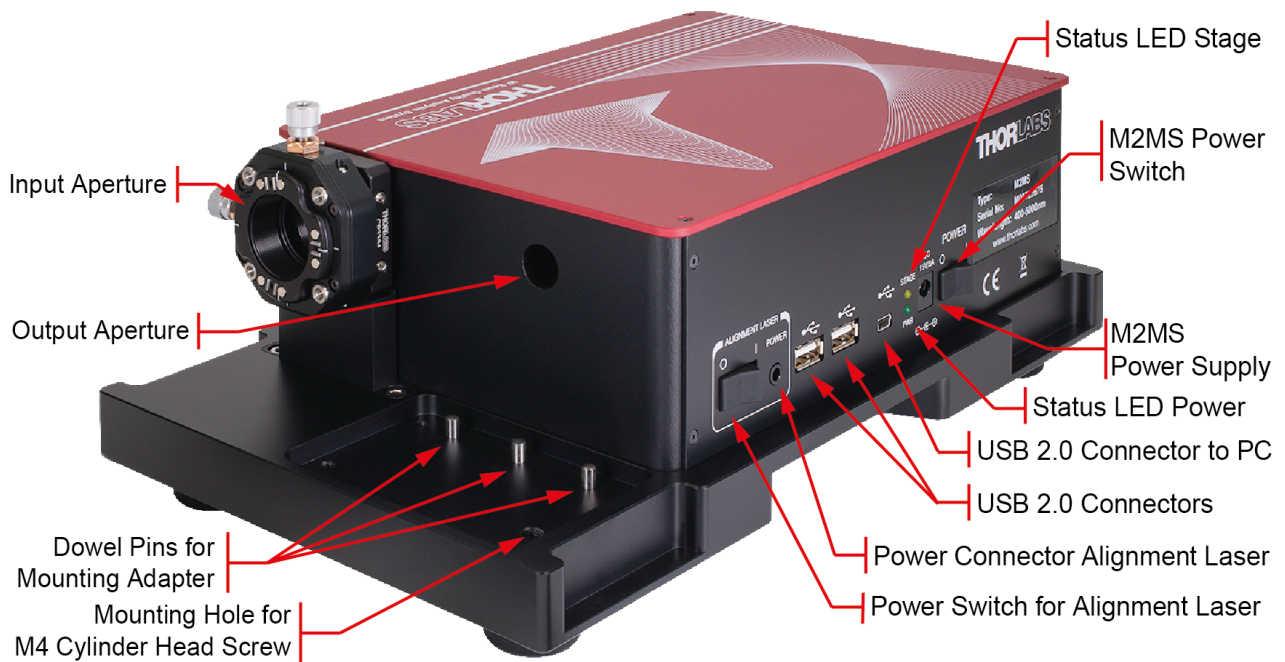

5.1.2.2 Mounting BC207 Series on M2MS(-AL)

Please use the mounting adapter for BC207 Series to M2MS in order to mount the BC207UV(/M) or BC207VIS(/M) beam profiler to the M2MS Measurement Extension. For a mounting adapter for BC207 onto a preexisting M2MS Extension Set, please contact [Thorlabs](http://Thorlabs.com).

1. Place the BC207 Series device onto the mounting adapter for the BC207 Series such that the dowel pins on the adapter fit into the holes for the dowel pins on the BC207 Series device.



Bottom View BC207 Series

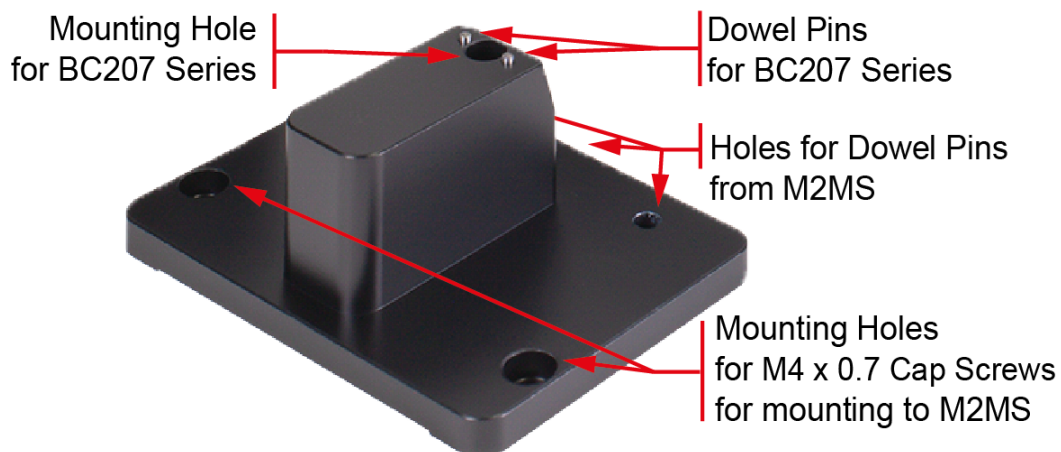

M2MS Adapter for BC207UV(/M) and BC207VIS(/M)

2. Hold the BC207 Series device to the mounting adapter and turn both together upside down. Insert the 25mm long M6 x 1 cap screw, or 1" long 1/4"-20 cap screw into the mounting hole on the bottom of the mounting adapter and secure the BC207 Series device on the adapter.
3. Place the adapter with the BC207 Series onto the M2MS Measurement Extension such that the three $\varnothing 4$ mm dowel pins protruding from the M2MS Measurement Extension will fit into the respective holes in the mounting adapter. With that, the input aperture of the BC207 Series faces the output aperture of the M2MS.

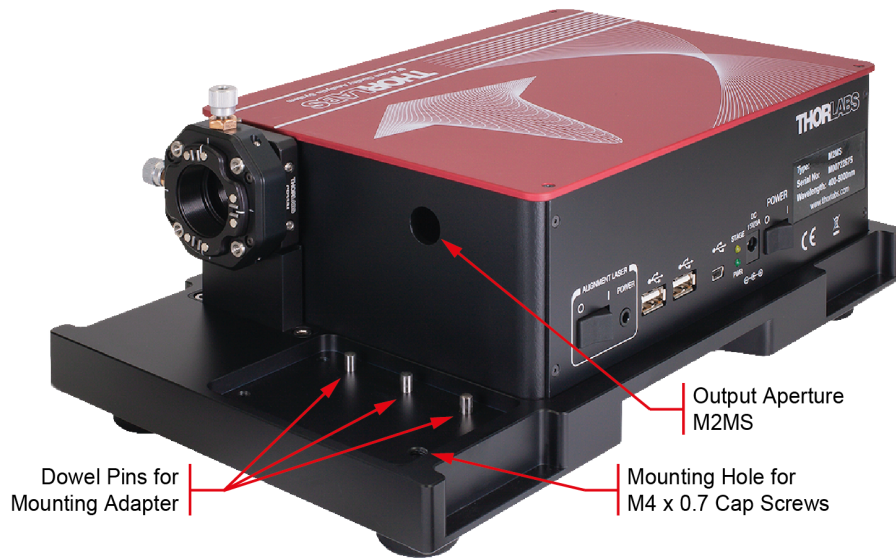

- Secure the adapter with the two enclosed M4 x 0.7 Cap Screw onto the M2MS Measurement Extension.

The BC207UV(/M) or BC207VIS(/M) is now securely mounted to the M2MS Measurement Extension.

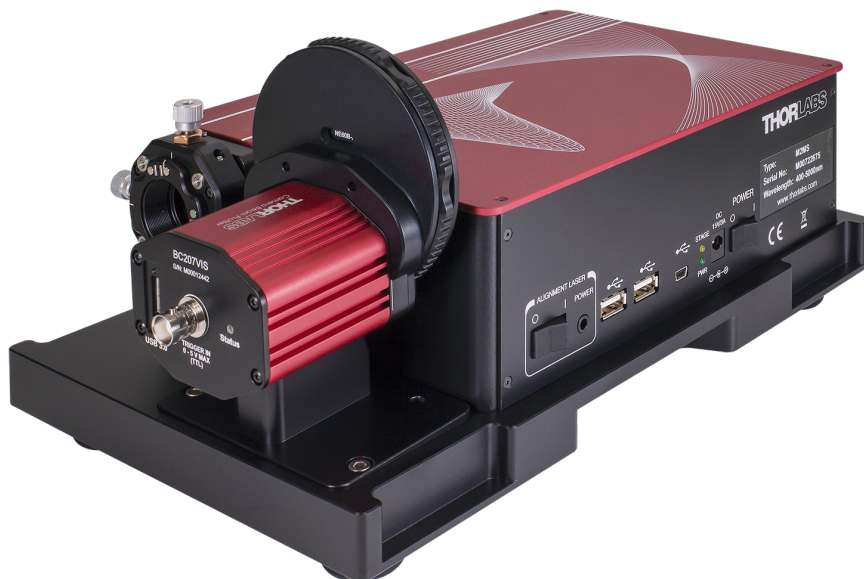

5.1.2.3 Mounting BC210C Series on M2MS(-AL)

Please use the mounting adapter for BC210C Series to M2MS in order to mount the BC210CU(/M) or BC210CV(/M) beam profiler to the M2MS Measurement Extension. For a mounting adapter for BC210C onto a preexisting M2MS Extension Set, please contact [Thorlabs](http://Thorlabs.com).

1. Place the BC210C Series device onto the mounting adapter for the BC210C Series such that the dowel pins on the adapter fit into the holes for the dowel pins on the BC210C Series device.

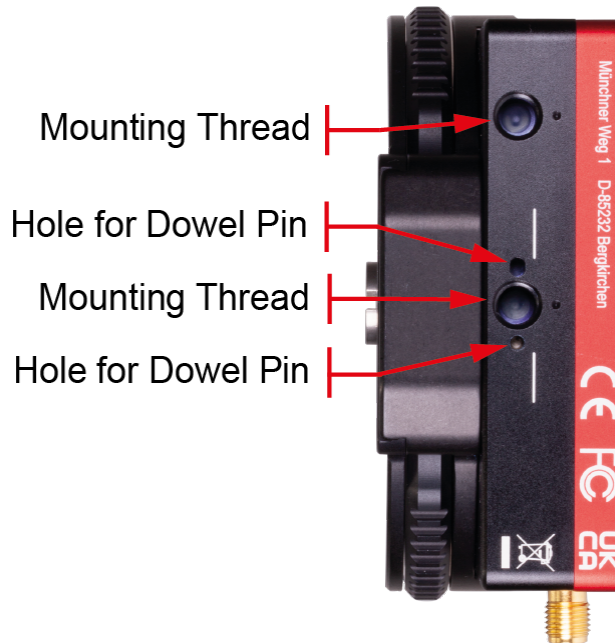

BC210C bottom view

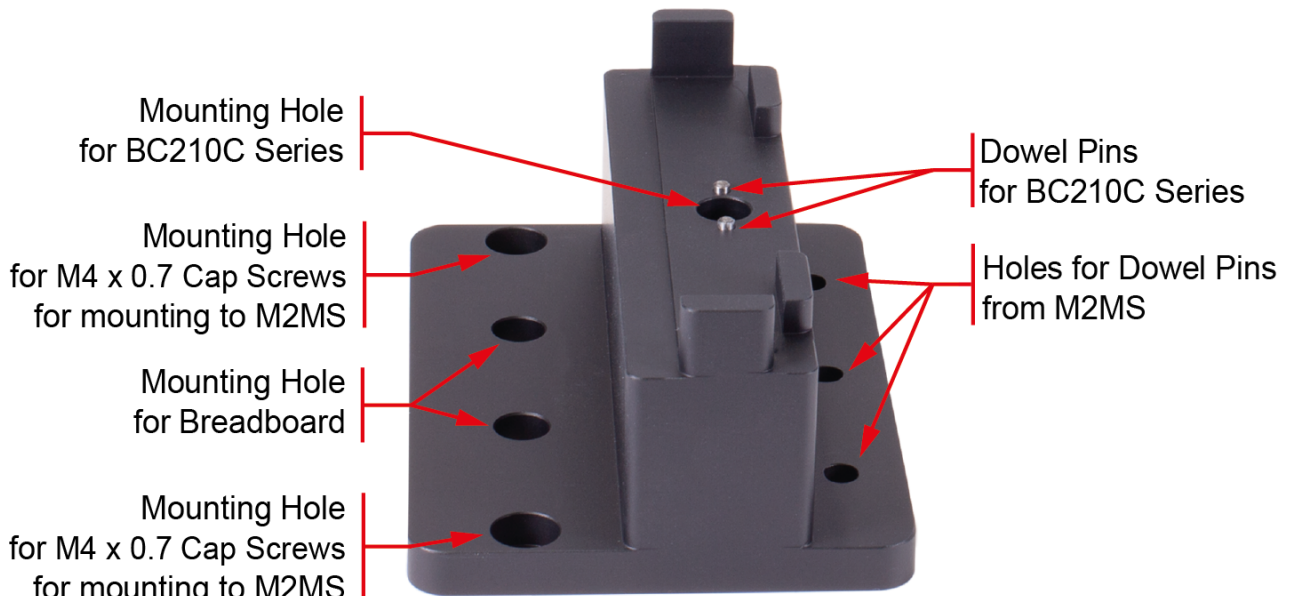

M2MS Adapter for BC210C series

2. Hold the BC210C Series device to the mounting adapter and turn both together upside down. Insert the 25mm long M6 x 1 cap screw, or 1" long 1/4"-20 cap screw into the mounting on the bottom of the mounting adapter and secure the BC210 Series device on the adapter.

- Place the adapter with the BC210C Series onto the M2MS Measurement Extension such that the three Ø4 mm dowel pins protruding from the M2MS Measurement Extension will fit into the respective holes in the mounting adapter. With that, the input aperture of the BC210C Series faces the output aperture of the M2MS.

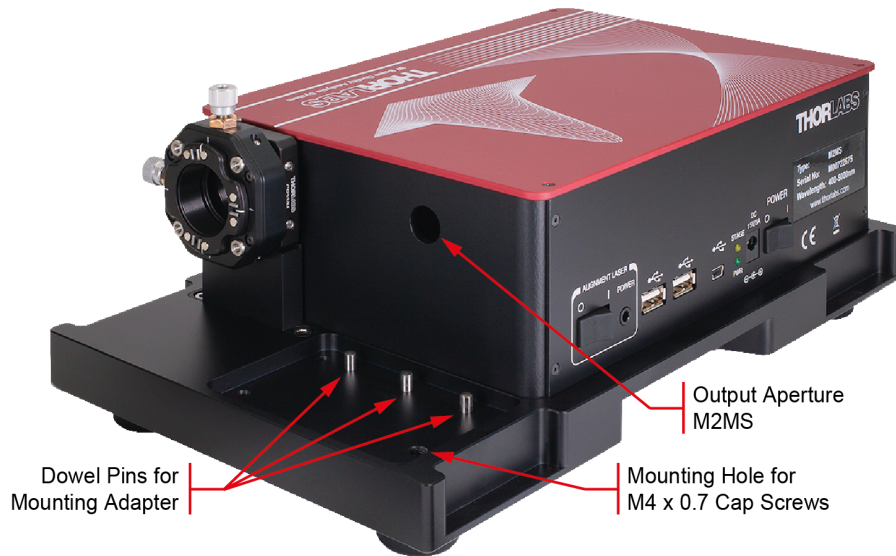

- Secure the adapter with the two enclosed M4 x 0.7 Cap Screw onto the M2MS Measurement Extension.

The BC210CU(/M) or BC210CV(/M) is now securely mounted to the M2MS Measurement Extension.



5.2 Setup BC207 and BC210C Series

This chapter describes the setup for the BC207UV(/M), BC207VIS(/M), BC210CU(/M) and BC210CV(/M).

1. Provide stable mounting of the Beam Profiler as described in the chapter [Mounting BC207 Series](#) or [Mounting BC210C Series](#).
2. Download the Beam Software version 8.0 or higher through the software tab on the BC207 Series [website](#) and [install](#) it on your computer (Download the Beam Software version 9.0 or higher through the software tab on the BC210C Series [website](#) and [install](#) it on your computer).
3. Connect the camera using the supplied USB 3.0 cable to the PC as described in [Connection to the PC](#).
4. [Start](#) the Beam Software.
5. With the dust cap still on the beam profiler, adjust the BC207 or BC210C Series Camera Beam Profiler such that its optical aperture will be exposed to the optical beam.
6. Be sure to operate the instrument within its specified [Power Range](#). Please regard the output power of your light source.
 - a. Choose a neutral density (ND) filter in the [Filter wheel](#) which is suited for the operating **wavelength** (UV / VIS) of your light source.
 - b. Select a filter attenuation which is adapted to the applied laser power. Always start with the **maximum attenuation** to prevent damage to the beam profiler.
 - c. If required, choose additional attenuation in front of the beam profiler to stay within the specified power range.
7. Remove the dust cap.
8. Minimize ambient light entering the Beam Profiler aperture.
9. Switch on the light source.
10. Align the beam to be measured so that it is perpendicular to the front face of the Beam Profiler.

Attention

Do not stick anything into the Beam Profiler aperture! The protective glass might be scratched.

Prevent dust or other contamination from entering the aperture!

Keep beam power below the allowed limit to avoid damage to the instrument!

5.3 Installation

5.3.1 Software Installation

The Beam Software can be downloaded from the Thorlabs website:

http://www.thorlabs.com/software_pages/ViewSoftwarePage.cfm?Code=Beam

Please check for updates to the Thorlabs Beam Software and always use the latest Software version.

The Beam software versions 9.0 or higher support the BC210C beam profiler series. Software versions below version 9.0 do not support the BC210C Series.

The Beam software versions 8.0 or higher support the BC207, BP209, and BC106N beam profiler series. Software versions below V8.0 do not support the BC207 Series.

- Save the ZIP file to your computer and unpack the archive. The Install Shield Wizards starts by double-clicking the setup.exe.
- The installation contains 2 main parts - the NI-VISA™ Runtime V17.0 (for Windows® 8.1 and Windows® 10) or the NI-VISA™ Runtime V2022 Q3 (for Windows® 11) and the Beam Software itself, including drivers and the manual.
- Please read the license agreements carefully, choose "I agree" and click 'Next'.

- Windows Security will ask your confirmation to install the Thorlabs USB driver.
- You may check the box "Always trust software from "Thorlabs GmbH". This will shorten the installation. However, if you do not want to do that, please click the "Install" button. You will then be asked to confirm the installation of further Thorlabs software components. Please install the instrument driver packages as well as the Firmware Loader Driver Package.
- When all drivers are installed, the "Read Me" comes up.
- Click "Next", then "Finish" to complete the software installation.

5.3.2 Connection to the PC

Connect the BC207 or BC210C Series Beam Profiler to a USB 3.0 port of your computer. Use only the cable that comes with the beam profiler or a cable qualified for high speed USB 3.0 standard.

Attention

Use only the supplied USB 3.0 cable. USB 2.0 or USB 1.1 cables can cause transmission errors and improper instrument operation!

Please make sure, that the USB cable is connected to a USB 3.0 port.

After connecting the instrument to the PC, the operating system loads the appropriate USB drivers for the Beam Profiler instrument.

Once connected, an icon will appear in the task bar indicating that the driver installation is in progress

To verify the correct driver installation, check the presence of the instrument in the Device Manager: From the Start button select Control Panel to Device Manager.

If you cannot see an entry please check the [troubleshooting](#) ¹⁶⁴ section.

5.3.3 Start the Application

Click the "Programs" → "Thorlabs" → "Thorlabs Beam Application" entry, or simply click the appropriate icon added to your desktop.

When the application is started, the following start screen appears:

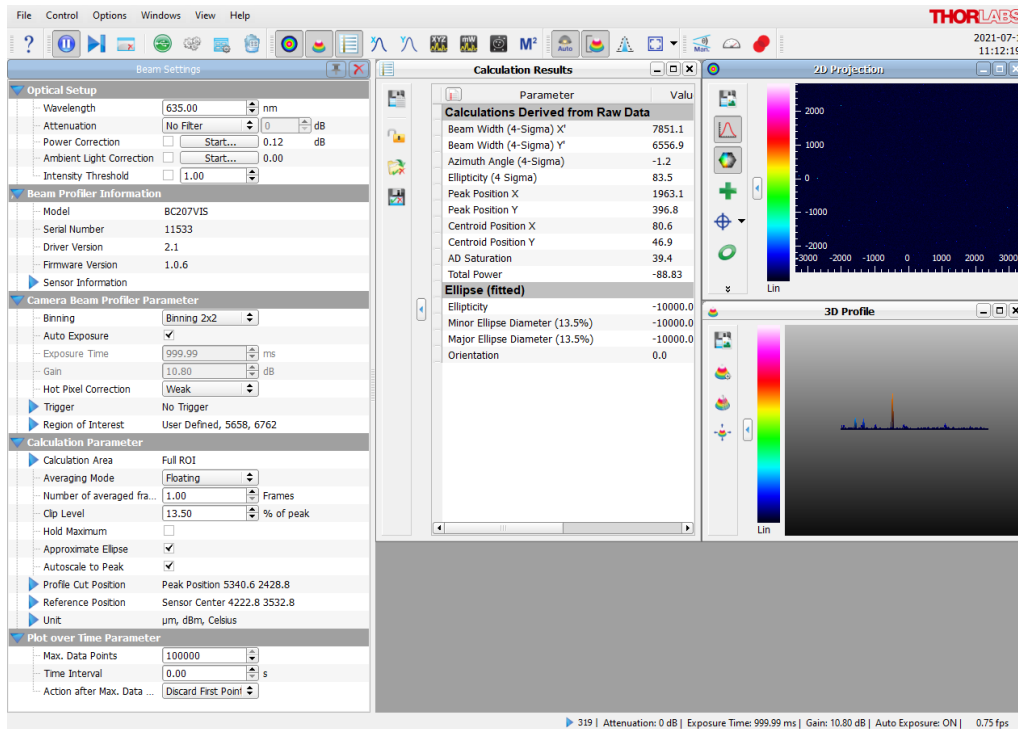

The connected camera instrument parameter is recognized, automatically connected and shown in the Beam Settings panel:

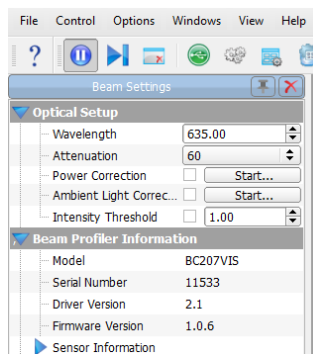

Usually the Beam Software connects automatically to the instrument that has been connected first. If you have connected more than one Beam Profiler and want to use another than the connected device, select to the icon "Device Connection"  and click the desired instrument:

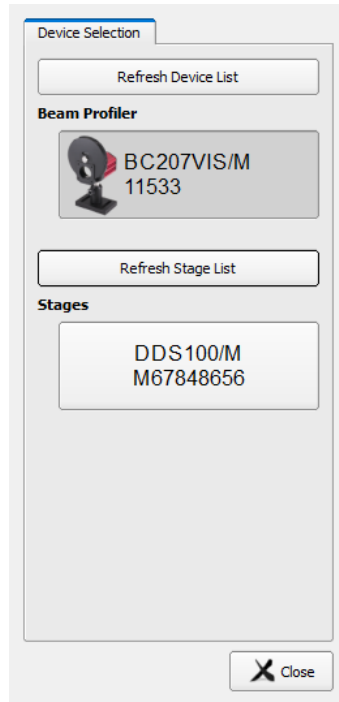

Click on 'Refresh Device List' for an update if you have very recently connected or removed a Beam Profiler instrument from your PC. If an expected instrument is still missing check if the USB driver is properly installed (see chapter [Troubleshooting](#)¹⁶⁴).

After selecting a Beam Profiler it will be connected and displayed in the [Beam Settings Panel](#)³⁶, where all available settings and adjustments to the Beam Profiler can be made.

It is advisable to read the steps described in the chapter [Measurement with the Beam Profiler](#)⁸³ carefully in order to setup your Beam Profiler device and application properly.

When the Beam Profiler Software is started for the first time, three preselected windows are opened and arranged automatically: Calculation Results, 2D Projection, 3D Profile. Otherwise, the arrangement of the last session (selected windows and their position) will be recovered. See the [Child Windows](#)⁵⁷ chapter for a detailed description of each window.

5.4 The Graphics User Interface (GUI)

In this manual, the Beam Software is described based on a setup using a BC207VIS on the M2MS measurement extension for M^2 measurements, connected to a PC running with OS Windows® 10. The application automatically adapts to the specifications of the BC207 or BC210C series beam profiler.

The main window consists of a menu bar (1), a tool bar (2), a status bar (3) and common frame for displaying several child windows. When starting the application, an additional window is displayed within the main window - the [Beam Settings](#) (4) panel. This panel can be unpinned from the main window and moved to a different display location, e.g., to a second monitor.

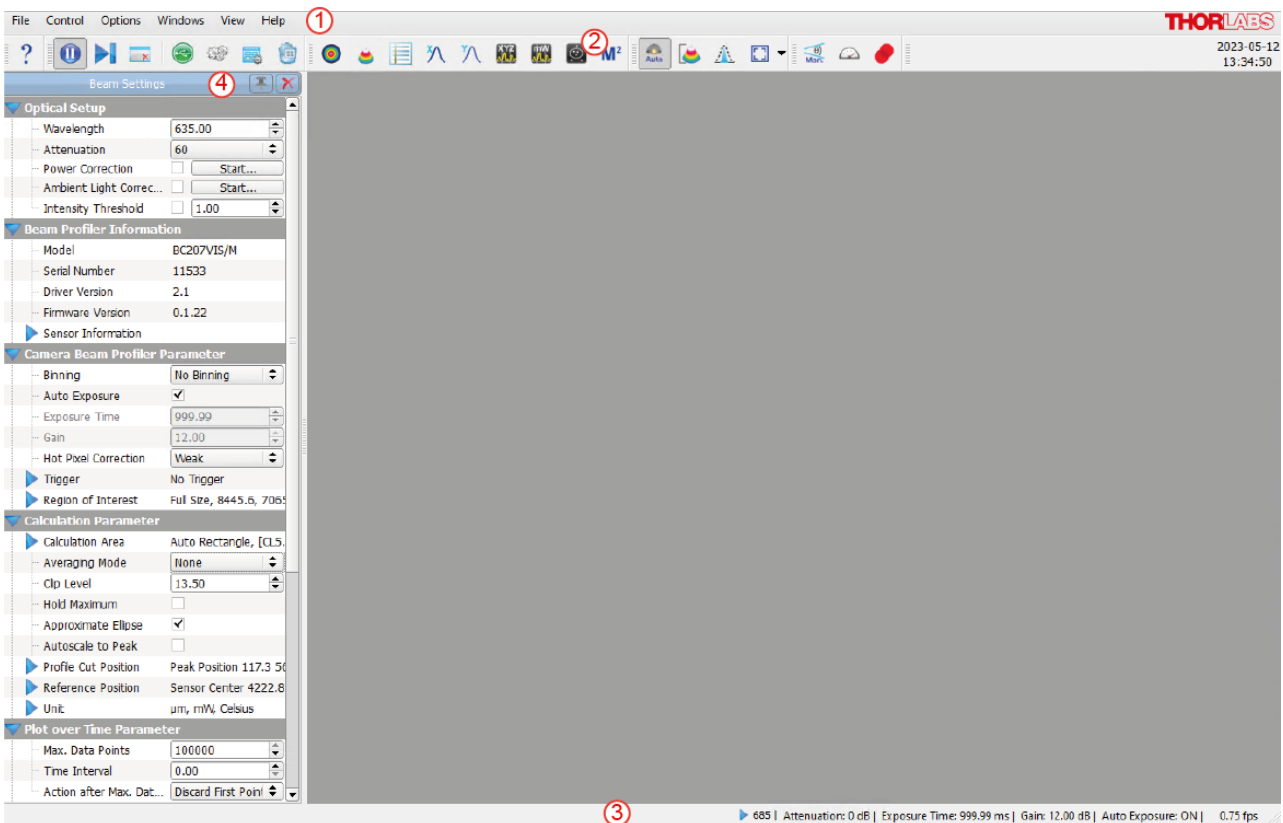

5.4.1 Menu Bar

All user activities can be done using the menu bar items

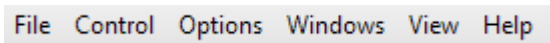

5.4.1.1 File Menu

These menu entries deal with files or printing.

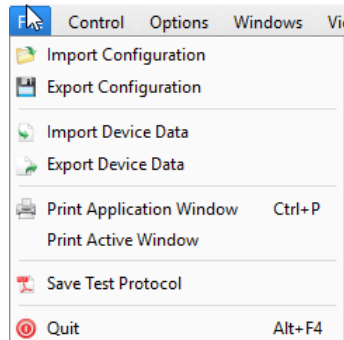

The entries in the first block, **Import** and **Export Configuration**, are related to XML files which contain information about the chosen Beam Profiler device and its settings, file export parameters and application settings. In order to copy the GUI appearance and Beam Profiler settings to another PC you need to save the configuration file, copy it and load it on the target system.

The second part allows to import and export data originally retrieved from the Beam Profiler:

Export

- RAW format: This is a product specific bitmap with additional information, here pixel pitch (distance between 2 pixels) and exposure time.
- BMP format: This is the standard, uncompressed bitmap image retrieved from the camera.
- Intensity Value Text Matrix: This matrix saves 12bit values. The 1st value in the 1st line represents the intensity of the left upper pixel in the 2D projection.
- TIFF (8bit), PNG and JPG formats: Standard picture formats for easy integrating of measurement results into external documents.
- A sequential saving is available as well. Details please see section [Calculation Results](#)⁶⁷.

Import

The import is limited to Device Data allowing reconstruction of the original measurement result with the Beam Software.

- RAW format: Along with the bitmap, saved from the camera, pixel pitch and exposure time are used for calculation, so the imported beam profile will reproduce the true size and also the optical power.
- BMP format: Only the bitmap will be shown. The dimensions in X and Y direction are not the original ones (pixel pitch will be considered as 1).

Print

With the **Print Application Window** a screenshot of the Beam Profiler application is printed.



The **Print Active Window** entry prints the current active child window of the Beam Profiler application. This function gives you the opportunity to print a specific child window.

The **Save Test Protocol** opens a dialog window, where individual data can be entered. Click "Save" and then "Close" to save a test report with the calculation results and the current projection image to the indicated location. If the 3D Profile window is opened, a screenshot of the 3D Profile is also included in the test report.

See some detailed examples for data export in the [Save Measurement Results](#)⁶⁷ chapter.

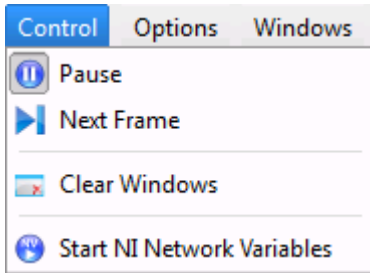
5.4.1.2 Control Menu



Use the first menu entry to start  and pause  the continuous operation of the Beam Profiler device including retrieving measurement data, performing calculations and displaying graphs and numerical results to the output windows.

"Next Frame" starts a single measurement and returns to pause state.

When the GUI is started or the active Beam Profiler instrument is changed, the application will start continuous operation automatically.

Pausing the consecutive operation is advantageous for detailed analysis of a single image. The paused Beam Profiler can be restarted at any time.

The "**Clear Windows**" function resets the content of all windows, including child windows. The window content will be filled with the next measurement result received from the instrument. This function may be useful in combination with a trigger mode while waiting for the next image or for a synchronous restart of all plots and time-based measurements.

Note

The measurement of all beam parameters and the accumulation of calculated data is started automatically with the software start. "Clear Windows"  deletes all accumulated data and restarts the measurement.

Start NI Network Variables

This feature is a data interface for handing over the parameters listed below to an external program environment such as LabVIEW.

- Saturation (in %)
- Total Power
- Base Line X and Y
- Peak Value X and Y
- Distance of Peak to Reference Position X and Y
- Distance of Centroid to Reference Position X and Y
- Sigma X and Y
- Beam Width Clip X and Y
- Ellipse Diameter Min and Max
- Gauss Diameter X and Y
- Ellipticity
- Camera Temperature
- Pixel Pitch
- User Power Offset
- Serial Number
- Reference Position X and Y

Note

In order to use this command, you need to have installed additional National Instruments® software (Distributed System Manager, NI CVI Runtime Engine).

5.4.1.3 Options Menu

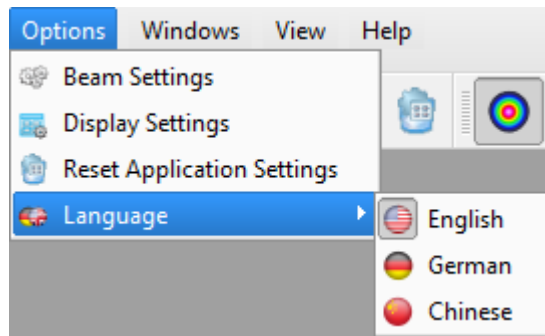

These entries allow changing the device (Beam Profiler) and application (GUI) specific settings and let you choose a language.

Beam Settings

The Beam Settings panel contains all important information about the optical settings, the properties of the active Beam Profiler and a summary of the calculated beam parameters. Please see the detailed description of this panel in the section [Beam Settings](#)³⁶.

Display Settings Panel

Here, the different styles for **2D Projection** and **3D Profile** are listed for selection.

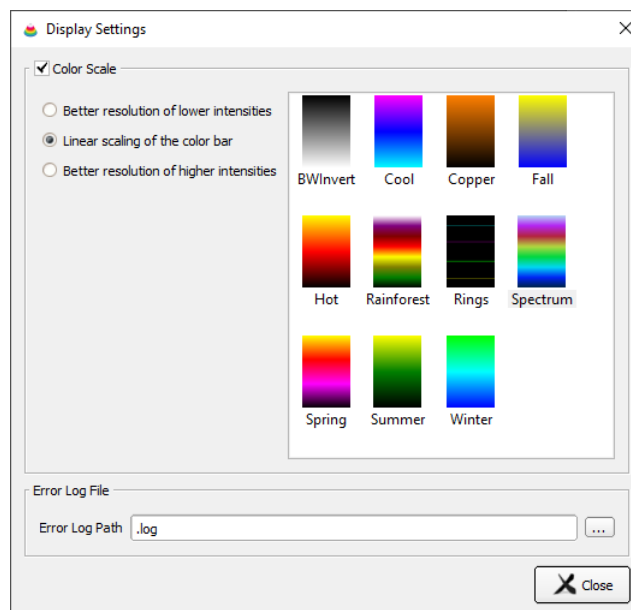

There are 3 different color scale types available:

- Better resolution of lower intensities (Logarithmic Scale))
- Linear scaling of the color bar (Linear Scale)
- Better resolution of higher intensities (Quad Scale)

User-Configured Color Scales

If a certain color scale is required it is possible to create a custom color scale which can be loaded automatically by starting the application. To do so a few things need to be considered.

When starting the software, the application loads valid *.lut files from the folder:

...\My Documents\Thorlabs\Thorlabs Beam\LUT

A valid *.lut file must fulfill the following criteria:

- Ordinary text file with 9 columns and 256 rows
- Values must be tab-separated
- The first three columns have 256 entries
- The last six columns have only 129
- Each value represents a 8 bit intensity (0- 255) of R(ed), G(reen) and B(lue), respectively.

The first three columns represent the linear scale of a user-made color scale, the next three columns represent the scale for lower intensities (logarithmic scale) and the last three columns the scale for higher intensities (quad scale).

Such a color scale could look like this (The first two rows are not part of the *.lut file; they are shown here only for illustration):

Linear Scale			Logarithmic Scale			Quad Scale		
R	G	B	R	G	B	R	G	B
0	255	0	0	255	0	0	255	0
1	255	0	1	255	0	3	255	0
2	255	0	2	255	0	10	255	0
...
127	255	0	240	255	0	254	255	0
128	255	0	255	255	0	255	255	0
129	255	0						
...						
254	255	0						
255	255	0						

"..." stands for the intermediary values.

 **Reset Application Settings to Defaults**

This button resets all BEAM application settings to defaults:

Application Setting	Default Value	Explanation
Intensity Threshold	Disabled	
Auto Exposure	Enabled	Exposure time set to automatic
Trigger Mode	No Trigger	Instrument set to continuous data acquisition
Region of Interest	Full Size	ROI is set to full sensor size.
Calculation Area Preset	Auto Rectangle	Software determines a rectangular area in which the power level is above the clip level.
Calculation Area Clip Level	1.0 %	For defining the Calculation Area in automatic mode, the lower intensities limit is set to 1% of the peak intensity to clip noise.
Averaging Mode	None	No averaging
Clip Level	13.50 %	The clip level for calculating the ellipse and beam width is set to 13.5% of the difference between the baseline and the peak intensity.
Measurement Method	All Pixels	All pixels are used for calculation, no slit emulation.
Hold Maximum	Disabled	
Approximate Ellipse	Enabled	The ellipse is approximated to get a smooth surrounding.
Autoscale to Peak	Enabled	The diagrams that show intensities, are scaled to the peak intensity.
Profile Cut Position	Peak Position	The X and Y profiles are taken from the row and column where the peak is located.
Reference Position	Sensor Center	Reference position is set to the sensor center. Centroid and peak positions are calculated relative to the reference position.
Position Unit	μm	All position units are displayed in μm .
Power Unit	mW	All power units are displayed in mW.
Plot Method	Latest Data	After reaching the max. number of data to be plotted, with the next data acquisition the first data set will be discarded and the the most recent set will be added.
Plot Interval	Every Meas.	For every measurement, the data are plotted
Max. Data Points	100000	The maximum number of data to be plotted
Velocity	200 mm/s	Translation speed of the stage
Hot Pixel Correction	Weak	see chapter Hot Pixel Correction ⁴⁵

Language 

The language of the application can be selected.

5.4.1.4 Windows Menu

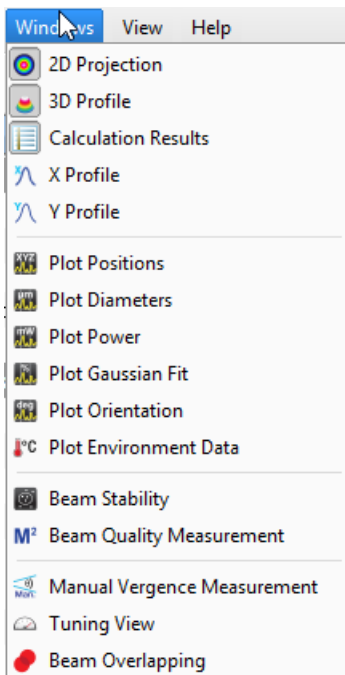

When the GUI is started the first time, the Default Workspace is opened. To close and open the windows, toggle the corresponding entry in the windows menu or via the [Tool Bar](#) .

An open child window can also be closed by clicking the  in the upper right corner of the child window.

5.4.1.5 View Menu

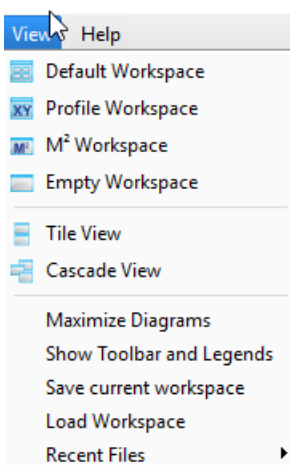

From this menu entry, a number of pre-configured child window arrangements ("workspaces") can be quickly selected:

- Default: Settings panel, Numeric results, 2D projection, 3D profile
- Profile: 2D projection, 3D profile, numeric results, X and Y profiles
- M²: Beam Quality Measurement, X and Y profiles
- Empty workspace

Further, the active child windows can be arranged, tiled, and cascaded.

"Maximize Diagrams" turns off the side and top toolbars in all child windows simultaneously, **"Show Toolbar and Legends"** turns them on again.

"Save Current / Load Workspace" saves your Beam Software GUI appearance to a ini-file that can be loaded at any time.

"Recent Files" lists recently used workspace files so that you can quickly load often used workspaces.

5.4.1.6 Help Menu

Click "Contents", the first entry within the help menu, or press the "F1" key on the keyboard to open the online help file, which contains all information included in this manual.

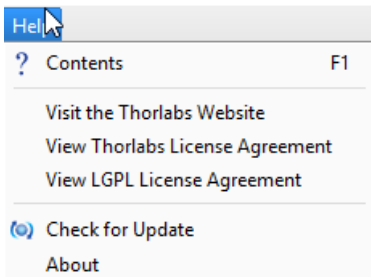

With a click on the link *Visit the Thorlabs Website* this website is opened in the browser window.

View Thorlabs (LPGL) License Agreement will open the license files of the installer package.

Check for Update searches for available software updates.

About Thorlabs displays device information and software versions details:

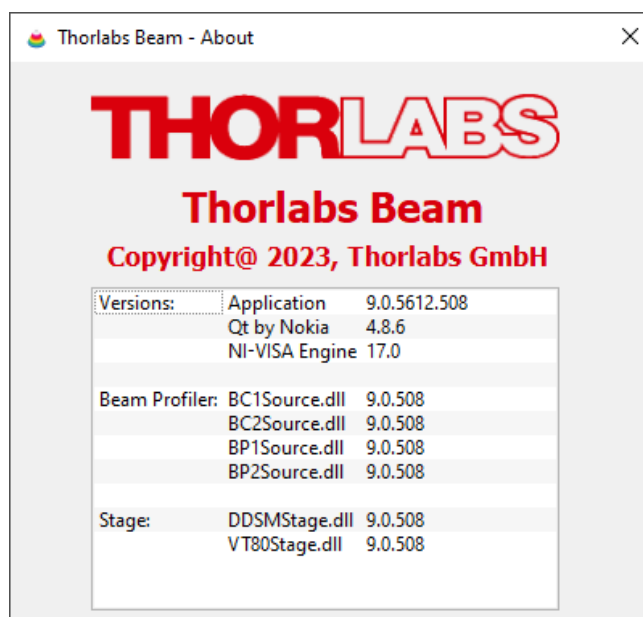

If you have trouble with the software, please submit the version of the application to Thorlabs. This can help to resolve your problem.





5.4.2 Tool Bar





















For the most important menu entries there are also symbols provided in the tool bar.





Clicking on a toolbar symbol will have the same effect as clicking on the original menu entry. When moving the mouse over the icons, a tool tip will be displayed.

In the list below the toolbar icons are explained.

-  Open the online help file
-  [Pause and start the continuous device operation](#) ²⁹
-  [Take a single measurement](#) ²⁹
-  [Clear the content of each window](#) ²⁹

-  Open the Device Connection dialog
-  Restore [Beam Settings](#) ^[36] panel (if unpinned or closed)
-  Open the [Display Settings](#) ^[30] panel
-  [Reset application settings to defaults](#) ^[32]
-  Open child window [2D Projection](#) ^[58]
-  Open child window [3D Profile](#) ^[61]
-  Open child window [Calculation Results](#) ^[64]
-  Open child window [X Profile](#) ^[62]
-  Open child window [Y Profile](#) ^[62]
-  Open child window [Plot Position](#) ^[75]
-  Open child window [Plot Power](#) ^[76]
-  Open child window [Beam Stability](#) ^[81]
-  Open child window [Beam Quality \(M²\)](#) ^[100]
-  Toggle [auto exposure on/off](#) ^[44]
-  Toggle auto scale to peak on/off
-  Toggle max hold on/off
-  Change [ROI \(drop down\)](#) ^[49]
-  Open child window [Manual Vergence Measurement](#) ^[68]
-  Open child window [Tuning View](#) ^[70]
-  Open child window [Beam Overlapping](#) ^[72]

5.4.3 Status Bar

 Power too low!  3558 | Attenuation: 0 dB | Exposure Time: 28.00 ms | Gain: 0.00 dB | Auto Exposure: OFF | 0.00 fps

The status bar displays important status information about the Camera Beam Profiler concerning

- Errors and warnings, see chapter [Warnings and Errors](#)^[165].
- Plot Data Point Status, see section [Plots](#)^[74].
- Attenuation setting (by [Filter Wheel](#)^[9] or external attenuator).
- Camera settings like Exposure Time and Gain.
- Current refresh rate of the application in frames per seconds (fps).
- Alternatively, if stored Device Data are loaded, the location of the file is displayed.

5.4.4 Save Settings





The actual settings of the GUI including configurations of the graphical displays and the instrument setup are automatically saved when exiting the program. When starting the Beam Software again, the most recent settings are automatically loaded.

Exception: Actual zoom settings of 3D graphs, the rotation and translations are not stored. This is to see the full aperture range and full amplitude range on every start of the GUI.

Note

The stop state of the previous measurement will be ignored at a new start of the Beam Software because it always starts in continuous mode.

5.4.5 Beam Settings

The **Beam Settings** panel is a very convenient visualization of all important information and settings that can be made to the instrument and to the calculation parameters. For a better visibility, the Beam Settings topics are arranged in expandable group boxes that allow to show or hide topics. Further, the Beam Settings panel is the only child window that can be detached: When starting the application, this panel arranged by default within the main window. Drag and drop it to any convenient location within or outside the GUI main window, e.g., to a second PC monitor. When detached, the **Pin** icon in the upper right corner changes from  to . Click to this icon to bring the panel back into the GUI frame. The panel view can be customized easily by expanding  or hiding  topics.

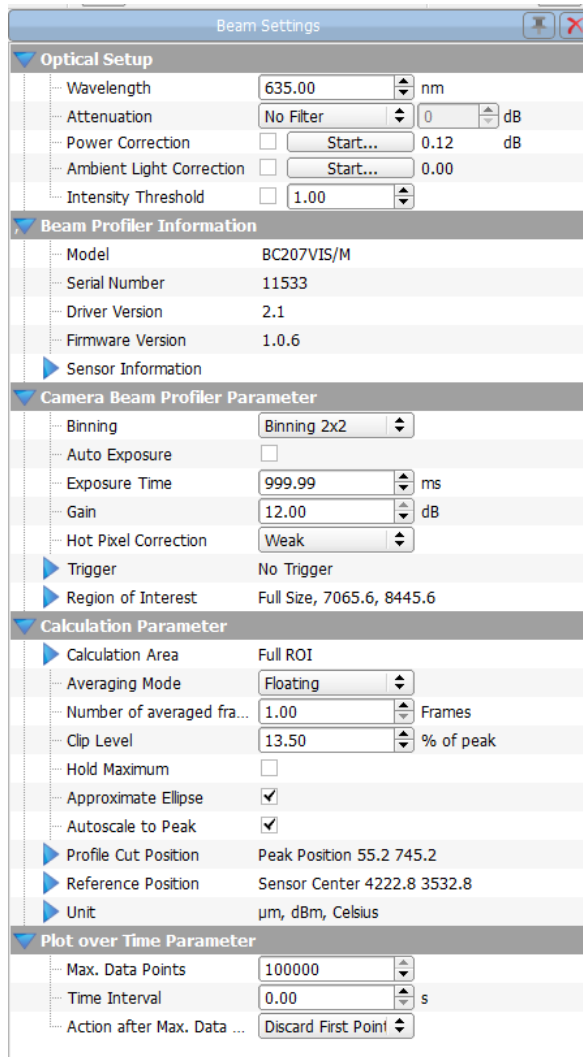

Beam Settings BC207 or BC210C Series

Please read this section carefully and follow the setup instructions in order to maximize the accuracy of your measurements.

5.4.5.1 Optical Setup

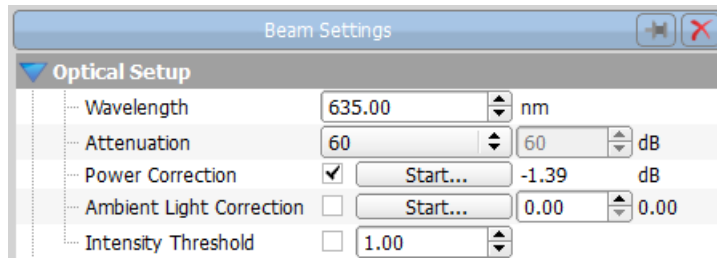

This part of the **Beam Settings** panel

- sets the [operating wavelength](#)³⁸
- sets the [attenuation](#)³⁹ in accordance with the used ND Filter
- executes a [power correction](#)³⁹
- executes [ambient light correction](#)⁴⁰
- sets the [intensity threshold](#)⁴¹

Initial Settings

When this camera is connected for the first time, the following default values are set:

Parameter	Default Value
Wavelength	635nm
Attenuation [dB]	No Filter (0 dB)
Power Correction	OFF, factory calibration active
Ambient Light Correction	OFF
Intensity Threshold	1.00

5.4.5.1.1 Wavelength

Enter the operating wavelength in nm as a precondition for proper measurement of the Total Power. It enables consideration of the known response curve stored within the Beam Profiler instrument. The correct wavelength is important for accurate Beam Quality (M^2) results as well.

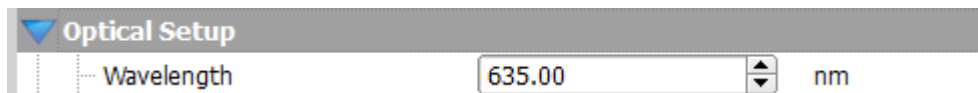

The available range is limited to 245 - 400 nm for BC207UV(/M) or BC210CU(/M) and 350 - 1100 nm for BC207VIS(/M) or BC210CV(/M), respectively.

5.4.5.1.2 Attenuation

The attenuation is given by the selection of the neutral density (ND) filter that is placed in front of the optical input. You can select a filter by rotating the [filter wheel](#)⁹. Select the **nominal attenuation** of the chosen ND filter in order to include the attenuation in the calculation of the Total Power.

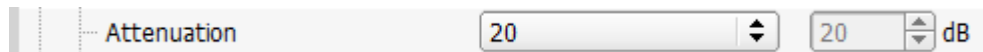

Select the active filter from the drop-down list.

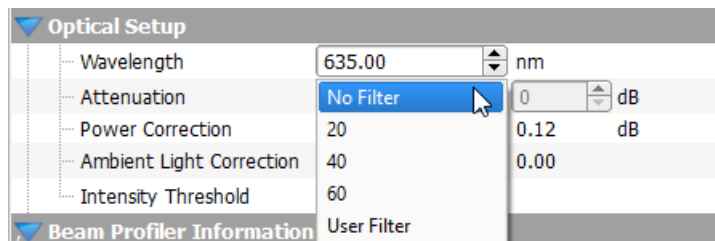

Select '**No Filter**' in the case that you have removed the filter in front of the entrance aperture so that no attenuation (0 dB) is present. For instructions on how to remove the filter please see chapter [Filter Wheel](#)⁹.

If you are using external attenuation filters or beam splitters, select '**User Filter**' and enter its attenuation value into the control on the right. Only values between 0 and 100dB are accepted by the software.

Note

The correct selection of this attenuation value is a precondition for a proper power measurement and for the [Ambient Light Correction](#)⁴⁰.

5.4.5.1.3 Power Correction

The Power Correction allows to adjust the total beam power as measured by the Beam Profiler to the power level measured by a reference power meter.

Preconditions:

Be sure that the following settings are accurate:

- Operating wavelength
- Nominal loss of the selected ND filter



Click the "Start" button - the Power Correction Dialog appears.

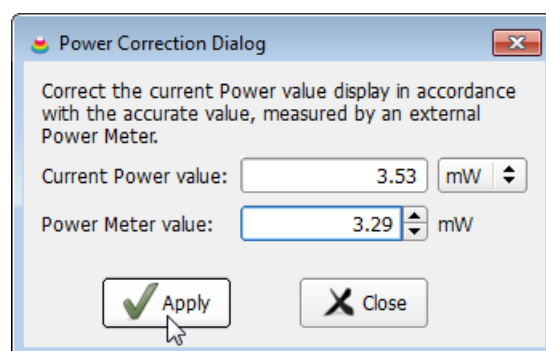

The "Current Power Value" is the power as actually measured by the integrated Beam Profiler power meter. Enter the power meter reading from the external power meter into the "Power Meter Value" control. Click "Apply" and both values will coincide. Click "Close" to leave the panel.

The difference between the power measured externally and measured by the Beam Profiler will be displayed as an offset in [dB].



This offset (in dB) is stored in the Beam Profiler and is read out and activated automatically each time after connecting this instrument.

Note

The user calibrated power reading is correct only at the actual wavelength and the selected ND filter and when the external power meter is used in the same conditions (ambient light). If any of these parameters change, the power correction needs to be repeated.

After executing the Power Correction it is activated automatically, which is indicated by the check mark.

The activation state is saved in the software. When restarting the software using the same instrument, the offset is recognized, read out and the same activation state (active / inactive) as in the previous software session will be restored.

If the power correction is not active, the attempt to activate it lets the software check the camera for a saved offset. If no saved offset is found, the Power Correction dialog opens and asks for a power meter value. If an offset is recognized, it will be applied immediately. For this reason it is recommended to perform a power correction if the environment of the instrument was changed.

5.4.5.1.4 Ambient Light Correction

It is highly recommended to shield ambient light from entering the entrance aperture as best possible, e.g. by using the supplied ND attenuation filters. However, a considerably high ambient light level may still occur within the camera image that cannot be distinguished from beam power. Accordingly, an offset level will add to the measured beam profile which leads to inaccurate beam parameters. Therefore, a correction for the remaining ambient light level is provided and should be carried out in cases where the ambient light level is measurable. An indication for this is when the far-off wings of the X Y profiles do not go down to zero intensity level.

Note

It is recommended to proceed with the ambient light correction after a 30 min warm-up time and repeat it if needed (e.g., ambient light conditions changed).



Click the 'Start' button - the Ambient Light Correction Dialog appears.

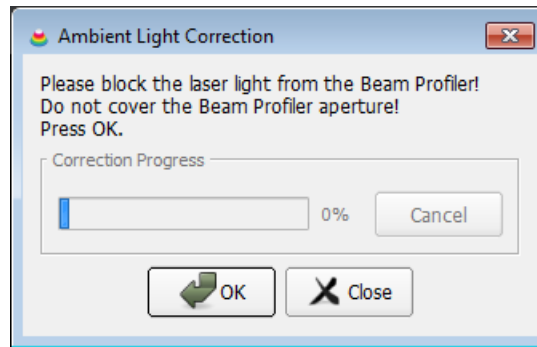

Make sure the laser is blocked, but not the ambient light, click "OK"; the correction starts.

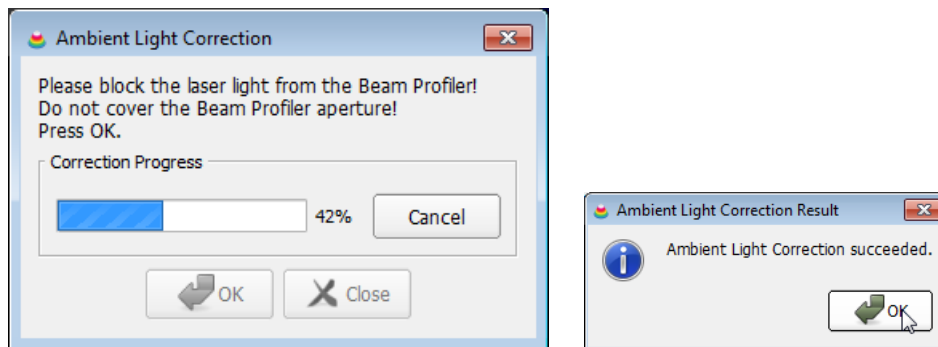

Click OK and close the Ambient Light Correction window. The Ambient Light Correction appears enabled, and the correction factor will be displayed.

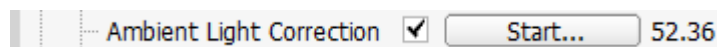

Note

- Thorlabs Beam Software uses a unique approach for Ambient Light Correction - please see details in section [Application Notes](#)¹⁶⁸.
- When ambient light power is changed or a different ND filter is used, a new correction is required, otherwise beam profiles are displayed using an unreal (positive or negative) offset and the accuracy of measurement results may worsen.
- Ambient light correction is disabled by any software restart, reconnection of a camera Beam Profiler, or change of the ND filter settings in the software.

5.4.5.1.5 Intensity Threshold

The Intensity Threshold applies to the raw data retrieved from the camera, and allows to clip the intensities below a user-defined threshold.

Warning!

Using the intensity threshold may exceed the [Calculation Area Clip Level](#)⁵¹. In such case, the calculation area will change and this way falsify the beam diameter calculation. The beam centroid position will not be affected.

A typical situation to enable the intensity threshold is, for example, the task to define the beam centroid in an environment with a high and unstable ambient light level. The changing ambient light interferes with the centroid position calculation. When applying an appropriate intensity threshold, the varying ambient light can be omitted.

The entered value is the percentage of the maximum ADC output level:

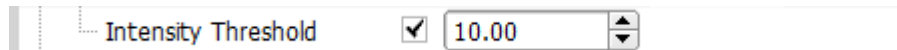

In the above example, all intensities below 10% of the ADC maximum output level are omitted.

The threshold is shown in the X and Y profiles as a dot-and-dashed line with a label, if the option **Auto Scale to Peak**  is disabled - in this case, the intensity scale of the X or Y profile displays the percentage of the ADC maximum output level:

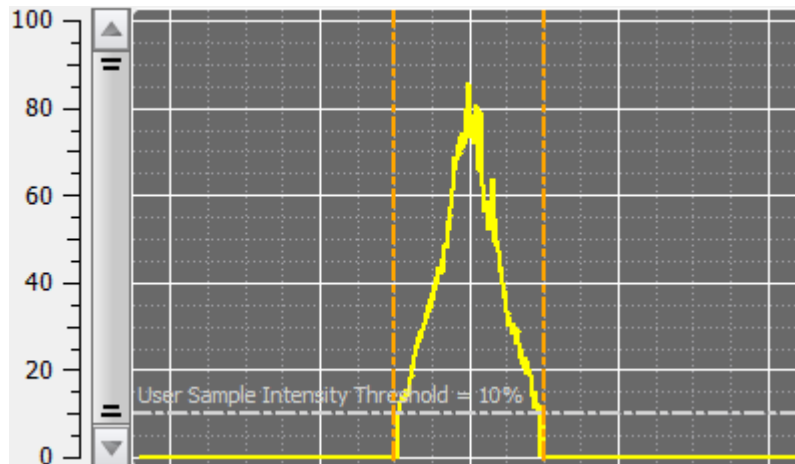

If **Auto Scale to Peak** is enabled, the intensity scale displays the percentage of the peak level, and thus, the Intensity Threshold label cannot be displayed.

5.4.5.2 Beam Profiler Information

Beam Profiler Information			
Model	BC207VIS/M		
Serial Number	11533		
Driver Version	2.1		
Firmware Version	1.0.6		
Sensor Information			
	Width	Height	
Number of active pix...	1224	1024	pix
Pixel Size	6.9	6.9	µm
Sensor Size	8.45	7.07	mm

Beam Profiler model, serial number, driver version, and firmware version are read out from the BC207 Series and BC210C Series instrument and cannot be changed. Beside general information, important sensor information is stated

5.4.5.3 Camera Beam Profiler Parameter

This chapter contains a number of important camera settings that are accessible by the user. Please become familiar with the meaning of these controls in order to prevent improper adjustments which may lead to erroneous measurement results. All visible controls are explained below.

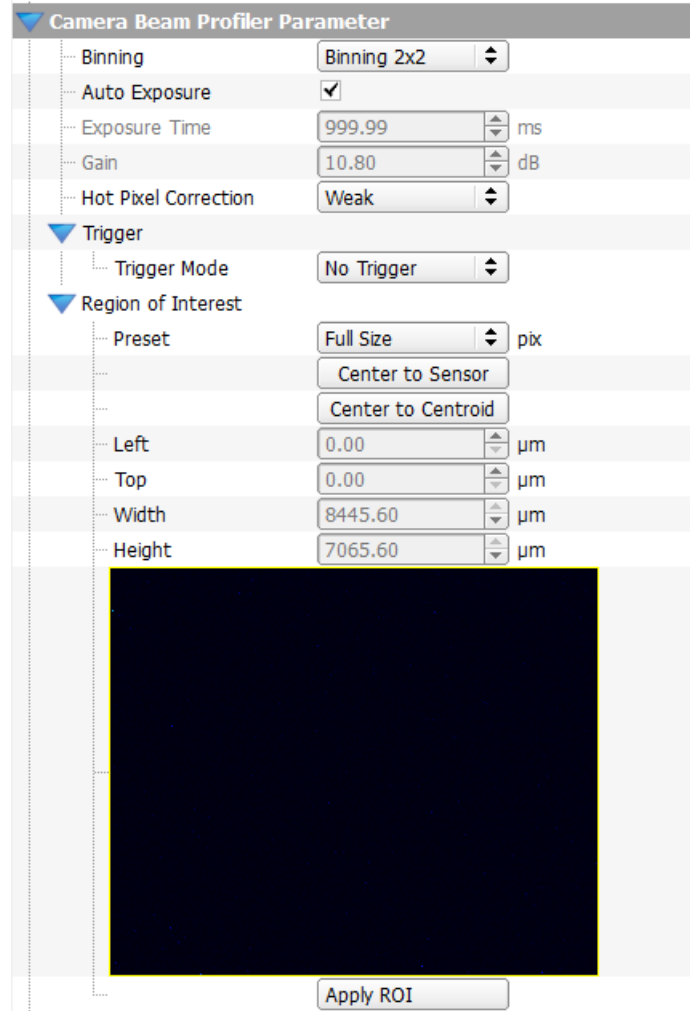

Details on the individual parameters are explained in the subsequent sections.

Initial Settings

When this camera is connected for the first time, the following default camera parameters are set:

Parameter	Default Value
Binning	Binning 2 x 2
Auto Exposure Control	ON
Exposure Time	NA due to Auto Exposure
Gain	NA due to Auto Exposure
Hot Pixel Correction	WEAK
Trigger	
Trigger Mode	No Trigger
Region of Interest	Full Size

5.4.5.3.1 Binning

Binning allows to reduce the data volume by binning 2 x 2 pixels or even more, by 4 x 4, 8 x 8 or 16 x 16. This results in shorter processing times for data computation. Please be aware that the spatial accuracy is reduced by binning.

Further, binning is very useful for weak signal to reduce the noise thereof.

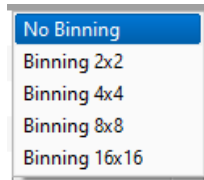

5.4.5.3.2 Exposure Control

Exposure time is the period of time when the CMOS global shutter is open and the image sensor is exposed. For CW sources there is a linear dependency between exposure time and mean image brightness. Increase the exposure time to increase brightness and vice versa.

1. Auto Exposure Control

The exposure control includes adjustments for exposure time and electrical gain factor. Both settings determine the sensitivity of the camera and need to be adapted to the actual beam power in order to ensure a nearly full scale amplitude measured by the camera's AD converter.

By default, both settings are controlled automatically in order to achieve an Image Saturation between 65 and 95% of the available AD range.

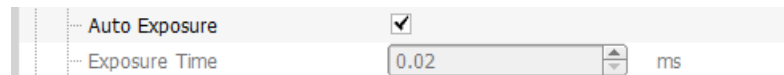

It is highly recommended to use this automatic exposure control. When activated, the Beam Profiler software will automatically adapt both the exposure time and gain. Both controls become gray and display the actually used values. The goal is to keep the brightest pixel of the selected ROI at a high saturation level but prevent saturation (100%) due to the limited range of the AD converter that is digitizing the image.

However, in case of unstable or [pulsed laser](#) power it might be advantageous or even required to disable the automatic exposure control and set the optimal values manually. For this, remove the 'Auto Exposure Control' check mark and follow the instructions below.

2. Manual Exposure Control

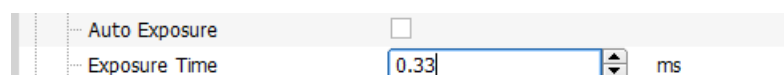

Exposure time can range from 0.03 ms to 1000 ms (for BC207) or 500 ms (for BC210C) with a step width of 0.01 ms.

Use the  arrows in order to increase and decrease the exposure time stepwise. To enter a certain value just overwrite the present one.

5.4.5.3.3 Gain Control

The Gain can be set manually only with Auto Exposure disabled.

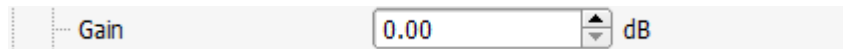

The Gain denotes the linear amplification factor of the electrical amplifier between the CMOS sensor and the AD converter. Higher gain increases image brightness, but also image noise. Therefore, it is recommended to use primarily the exposure time control for brightness adjustments.

Gain settings higher than 0.00 db should be used only if

- the exposure time is already set to its maximum value or
- the exposure time is set below 1 ms and brightness change between two successive exposure times is too large.
- pulsed laser sources are used.

5.4.5.3.4 Hot Pixel Correction

Hot pixels appear as an unwanted property of CMOS sensors and are due to different charge leakage rates between individual pixels. They appear as points of high intensity particularly at long exposure time and their intensity depends on the temperature.

Hot pixels may cause measurement errors, particularly in 4s measurements, which is important for M² beam quality measurements, and may impact the baseline definition during ambient light correction.

Thorlabs Beam offers a hot pixel correction feature.

To reduce or eliminate hot pixels from influencing the measurement, set the hot pixel correction to Weak, Moderate or Strong (maximum suppression of hot pixels). This function can be used to get the current threshold value for hot-pixel correction. The value is a quantitative measure of how aggressively the camera will remove hot pixels.

Please be aware that selection of the Moderate and, even more so, Strong hot pixel correction affects the displayed beam profile, especially whenever the beam diameter is very small or has steep edges. Selecting strong results in cleaner displayed profiles for beams with larger diameter.

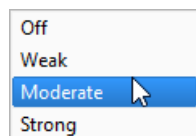

5.4.5.3.5 Trigger

The BC207 and BC210C Series Camera Beam Profilers are able to capture beam profiles of irregularly occurring optical pulses or pulsed light sources in different modes to trigger exposure with respect to the laser pulse occurrence.

Open the ['Beam Settings'](#)³⁶⁾ panel and topic "[Camera Beam Profiler Parameter](#)⁴³⁾" - "Trigger" to choose between the trigger modes: No Trigger, Software Trigger, or Single Pulse Trigger.

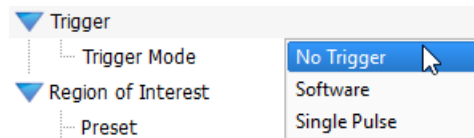

By default 'No Trigger' is chosen for continuous caption of CW light sources.

Note

The BC207 and BC210C Series Beam Profilers accommodate for the following frequency ranges:

37 kHz: The BC207 and BC210C Series Camera Beam Profiler can detect single pulses provided their frequency is lower than 37 kHz. Frequencies above 37 kHz are recognized as continuous wave signal and result in a multi pulse detection.

10 Hz: The BC207 and BC210C Series Camera Beam Profiler together with the Beam Software can discriminate each single pulse in the beam profile analysis when the pulse frequency is at maximum 10 Hz. This frequency is highly dependent on the acquisition settings and the PC. This is because the camera awaits a ready signal from the software. For frequencies between 37 kHz and 10 Hz, pulses may be skipped and not each pulse can be analyzed. In this case, the pulse following the ready signal from the software will be captured and analyzed.

1. No Trigger

This mode is dedicated mainly for use with CW sources. A constant beam power is expected so that image capturing can start at any time. This mode should be used also for pulsed sources with high repetition rates above 37 kHz. Pulse trains with a frequency above 37 kHz appear as CW signal to the camera.

In order to activate the mode, first click  in the Toolbar.

2. Software Trigger

"Software Trigger" can be used for pulsed light sources which do not provide an electrical trigger signal for synchronization to the beam profiler. Also, irregularly occurring optical pulses can be captured.

In the software trigger mode, the Beam Profiler Software processes images which exceed a brightness level set by the user. The beam profile data may not represent profiles from each discriminated single pulses one after the other. Whenever the camera is available after receiving a ready signal from the software, an image with a sufficient brightness is processed by the software. Whether the camera acquires each pulse depends on the pulse frequency and the PC. For pulse frequencies up to 10 Hz, each pulse can be resolved, given that exposure settings and PC hardware and performance are at an optimum.

Make sure the Beam Software is set to continuous measurement mode;

if not click  in the [tool bar](#)³⁴. Select "Software Trigger" in the Beam Settings panel.

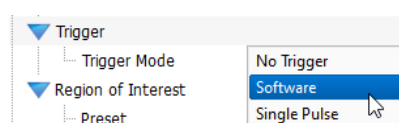

The 'Software Trigger' mode requires [manual exposure control](#)⁴⁴. An appropriate warning appears, if auto exposure is enabled:

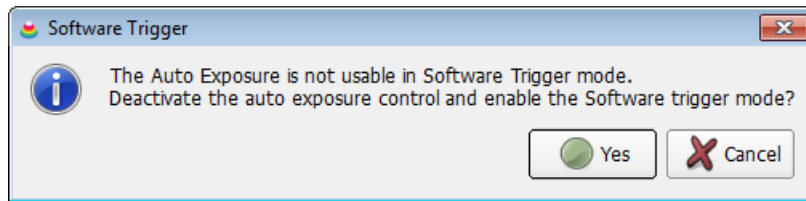

To confirm, click "Yes" and enter the desired 'Exposure Time'⁴⁴ and the 'Gain Factor'⁴⁵ manually.

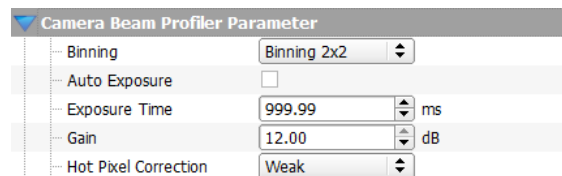

Then define the 'Min. Image Saturation' level in %, that will be the software controlled brightness trigger level.

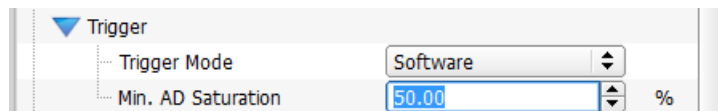

A default value of 50% indicates that only images with a half scale maximum brightness are triggered, captured and interrogated afterwards. Dark images taken by the camera with a maximum brightness lower than the selected 'Min. AD Saturation' level will be ignored and not displayed.

Adjusting Exposure Time and Gain

Adjust both the 'Exposure Time' and the 'Gain Factor' controls so that a low 'AD Saturation' (in % of full scale brightness) results when no laser pulse is captured. Increase the 'Exposure Time' and 'Gain Factor' so that a detected laser pulse exceeds the 'Min. AD Saturation' threshold. Decrease both controls in case the detected pulse reaches the limiting 100% saturation because its real intensity may be considerably higher.

The status bar informs you about the activated software trigger function.

The Beam Profiler is waiting for an image reaching the selected saturation threshold. In case the actual AD saturation level is below the threshold, the status bar informs you about a waiting software trigger event.

SW Trigger 50.00 % ▶ 71 | Attenuation: 40 dB | Exposure Time: 500.00 ms | Gain: 8.00 dB | Auto Exposure: OFF | 1.64 fps

For frequently occurring pulses it is recommended to set the Exposure Time to a slightly shorter period than the pulse period so that only a single pulse is captured.

Prevent ambient light from entering the input aperture and use one of the neutral density filters for its attenuation.

Note that the image brightness of a captured single optical pulse is not adjustable by the 'Exposure Time' control in case the single optical pulse is shorter than the adjusted exposure duration. Use the supplied ND filters of the filter wheel and the 'Gain Factor' control to adjust image brightness. In order to ensure a minimum noise level it is recommended to keep the gain value as low as possible.

3. Single Pulse

This option allows to use an external electrical [TTL trigger input](#)¹⁵ from a pulsed light source to synchronize image capturing with single pulses.

1) Please feed the TTL level trigger signal from the laser source or from the appropriate driving pulse generator into the BNC connector of the BC207 series or the SMA connector of the BC210 series.

Attention

Be sure to enter only a TTL compatible signal to the BNC and SMA jack not exceeding the range between 0.0 V and +5.5 V. Higher or lower voltages may damage the trigger input. See section [Trigger Input](#) ¹⁵ for details.

The TTL Trigger input parameters are listed in the table below:

Parameter	Value
Save Static Voltage Level	$0.0V \leq U \leq 5.5V$
Trigger Input Low	0 to 0.4 V
Trigger Input High	2.4 V to 5.5 V
Input Impedance	> 100 kΩ
Pulse Width (Min)	100 μs
Trigger Delay	0.27 μs
Trigger Input	TTL Level, LVTTTL compatible
Trigger Input Connector	BNC Jack (BC207 Series) SMA Jack (BC210 Series)

Note

Use only shielded coaxial cables for connecting the trigger source. Do not connect a trigger cable without a signal source because it may capture disturbing pulses that may trigger the shutter.

- 2) Click the icon  in the [tool bar](#) ³⁴.
- 3) Switch the camera in the beam Software to the mode Single Pulse to activate the response to a hardware trigger.

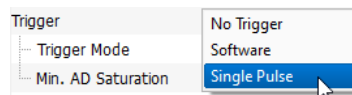

Please be aware that discrimination between single pulses is limited to about 10 Hz, highly dependent on the acquisition settings and the PC.

5.4.5.3.6 Region of Interest

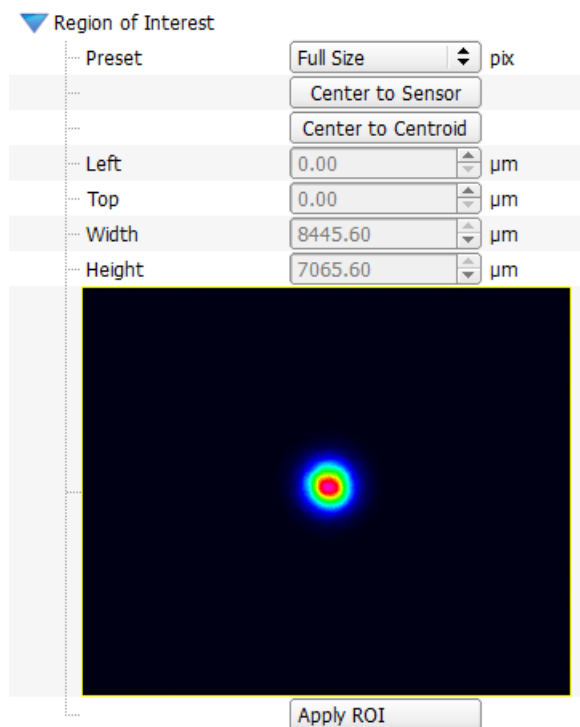

The maximum Region of Interest (ROI) is 2448 x 2048 pixel (full size) and the smallest 32 x 32 pixel. The ROI depends on the settings for binning. With the ROI parameter, the user can define a subarea within the maximum available camera sensor surface for data acquisition. Only image data of the selected ROI are transmitted from the Camera Beam Profiler to the PC so that a narrowed ROI size reduces bandwidth requirements and therefore increases measurement speed (frames per second, fps).

There are some ROI presets that can be selected from the list. To confirm, click to - this button applies the changes that were made not only to the ROI, but also to the [Center settings](#)⁴⁹ of the ROI. By selecting a predefined ROI it is automatically centered to the sensor center. See the preview image for visualizing the adjusted size which is displayed as a yellow

rectangle. To shift the selected ROI within the available sensor area click right into this rectangle and drag the mouse; the "Preset" name changes immediately to User Defined.

User Defined ROI

A user defined ROI can be easily defined by drawing a rectangle into the preview image (click left, hold down and draw a rectangle). The last preset value is replaced automatically by "User Defined" and the chosen ROI size and position is displayed within the controls on the right. These values can also be modified by entering the desired Width, Height, Left and Top values into the appropriate controls. Its unit can be switched between pixels or μm .

Note

The ROI point of origin (0,0) is located in the upper left corner of the entire sensor area so that 'Left' and 'Top' describe the upper left ROI borders with respect to this corner. In contrast to that, measurement coordinates X and Y are defined with respect to the center of the ROI, see below.

Center

Any user defined ROI can be centered to either the sensor center or to the centroid of the measured beam. The latter may be useful if the beam centroid is located far away from the sensor center and the user defined ROI does not cover the sensor center.

When the measured beam is considerably smaller than the Camera Beam Profiler aperture, it is advisable to limit the area captured by the camera. Reduce the image area by determining a ROI that is well filled by the beam. However, it is not recommended to narrow ROI too much - lower intensity areas surrounding the laser beam will be cut off! This may lead to incorrect numerical results (for instance Beam Centroid position) or even prevent calculation of the beam width because the selected clip level (default 13.5% of the peak intensity) is not reached within the ROI.

Please enlarge the ROI when the beam under test does not fit to the selected ROI area. The ROI height and width should be at least two times the beam width.

Note

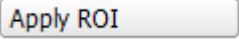
Do not forget to click the  button, as soon as it becomes highlighted green!

Note

The Beam Profiler's point of origin ($X = 0, Y = 0$) is always fixed to the center of the entire sensor area so that X and Y coordinates have a bipolar range. Shifting the ROI off-center will maintain the calculated beam position because these data are bound to the entire sensor area and not to the relative ROI coordinates.

5.4.5.4 Calculation Parameter

This section in the [Beam Settings](#)^[36] is used to set parameters for beam profile calculation. Shown below is the view of the Calculation Parameter section at the first start of the Beam Software or after pressing the "[Reset Application Settings to Defaults](#)"^[32] button  in the toolbar:

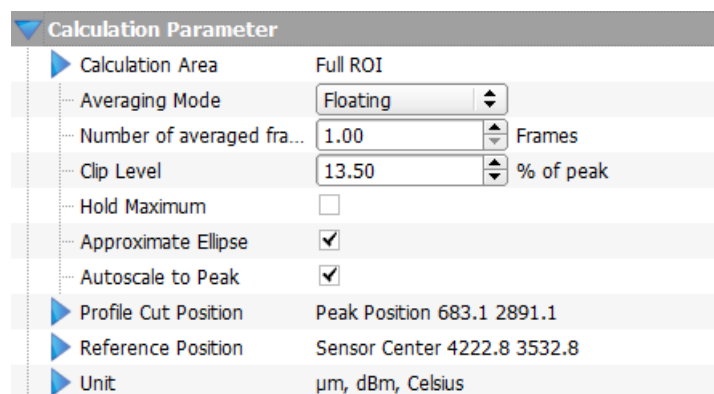

5.4.5.4.1 Calculation Area

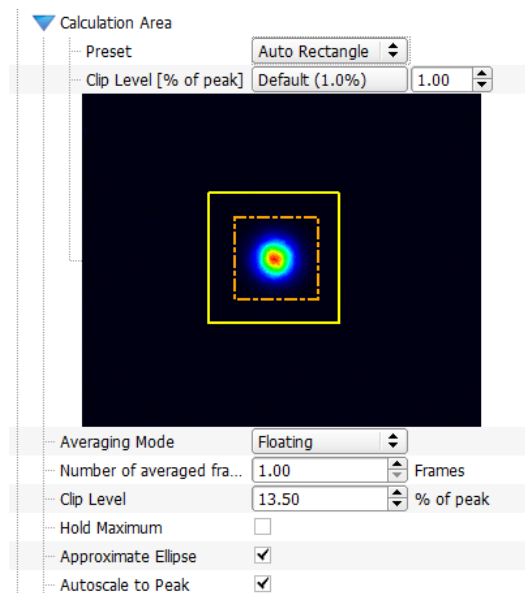

The Calculation Area defines a specific area within the already selected Region of Interest (ROI), see [Camera Beam Profiler Parameter](#)^[43]. Whereas the ROI determines the image area that is retrieved from the camera and displayed, the Calculation Area can be equal to or smaller than the ROI and defines the image area, that is used for all numerical calculations. That is, all pixels within the ROI are displayed while only the pixels within the Calculation Area are used for calculations.

Such a limitation is especially advantageous for:

- Selecting and analyzing only a single beam spot among multiple beams
- Rejecting ambient or stray light
- Reducing measurement noise
- Increasing performance

Note

It is advisable to set the camera ROI to the smallest feasible area instead of working with a large ROI and shrinking the Calculation Area afterwards. This will increase measurement speed.

Six presets are provided to choose a Calculation Area.

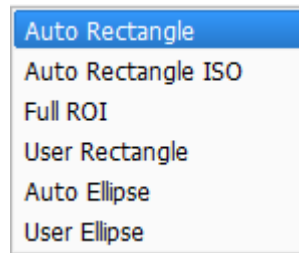

- Auto Rectangle:** The software will analyze every image from the BC207 and BC210C Series automatically and determine the area in which a measurable amount of power is present. Areas with a power level lower than the [clip level](#)^[51] will be excluded from further calculations.
- Auto Rectangle ISO:** The rectangular calculation area is calculated according to ISO11146-1 using multiple iteration steps. The clip level is determined during the calculation.
- Full ROI:** The entire image area defined by the ROI is involved in beam calculations.
- User Rectangle:** A rectangular area, set by user input is defined as Calculation Area. Enter pixel values which describe the Calculation Area position and size or simply drag a rectangle into the 2D Projection window.
- Auto Ellipse:** An elliptical area is created automatically by the software around the beam shape. Criteria: [Clip Level](#)^[51]. Areas with a power level lower than the clip level will be excluded from further calculations. The clip level can be set up in the Application Settings.
- User Ellipse:** An elliptical area, set by user input, is defined as Calculation Area. Enter pixel values which describe the Calculation Area position and size or simply drag an ellipse into the 2D Projection window.

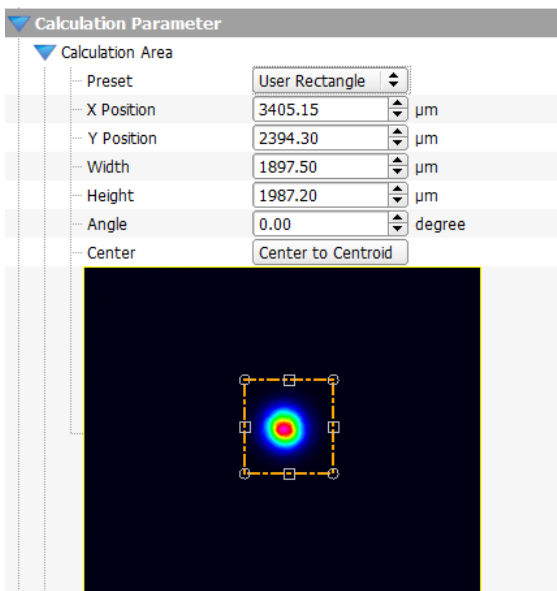

When "User Rectangle" or 'User Ellipse' is selected, please enter size and position of the Calculation Area numerically or drag and drop the borders of the user rectangle (ellipse). All values are in μm or pixels, depending on the [unit selection](#)^[54], and the point of origin is situated in the upper left corner of the entire sensor area. X (Y) Positions describe the position of the left (upper) border of the user rectangle (ellipse). Further, a defined calculation area can be rotated by entering numerically the desired rotation angle.

The Calculation Area can also be set and visualized within the [2D Projection](#)^[58] window. See the appropriate chapter for details.

Clip Level of the Calculation Area

If the calculation area is detected automatically (**Auto Rectangle** or **Auto Ellipse**), the borders of the Calculation Area in all four directions are defined by the calculation area clip level. The border in one direction is set when all pixel values fall (seen from the peak) below the Clip Level. Decreasing the Clip Level increases the Calculation Area which in return increases for example the 4σ diameters, but also

increases the noise. For a steep beam profile, 1.0% is an optimal clip level value. If the beam profile is rather flat, it might be advantageous to lower the clip level.

The clip level is set by default to 1 % and can be set between 0.01 and 13.5 %. In order to quickly return to the recommended 1.0% clip level, just click to the box *Default (1.0%)*.



Note The "*Clip Level of Calculation Area*" is different from the [Clip Level](#)^[52] used for beam profile calculations!

Attention

The calculation area must not cut off lower intensity parts of the beam profile. This may cause inaccurate calculation results!

Note

When the ROI size or position is changed and the Calculation Area was not set to 'Automatic' and does not fit into the new ROI, the Calculation Area will be reset to 'Full Size', in other words, to the new ROI.

5.4.5.4.2 Averaging Mode

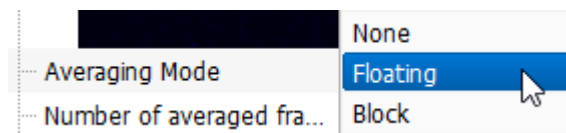

Two modes are available - floating and block.

When using an averaging mode, please also define the number of averaged frames, which can be set from 1 to 100.

In **Floating mode**, the average is calculated from the weighted previous average and the recent frame. Example: Floating average is made for 10 frames. The previous average value is multiplied by 9, then the recent frame value is added and the sum is divided by 10, which gives the new average value.

In **Block mode**, the indicated number of frames is accumulated, after acquisition the average is calculated and displayed. This is the slowest mode.

Setting the frames to numbers higher than 1 enables noise reduction.

This option is helpful for unstable light sources with fluctuating intensity or beam shape, or if the update rate on the screen is too high for easy data readout. Also use this option to suppress Beam Profiler noise in case of low intensity.

5.4.5.4.3 Clip Level

In contrast to the [Calculation Area Clip Level](#)^[51], the **Clip Level** parameter is used to determine the beam width. It defines a relative intensity level between dark level (0%) and peak level (100%) of the measured beam profile at which the beam width is determined. The ISO11146 Standard recommends a default value of $1/e^2 = 13.5\%$ of the peak intensity. Other values from 5% to 95% can be set by entering manually.

Click on *Default (1/e²)* to set the default Clip Level of 13.5%. See Appendix [Application Note](#)^[171] for details.

5.4.5.4.4 Hold Maximum

The **Hold Maximum** feature is recommended for pulsed laser sources. In all subsequent scans for each pixel only the maximum values are stored, displayed and used for calculation.

In comparison to the [software trigger](#)¹⁵ function of the Beam Software, Hold Maximum will only store and analyze maximum values, while in software trigger, a threshold can be set.

5.4.5.4.5 Approximate Ellipse

Enable the **Approximate Ellipse** check box in order to get the best fitted beam ellipse. This setting provides more stable and reliable ellipse results.

Otherwise, ellipse data are retrieved from single minimum and maximum diameters of the elliptical beam cross section. These results are more noisy and therefore less reliable than the fitted results.

5.4.5.4.6 Autoscale to Peak

Enable the "**Autoscale to Peak**" check box to scale the X and Y profiles to their peak intensities. Disabling will scale the X and Y profiles to the value of AD saturation.

5.4.5.4.7 Profile Cut Position

The profile cut position determines the location of the crosshair in the [2D Projection](#)⁵⁹.

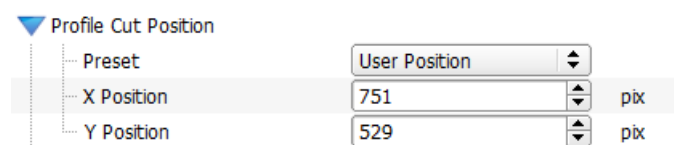

The position of these X and Y cross sections can be fixed to the ROI Center, to the centroid, to the peak, or to a user defined position.

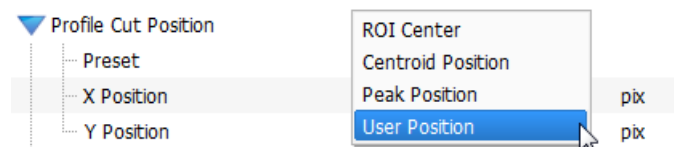

For the user defined position, the X and Y positions are to be entered numerically.

5.4.5.4.8 Reference Position

The reference position influences the calculation results. Peak and Centroid positions refer to the reference position. By default, the reference position is set to the sensor center. In the 2D Projection window it is displayed as a grey crosshair.

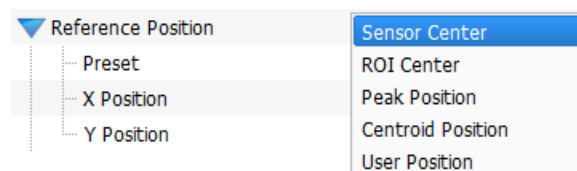

The Reference Position can be set to predefined positions (see above) or to a user defined position. The X and Y coordinates of a user defined position are to be entered numerically or set in the [2D Projection](#)⁵⁹ (Reference Position Editor):

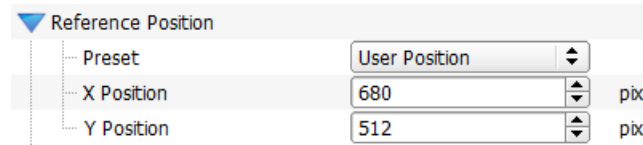

5.4.5.4.9 Unit



The measurement units that are displayed in the Beam Software can be selected in the **Unit** topic.

- Position units: **µm or pixel.**
- Total Power units: **mW or dBm.**
- Temperature: **°C, °F or K.**
(Temperature is measured inside the camera.)

The following table gives an overview on all available units:

Unit	Description
pix	Location, width or distance, related to the image sensor pixels. The origin of the coordinate system (X=0, Y=0) is the sensor center, not the image center! Positive X values go to the right, positive Y values to the top of the image.
µm	Location, width or distance in µm, calculated from the camera pixels. 1 pixel = 6.45 µm. The origin of the coordinate system (X=0, Y=0) is the sensor center, not the image center! Positive X values go to the right, positive Y values to the top of the image.
mW	The Total Power of the beam is calculated from the integral intensity of the image using the wavelength dependent sensor response, the Exposure Time and Gain of the camera as well as the filter attenuation and the power correction value.
dBm	The Total Power translated from mW into dBm: $10 * \log (P[mW])$, 0 dBm refers to 1 mW.
%	Relative level between 0 and 100%.
deg	Angle in degree with respect to the X axis, range -90° to +90°.

5.4.5.5 Plot Over Time Parameter

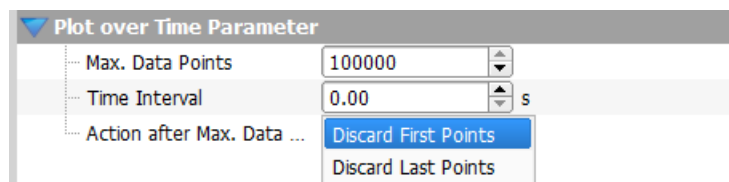

The Beam Software allows to show different plots of beam measurements:

- [Plot Positions](#) ⁷⁵
- [Plot Power](#) ⁷⁶
- [Plot Diameters](#) ⁷⁷
- [Plot Gaussian Fit](#) ⁷⁸

[Plot Orientation](#)⁷⁹ [Plot Environment Data](#)⁸⁰
[Beam Stability](#)⁸¹

The section **Plot Over Time Parameter** is used to configure these plots:

- The maximum number N of data points in the plots can be defined (N=1 to 100000).
- The time interval between two data points can be selected (between 0 = every measurement to 1000 s; default = every measurement).
- Specify the action performed after the maximum number N of recorded data points is reached:
 - "Discard First Points" means the 1st data set is discarded and the most recent data point will be added to the plot. In other words, after reaching the maximum number N of plotted data points, the plot continues and displays the most recent N data points.
 - "Discard Last Points" means that all data points beyond N will be discarded. In other words, after reaching the maximum number N of data points, the plot stops.

5.4.5.6 Translation Stage Control

If a translation stage is detected as is the case when a M2MS measurement extension is connected and powered, the topics "Translation Stage Control" and "M² set" appear as the last two topics of the Beam Settings panel. The description in this section assumes a Thorlabs DDS100 Linear Translation Stage, as it is used in the [M2MS Extension Set](#)⁹⁴.

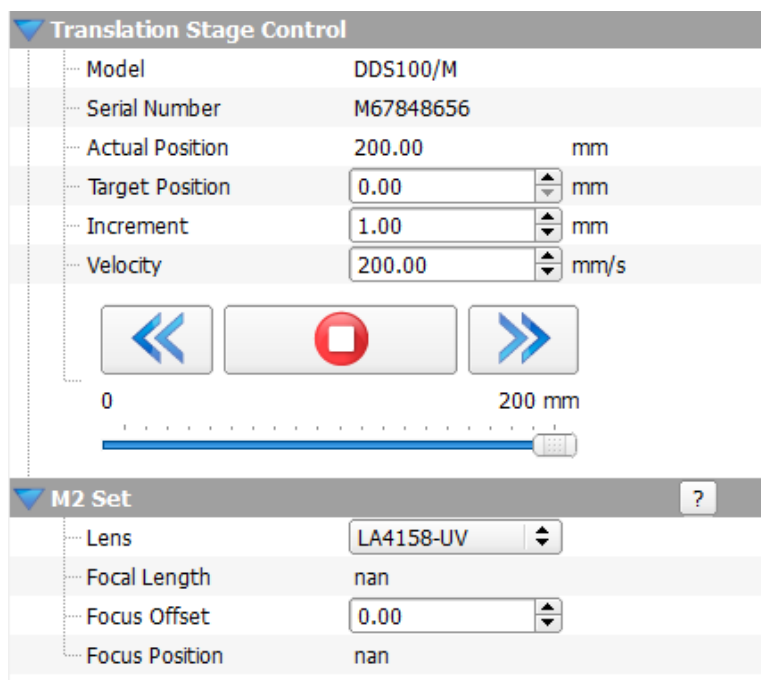

This panel allows the user to manually control the translation stage. This is useful for a coarse setup of the M² or [Divergence Measurement](#)¹²⁹.

Actual Position displays the present stage position.

Target Position: Enter a value between 0 and 200 mm, press "Enter" on your keyboard, and the stage will travel with the set **Velocity** (see below) to the new position.

Note

The total displacement reaches from 0 to 200 mm, although the stage translation path is only 100 mm. This results from the mechanical design of the [M2MS⁹⁴](#) M² Meter Set.

Increment: Enter the increment for moving the stage stepwise.

Velocity: This is the speed of the stage when traveling between two positions (e.g., between the actual and the target position).



Pressing these buttons moves the stage backward / forward for one step, equal to the **Increment**.



Pressing this button interrupts the continuous stage travel to a target position.

The slider bar on the bottom of the panel has two functions - it shows the stage position, and the slider can be moved with the mouse in order to start a stage travel.



M2 Set

The panel "M2 Set" allows to set the lens parameters for the M2MS extension such that the beam waist before the lens can be calculated. The Lens Type and Focus Offset are chosen by the user. The software calculates the focal length and beam waist based on the provided information, including the wavelength as set above under [Optical Setup³⁸](#).













The focus position is then determined based on internal M2MS parameters, the type of beam profiler, the focus offset and the determined focal length.

5.4.6 Child Windows

When starting the application first time, three child windows are opened and arranged automatically:

- [2D Projection](#) 
- [3D Profile](#) 
- [Calculation Results](#) 

The application also provides other windows:

- [X Profile](#) 
- [Y Profile](#) 
- [Plot Positions](#) 
- [Plot Power](#) 
- [Plot Diameters](#) 
- [Plot Gaussian Fit](#) 
- [Plot Orientation](#) 
- [Plot Environment Data](#) 
- [Beam Stability](#) 
- [Beam Quality \(\$M^2\$ \)](#) 
- [Manual Vergence Measurement](#) 
- [Tuning View](#) 
- [Beam Overlapping](#) 

All above windows can be opened and closed by clicking the symbols in the toolbar or by selecting the entries in the menu "Windows". Additional child windows are accessible through the [menu bar](#) .

The appearance of the Thorlabs Beam Software can be arranged according to your requirements and taste. All child windows can be re-sized and flexibly positioned. Here is an example of arranging some child windows:

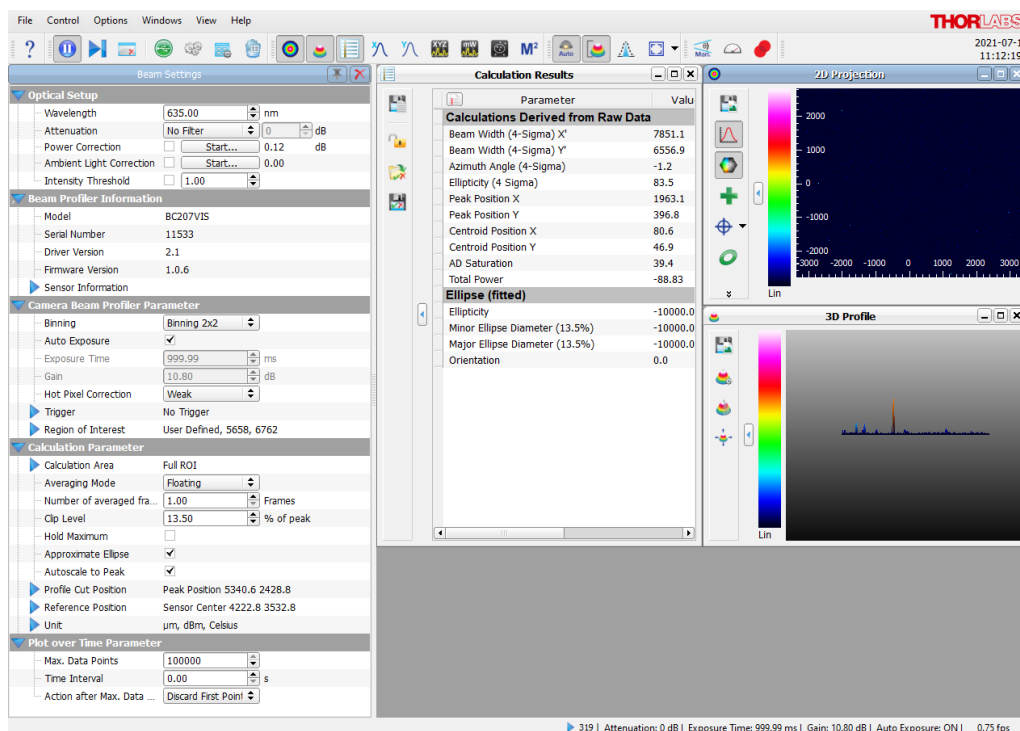

To close a child window deselect the menu entry or the appropriate toolbar symbol or click the close button "X".

Each child window can be moved and resized. If a child window is closed, size and position are stored and recovered when it is reopened.

When the GUI application is closed and reopened, the main panel will have the same child panels open in their former positions. To arrange the windows automatically use the function "Tile View" from the "View" ³³ menu.





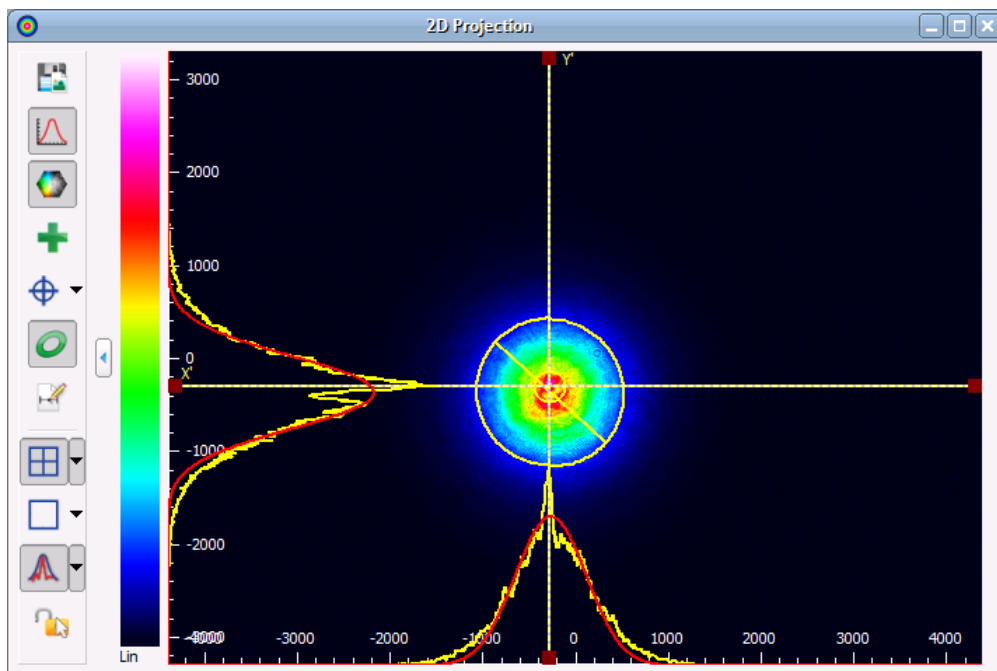

5.4.6.1 2D Projection







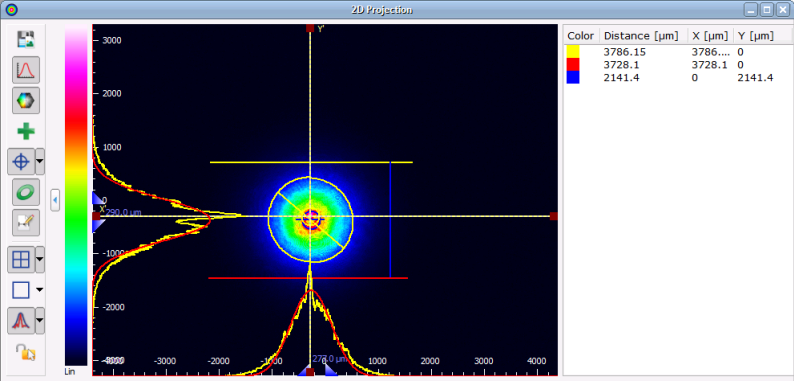

The 2D Projection graph shows the image from the Beam Profiler with the power intensity distribution within the selected Region of Interest (ROI).

This window can be opened and closed via the menu item "2D Projection" in the window menu or via the toggle button  in the toolbar.



On the left side of the 2D Projection window a toolbar is located with the following toggle buttons:

Toolbar Icon	Associated Action
 Save Diagram or Image	Opens a dialog box to specify the properties of the saved screenshots / diagrams.
 Scale	Show or hide the x and y scale
 Color	Changes the color of the image from gray scale to color (see Display Settings ³⁰)
 Peak	Marks the Peak Position using a green cross
 Centroid	Marks the Beam Centroid using a blue cross within a blue circle; resets the centroid indicators
 Ellipse	Displays the approximated Beam Ellipse in yellow color. The ellipse is drawn corresponding to fitted or unfitted numerical data. See Beam Settings ⁵³ to enable/disable the ellipse fit.

Toolbar Icon	Associated Action
 <p>Distance Measurement Mode</p>	<p>The distance measurement editor opens a table beside the projection image. When drawing lines into the projection image, the distance is inserted into the table. A maximum of 10 distances can be drawn. Remove a distance entry by selecting the entry and pressing the "DEL" key or select the entry and choose the "Delete Distance" entry from the context menu.</p> 
 <ul style="list-style-type: none"> • Set Reference Position to Sensor Center Set Reference Position to ROI Center Set Reference Position to Peak Position Set Reference Position to Centroid Position Set Reference Position to User Position 	<p>The reference position for calculations can be displayed or hidden as a grey crosshair by toggling the  button. A drop-down menu allows to set the reference to typical positions or to define a user position. Detailed explanations please see in section Beam Settings ⁵³.</p>
 <ul style="list-style-type: none"> • Set Calculation Area Automatic Set Calculation Area Automatic ISO Set Calculation Area to Full Size Set Calculation Area by User Set Calculation Area Automatic Ellipse Set Elliptical Calculation Area by user 	<p>The Calculation Area is a subarea of the ROI. It can be displayed or hidden by toggling the  button. Only pixels within this Calculation Area are interrogated and recognized for beam data calculation.</p> <p>A drop-down menu allows to make a choice from several presets; additionally a rectangular or elliptical calculation area can be defined by the user. Detailed explanations please see in section Beam Settings ⁵⁰.</p>
 <ul style="list-style-type: none"> • Fix Crosshair to Center Fix Crosshair to Centroid Fix Crosshair to Peak Fix crosshair to User Position <hr/> <p>Reset the Angle to 0</p> <hr/> <ul style="list-style-type: none"> ✓ Show Profile Curve ✓ Show Fit Curve 	<p>The crosshair, that shows the X and Y profile cuts for calculation, can be displayed or hidden by toggling the  button.</p> <p>The position of these X and Y cross sections can be fixed to the ROI Center, the centroid, the peak or to a user defined position. Additionally, X and Y profiles and their curve fits can be drawn into the 2D graph displaying the power distribution within a horizontal and a vertical cross section.</p> <p>Please see also section Beam Settings ⁵³.</p>
	<p>This button locks or unlocks the mouse interactions within the 2D Projection.</p>

If the window height is smaller than the full toolbar, the lower symbols are packed into a context menu which is accessible via an arrow button on the bottom of the toolbar.

Attention

The calculation area must not cut off lower intensity parts of the beam profile. This may cause improper calculation results!

The following graph shows an example of a chosen ROI and Calculation Area:

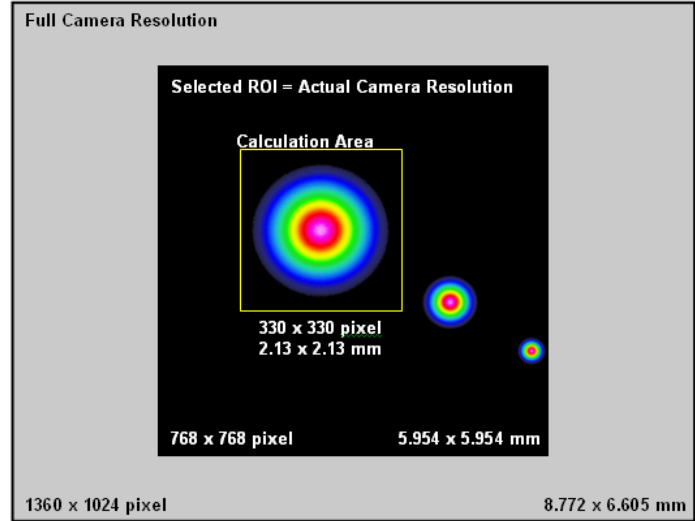

Example:

The beam in this example enters the Beam Profiler several times: once directly and additionally from multiple reflections. The ROI is selected to 768x768 pixels so that all 3 beams are visible within the 2D Projection window. But, in order to limit the image interrogation to the main beam the calculation area was chosen much smaller.

Within this 2D Projection panel, coordinates X and Y are defined as follows:

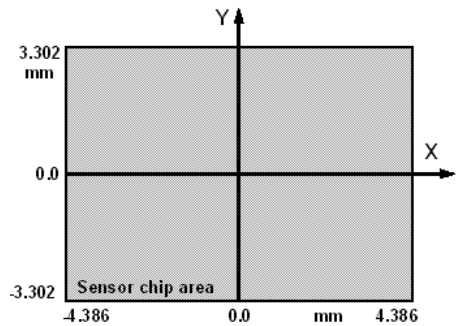

Independent of the selected unit (pixel or μm) within the Application Settings panel (see [Beam Settings, Unit](#) ⁵⁴), the origin of the coordinate system is the selected reference position. Horizontal axis is X and vertical axis is Y. Both axes are also labeled on the Beam Profiler housing.

5.4.6.2 3D Profile

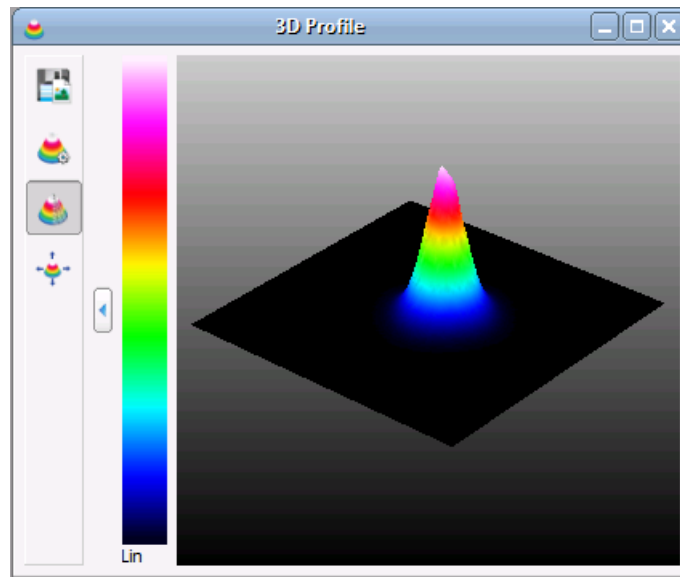





The 3D Profile illustrates the power density distribution of the measured optical beam. Whereas the beam's cross-section is parallel with the X-Y-plane, the relative power intensity is shown in the Z direction (Pseudo 3D). This window can be opened and closed via the menu item "3D Profile" in the window menu or via the toggle button  in the toolbar.

The 3D profile can be moved, rotated and zoomed with the mouse:

- Rotate:** Press right mouse button and move mouse
- Move:** Press left mouse button and move mouse
- Zoom:** Scroll mouse wheel

The following table summarizes the toolbar symbols available within the 3D Profile window and its appropriate action.

Toolbar Icon	Associated Action
	Opens a dialog box to specify the properties of the saved screenshots / diagrams.
	Opens the 3D Profile Settings dialog box.
	Toggles the appearance of the profile between solid to wired (default).
	Resets the manipulations of translation, rotation and zoom to the default view.

Position, size and rotation angle are also displayed within the 3D Profile Settings dialog box. Numerical values can be set to define the 3D Profile appearance:

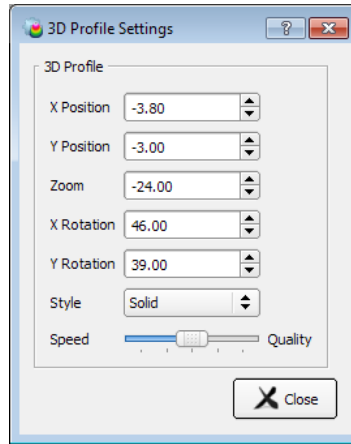

Note

- If the slider "Speed - Quality" is in the far right position, the 3D image is displayed with highest quality, i.e., with full resolution.
- The higher the 3D image quality is set, the more system resources are used. Depending on the system capabilities, the software may slow down.

5.4.6.3 X and Y Profiles

Both windows can be opened and closed via the menu item "X Profiles" or "Y Profiles" in the window menu or clicking on the appropriate toolbar symbols.

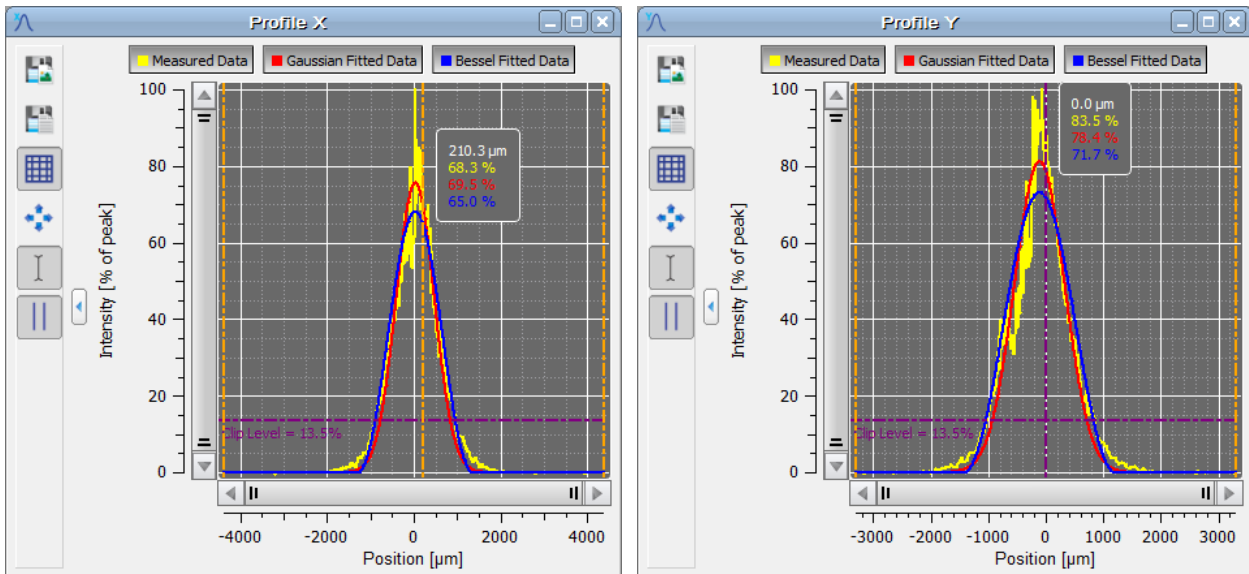

The X profile displays a single pixel row taken from the received camera image, while the Y profile shows a single pixel column. The column and row are defined by the position of cross hair within the [2D Projection](#) graph.

The yellow curve shows the measured profile, while the red curve shows the approximated [Gaussian](#) fit function and the blue - the approximated [Bessel](#) fit. The curves can be shown / hidden by toggling the appropriate button above the diagram.







If "Autoscale to Peak" is enabled and the cross hair in 2D projection is fixed to peak, the measured curve shows relative intensities from 0 to 100%, where 100% denotes the maximum value in the selected row / column.

If the "Autoscale to Peak" function is disabled, the X and Y profiles will show a peak amplitude equal to the AD converter saturation.

The amplitude of the Gaussian fit curve may be lower or even higher than the peak intensity of the measured curve.

The selected clip level (default 13.5%) is displayed if the "Auto Scale to Peak" function is enabled (button ).

The horizontal scale is displayed in pixels or μm and its range refers to the selected [Region of Interest](#) ⁴⁹. The unit of the scale can be changed in the [Beam Settings / Unit](#) ⁵⁴ dialog.

Toolbar Icon	Associated Action
	Opens a dialog box to specify the properties of the saved screenshots / diagrams.
	Opens a dialog box to save measurement data to XLS or CSV file.
	Toggle button to display grid in the diagram. Default: grid is shown.
	Zoom Home button
	Cursor mode - toggle button to show or hide the cursor.
	Show / Hide calculation area

Cursor Mode

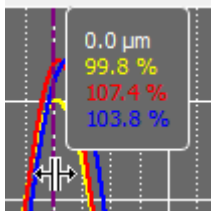

Move the mouse pointer close to the vertical cursor line. The mouse pointer changes to . The cursor line can be moved with the left mouse button pressed to a position inside the diagram. The current values at the cursor position are shown in a rectangle next to the cursor in the colors of the plotted curve.

5.4.6.4 Zooming and Panning Diagrams

All diagrams, e.g. X and Y profiles, plot diagrams, M^2 and divergence diagrams, that have a slider, can be manipulated for X and Y scale (zoom) as well as for X and Y positioning (pan).

Zoom Mode



To zoom in the diagram, draw a rectangle with the left mouse button pressed. Right click the diagram to revert to the last zoom action.



Zoom Home button returns to display of the complete diagram.

Zooming the Diagram Axes



Move the mouse cursor over an edge of the vertical or horizontal scroll bar slider. The cursor changes to  or . Press and hold left mouse button and move the mouse. This will zoom in on the appropriate part of the diagram axis. Return to default view using the Zoom Home button.

Panning the Diagram Axes



Move the mouse pointer over the center of the vertical or horizontal scroll bar slider and press left mouse button. Now the slider can be moved to pan (shift) across the diagram. Return to default view using the Zoom Home button.

5.4.6.5 Calculation Results

In this window the results of the calculations are displayed as derived format the raw data or the fitted ellipse. The window can be opened and closed via the menu item "Calculation Results" in the window menu or via the toggle button in the toolbar .

Parameter	Value	Unit	Test	Min.	Max.
Calculations Derived from Raw Data					
Beam Width (4-Sigma) X'	1183.6	µm	<input type="checkbox"/>	0.00	690.00
Beam Width (4-Sigma) Y'	1128.9	µm	<input type="checkbox"/>	0.00	690.00
Azimuth Angle (4-Sigma)	8.1	°	<input type="checkbox"/>	0.00	90.00
Ellipticity (4 Sigma)	95.4	%	<input type="checkbox"/>	0.00	100.00
Peak Position X	948.8	µm	<input type="checkbox"/>	0.00	690.00
Peak Position Y	-10.4	µm	<input type="checkbox"/>	0.00	690.00
Centroid Position X	59.8	µm	<input type="checkbox"/>	0.00	690.00
Centroid Position Y	121.3	µm	<input type="checkbox"/>	0.00	690.00
AD Saturation	39.5	%	<input type="checkbox"/>	0.00	100.00
Total Power	-29.57	dBm	<input type="checkbox"/>	0.00	100.00
Ellipse (fitted)					
Ellipticity	95.3	%	<input type="checkbox"/>	0.00	100.00
Minor Ellipse Diameter (13.5%)	652.3	µm	<input type="checkbox"/>	0.00	690.00
Major Ellipse Diameter (13.5%)	684.7	µm	<input type="checkbox"/>	0.00	690.00
Orientation	-50.2	deg	<input type="checkbox"/>	0.00	100.00

The width of the columns is predefined but can be resized. With the first start of the Beam Software, the parameters as shown above are displayed in this table. Click the marked green  icon in the table in order to select or deselect parameters to be calculated and displayed. The fewer calculation results are enabled, the higher the speed performance of the software.

Select / Deselect All

Calculations Derived from Raw Data

Beam Width (4-Sigma) X
 Beam Width (4-Sigma) Y
 Beam Width (4-Sigma) X'
 Beam Width (4-Sigma) Y'
 Azimuth Angle (4-Sigma)
 Ellipticity (4 Sigma)
 Beam Diameter (4-Sigma)
 Effective Beam Diameter
 Peak Position X
 Peak Position Y
 Peak Position R
 Centroid Position X
 Centroid Position Y
 Centroid Position R
 AD Saturation
 Total Power
 Effective Area
 Peak Density

Ellipse

Ellipticity
 Minor Ellipse Diameter
 Major Ellipse Diameter
 Mean Ellipse Diameter
 Eccentricity
 Orientation

Profile Measurement

Beam Width Clip X
 Beam Width Clip Y

Fit Measurement

Gaussian Intensity X
 Gaussian Intensity Y
 Gaussian Diameter X
 Gaussian Diameter Y
 Bessel Intensity X
 Bessel Intensity Y

Camera Temperature

Power Meter

◀ ||| ▶

Note





- Even if the Gaussian and / or Bessel Fit calculations are disabled from display in the Calculation results panel, the appropriate fitted curves are still shown in the X and Y Profile windows, if enabled there.
- Centroid Position: This parameter is very sensitive to ambient light which may shift the calculated centroid! See [Ambient Light Correction](#)^[40].

The units of the calculations can be changed in [Beam Settings / Unit](#)^[54].

If a calculation failed the value turns to "--".

For details on these parameters, please see section "[Application Note](#)"

Handling of Calculation Results and Settings

Toolbar Symbol	Associated Action
	Save Calculation Results
	Lock / Unlock Test Parameters
	Load Test Parameter Configuration
	Save Test Parameter Configuration

Save Calculations opens a dialog box:

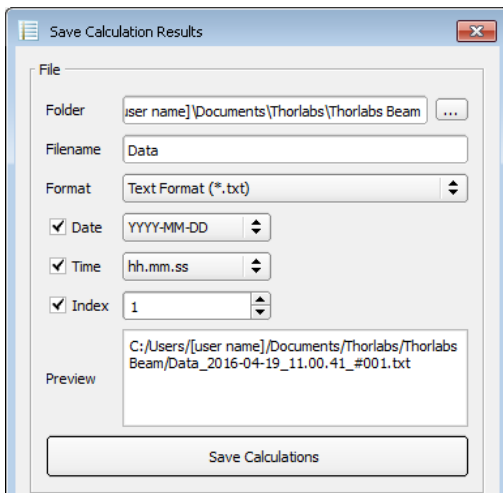

- Select the destination folder (see the preview pane)
- Define the file name
- Select file format (*.txt, *.csv or *.xls)
- Add date, time stamp, index (optional)
- Click "Save Calculations"

Lock / Unlock Test Parameters; Load / Save Test Parameter Configuration.

These functions are related to the configuration of the [Pass / Fail Test](#) functionality.

Sequential Saving

This feature is used to save sequentially sets of the [selected calculation results](#)⁶⁴, e.g for a long term analysis.

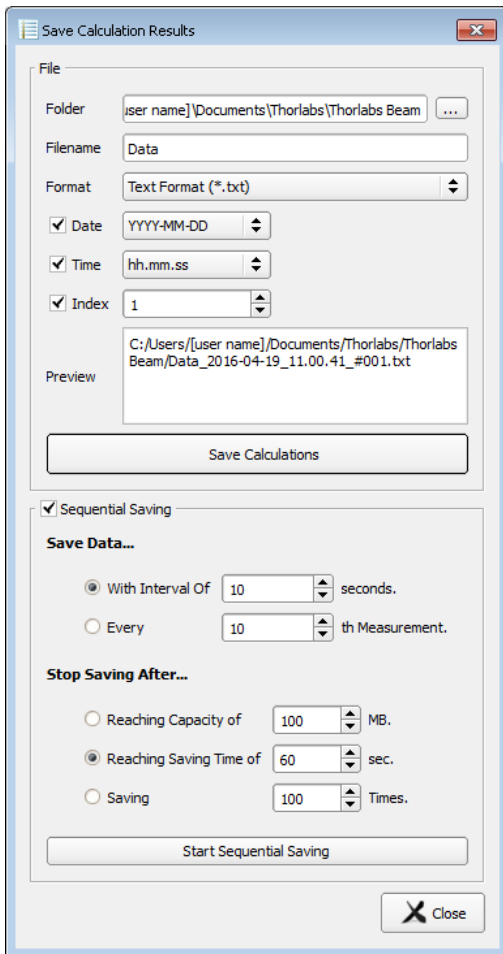

- Select the destination **folder** (see the preview pane).
- Define the file name.
- Select the export format.
- Add date and/or time stamp (optional)
- **Save Data...** Select either
 - the time interval between two records (1 to 10⁶ sec.)
 - or
 - the n-th measurement to be recorded (n = 1 to 10⁵)
- **Stop Saving after...** Define when the sequential saving shall be terminated:
 - after reaching a certain file size (1 to 100 MB)

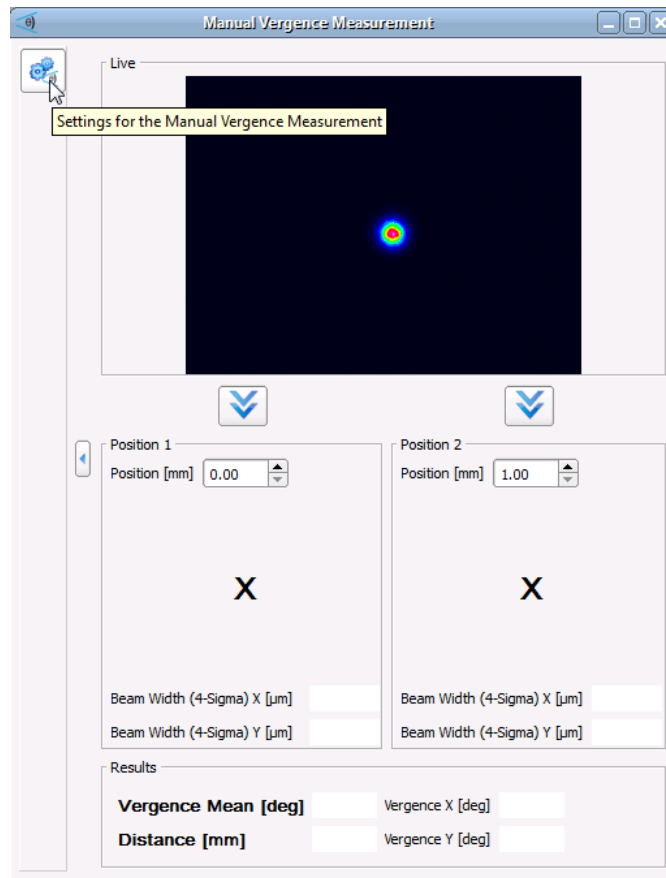

5.4.6.6 Manual Vergence Measurement

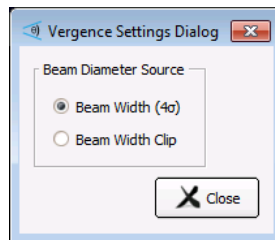

Vergence refers to the divergence or convergence angle of a light beam. The manual vergence measurement allows this angle to be measured using a simple mechanical setup. The Beam Profiler is mounted so that it can slide along the beam propagation trace. This can be done using, for example, a Thorlabs [M2 translation stage](#) or a Thorlabs [RLA Series](#) of dovetail optical rails in combination with a [RC series](#) rail carrier and a post.

Open the Manual Vergence Measurement Window either by selecting the appropriate item from the Menu bar (Windows → Manual Vergence Measurement) or simply by clicking the  icon:



1. Click the  icon in the left upper corner to open "Settings for the Manual Vergence Measurements". Select the beam diameter calculation method. Measure the distance between the light source and the front plane of the Beam Profiler and enter this value to the box "Position 1" in millimeters and click the .



2. The software calculates the beam width at Position 1.

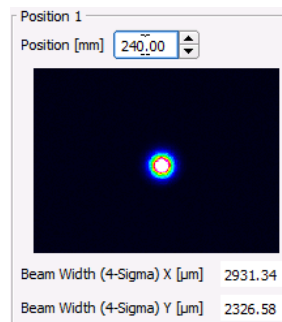

3. Move the Beam Profiler, measure the distance again, enter the new distance into the box "Position 2" and press the 2nd  icon.
4. The beam width at Position 2 is calculated and based on the entered distance change, the vergence angle in X and Y axes is displayed.

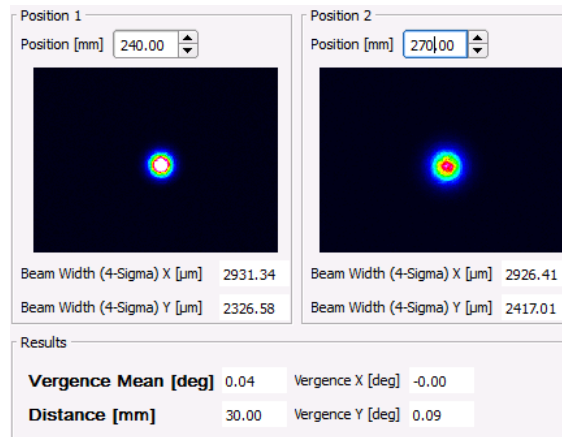

Note

The accuracy of the entered distance between the two positions (shift) of the Beam Profiler is significant for vergence measurement accuracy.

Hint

If you are using the Beam Profiler together with a M2MS Extension Set, the Manual Vergence measurement is even more simple:

- Remove the focusing lens from the system.
- Feed the laser beam into the M2MS-BC207 and BC210C Series input aperture and align it.
- Open in the Beam Settings panel the [Translation Stage Control](#)  topic.
- Use the stage slider to set 0 and 200 mm positions and proceed as described above.

5.4.6.7 Tuning View

The Tuning View child window allows selectable values to be displayed in an analog way, which can be helpful for adjusting the optical setup.

Select from the Menu bar (Windows -> Tuning View) or simply click the  icon. The tuning view can display either two needle scales or 4 bar graphs. Each scale or graph can be assigned to one of the following parameters:

- Sensor Saturation
- Total Power
- Ellipticity
- Beam Width 4σ (X)
- Beam Width 4σ (Y)
- Peak Position X
- Peak Position Y
- Centroid Position X
- Centroid Position Y
- Ellipse Diameter min.
- Ellipse Diameter max.
- Beam Width Clip X
- Beam Width Clip Y

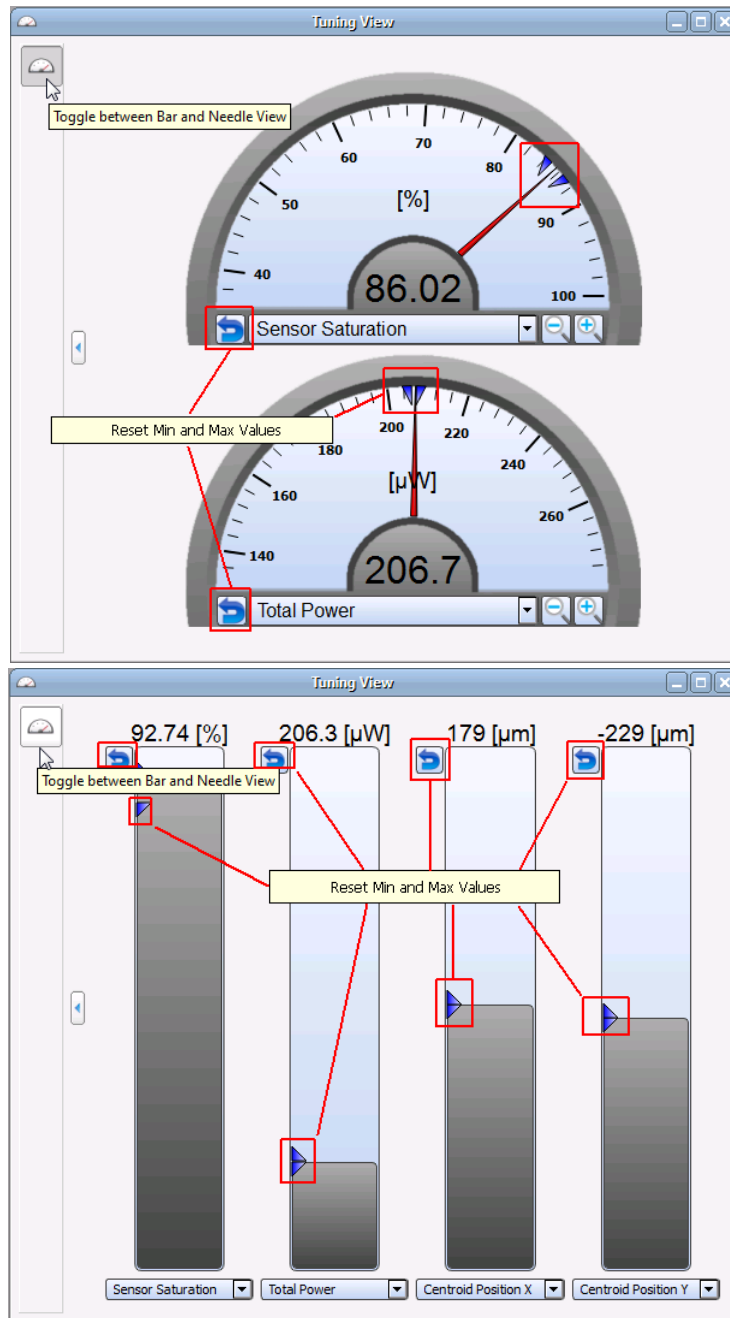

On the scales, the observed minimum and maximum values are shown as blue triangles. They can be reset using the  buttons marked above.

5.4.6.8 Beam Overlapping

The Beam Overlapping tool is useful to adjust the location of a light beam. For example, two sources can be adjusted in such way that their spots overlap at a certain location and are concentric.

Select from the Menu bar (Windows -> Beam Overlapping) or simply click the  icon.

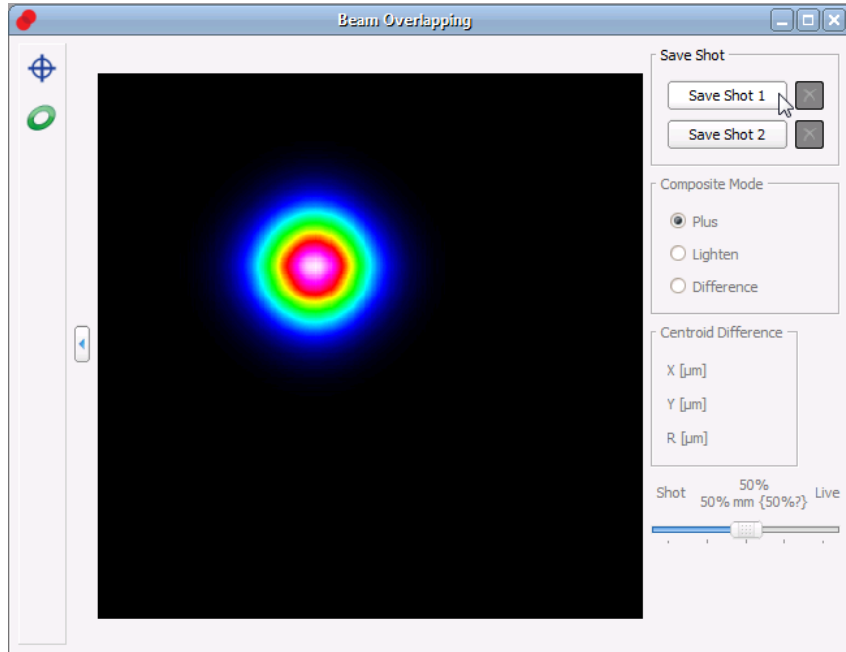

Take a snapshot of the reference position by clicking to the button "Save Shot 1" or "Save Shot 2". The software instantly starts to overlay the live image from the Beam Profiler with the captured snapshot. The overlay method can be selected in the box "Composite Mode":

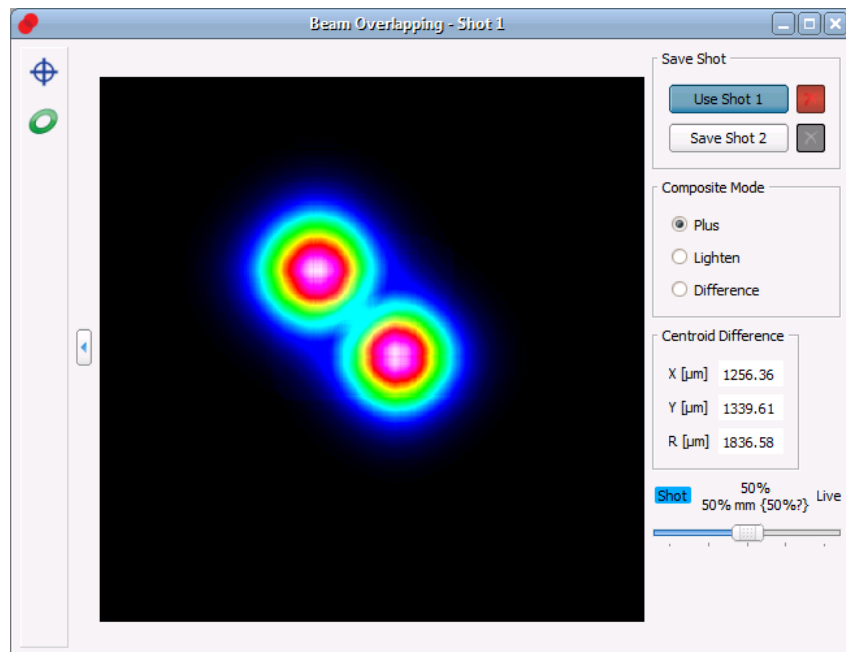

Overlay "Plus"

In "Plus" mode the intensities of the snap shot and the live image are added. This eases the adjustment particularly of regions with lower intensity.

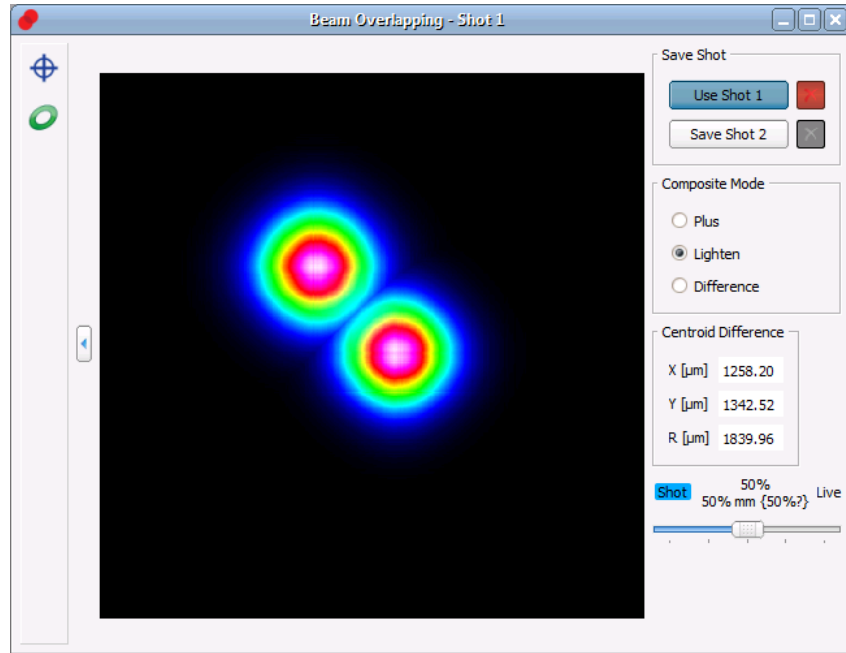

Overlay "Lighten"

In "Lighten" mode, within the overlapping region only the "pixel" with higher intensity will be displayed; the intensities of the snapshot and the current beam are not added.

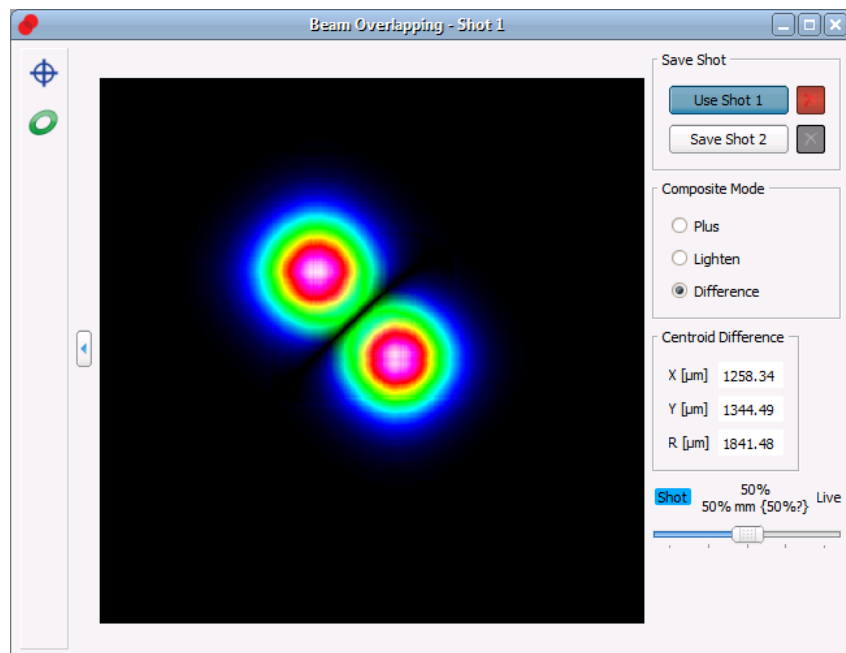

Overlay "Difference"

Finally, in the "Difference" mode, the intensities are subtracted. The more regions appear black within the overlay, the better the live image fits to the snapshot.

The centroid shift between snapshot and live image is displayed in X and Y axis direction, R is the resulting absolute distance between these centroids.

For improved visualization of the overlay, the intensities of the snapshot and the live image can be weighted in 25% steps (slider).

5.4.6.9 Plots

Thorlabs Beam Software offers several additional plot windows to show the beam behavior:

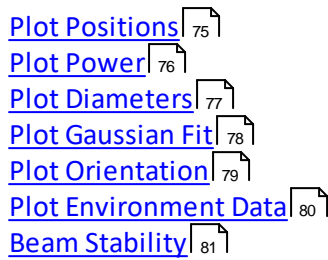



All plot windows are accessible via the "**Windows**" menu, while **Plot Positions**, **Plot Power** and **Beam Stability** also have buttons in the toolbar. The diagrams can be cleared using the "Clear Windows" command (Menu Bar -> Control or  button).

Convenient view functions allow a detailed analysis of the parameter's behavior over time.

- **Display / Hide** a certain parameter: Appropriate buttons are located above the diagrams.
- **Zoom Out**: Press and hold left mouse button and mark the desired diagram area.
- **Undo Zoom**: Right click on the diagram to reproduce the previous zoom status.
- **Zooming Diagram Axes**



Move the mouse cursor over an edge of the vertical or horizontal scroll bar slider. The cursor changes to  or . Press and hold left mouse button and move the mouse. This will zoom in on the appropriate part of the diagram axis. Return to default view by right clicking to the diagram.

- **Panning the Diagram Axes**



Move the mouse pointer over the center of the vertical or horizontal scroll bar slider and press left mouse button. Now the slider can be moved to pan (shift) across the diagram. Return to default view using the Zoom Home button.

- **Autoscale**: This button in the left toolbar returns the diagram to default view (auto scaled).
- **Cursor Mode**: If the mouse position is near to the vertical cursor line, the mouse cursor changes to . The cursor line can be moved with the left mouse button pressed to a position inside the diagram. The current values at the cursor position are shown in a rectangle next to the cursor in the colors of the plotted curve.





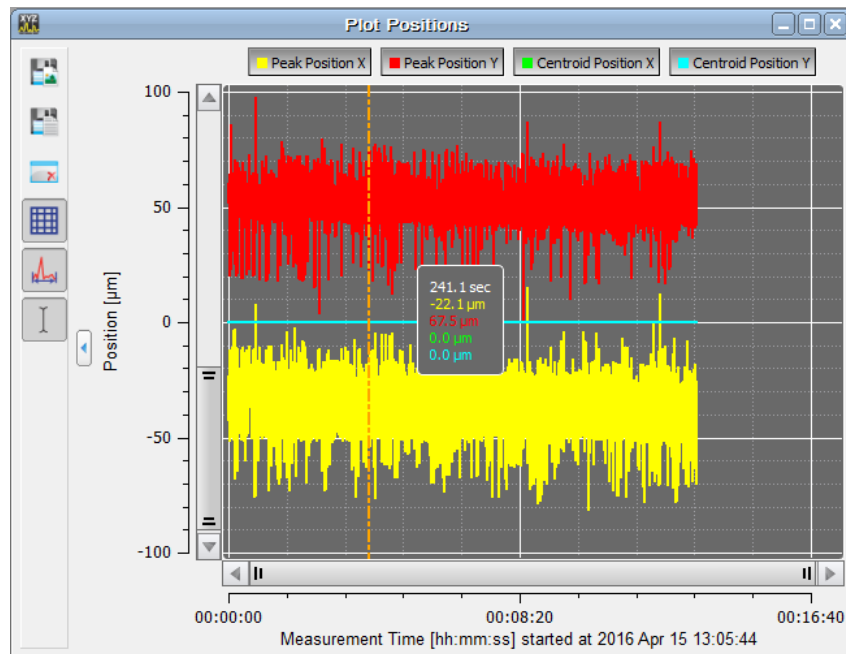

The individual plot windows are explained in detail in the next sections.

5.4.6.9.1 Plot Positions

Toolbar: , Menu bar: Windows -> Plot Positions



The positions of X and Y peak and of X and Y centroid positions can be displayed vs. time.

Toolbar Icon	Associated Action
	Save Diagram or Image: Opens a dialog box to specify the properties of the saved diagram or image.
	Save Data: Opens a dialog box to specify the properties of the saved calculation data
	Clear all plots
	Show or Hide the grid in the diagram:
	Autoscale ON/OFF
	Show or hide the cursor

5.4.6.9.2 Plot Power



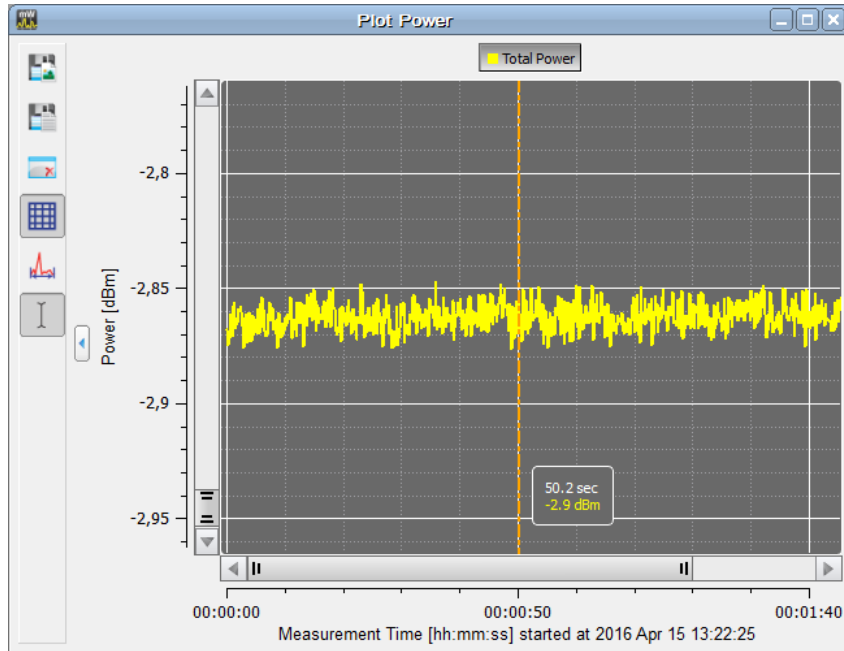



Toolbar: , Menu bar: Windows -> Plot Power



The total power measured by the Beam Profiler vs. time can be displayed.

Note

The power indication of Thorlabs Beam Profiler instruments is not calibrated vs. wavelength, it is based on a typical responsivity curve of the used sensor and the manually entered wavelength (see [Optical Setup / Wavelength](#) ³⁸)

Toolbar Icon	Associated Action
	Save Diagram or Image: Opens a dialog box to specify the properties of the saved diagram or image.
	Save Data: Opens a dialog box to specify the properties of the saved calculation data.
	Clear all plots
	Show or Hide the grid in the diagram:
	Autoscale ON/OFF
	Show or hide the cursor

5.4.6.9.3 Plot Diameters

Menu bar: Windows -> Plot Beam Diameters

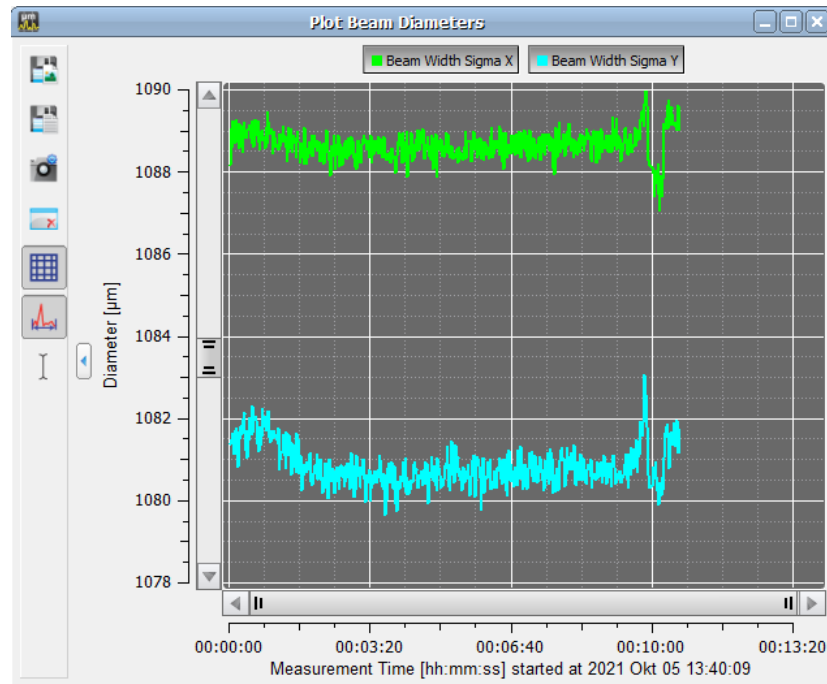





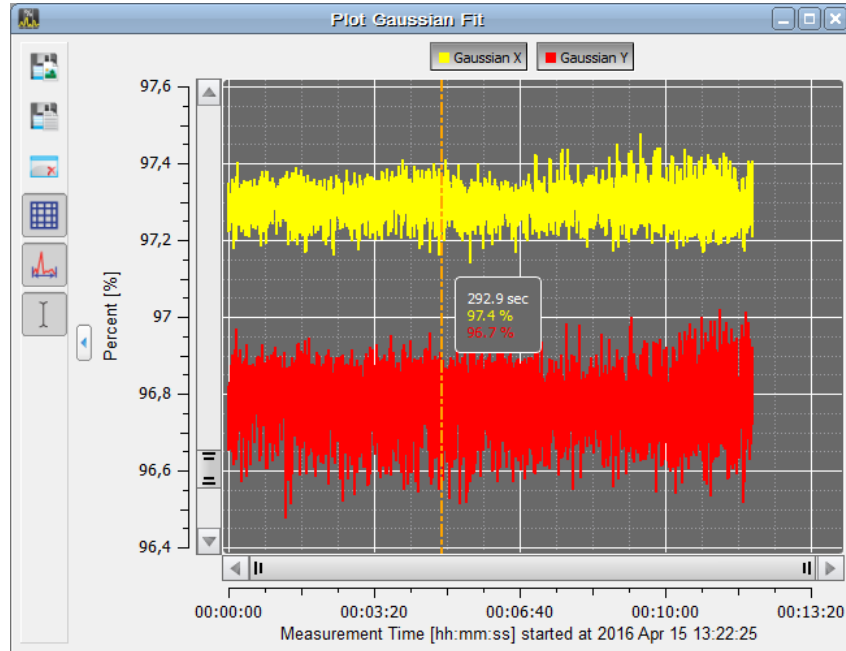

The Plot Diameters window displays the beam diameter over time as the user adjusts settings. This allows to easily monitor the behavior of the beam diameter.

5.4.6.9.4 Plot Gaussian Fit

Menu bar: Windows -> Plot Gaussian Fit



This window plots the Gaussian Intensity value (see [Calculation Results](#)⁶⁴) which shows the coefficient of determination of the fit.





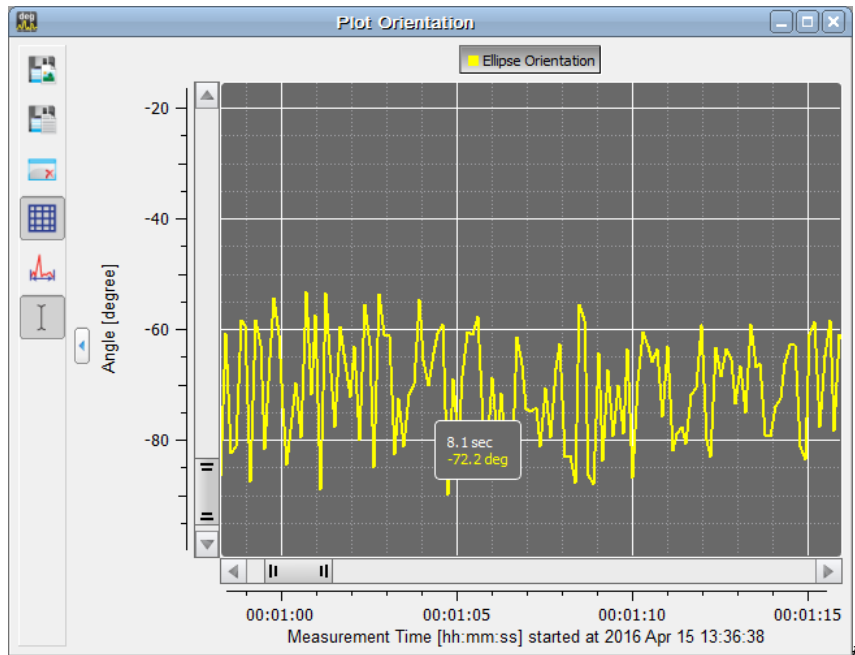

Toolbar Icon	Associated Action
	Save Diagram or Image: Opens a dialog box to specify the properties of the saved diagram or image.
	Save Data: Opens a dialog box to specify the properties of the saved calculation data
	Clear all plots
	Show or Hide the grid in the diagram:
	Autoscale ON/OFF
	Show or hide the cursor

5.4.6.9.5 Plot Orientation

Menu bar: Windows -> Plot Orientation



This window plots the orientation (in degrees) of the ellipse, see [Calculation Results](#) ⁶⁴.





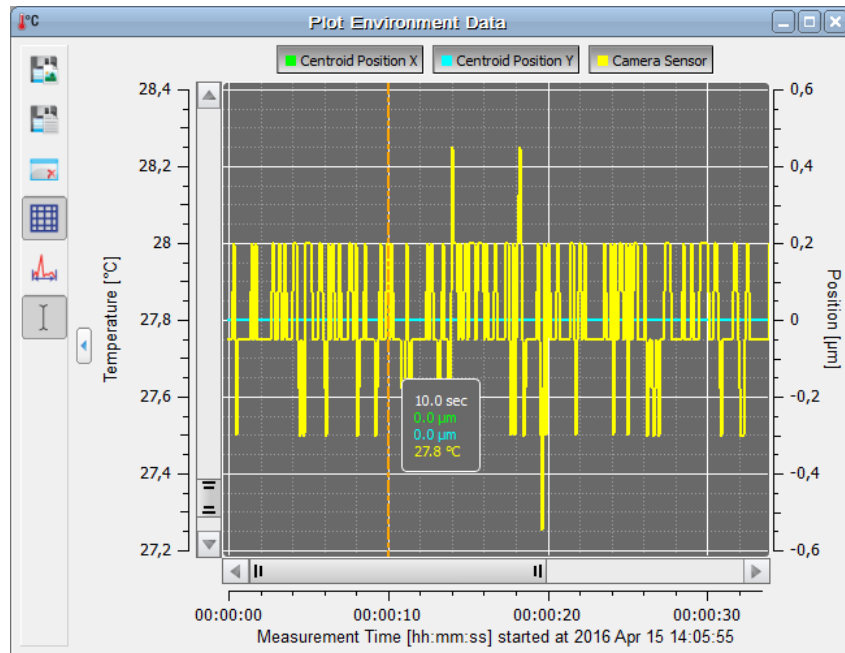

Toolbar Icon	Associated Action
	Save Diagram or Image: Opens a dialog box to specify the properties of the saved diagram or image.
	Save Data: Opens a dialog box to specify the properties of the saved calculation data
	Clear all plots
	Show or Hide the grid in the diagram:
	Autoscale ON/OFF
	Show or hide the cursor

5.4.6.9.6 Plot Environment Data

In this window the position of the X and Y centroids can be logged together with the reading of the camera's internal temperature sensor vs. time.



The temperature axis is located to the left (yellow curve), the centroid position axis (blue and green curves) is shown to the right.

Toolbar Icon	Associated Action
	Save Diagram or Image: Opens a dialog box to specify the properties of the saved diagram or image.
	Save Data: Opens a dialog box to specify the properties of the saved calculation data
	Clear all plots
	Show or Hide the grid in the diagram
	Autoscale ON/OFF
	Show or hide the cursor

5.4.6.9.7 Beam Stability

Toolbar: , Menu bar: Windows → Beam Stability

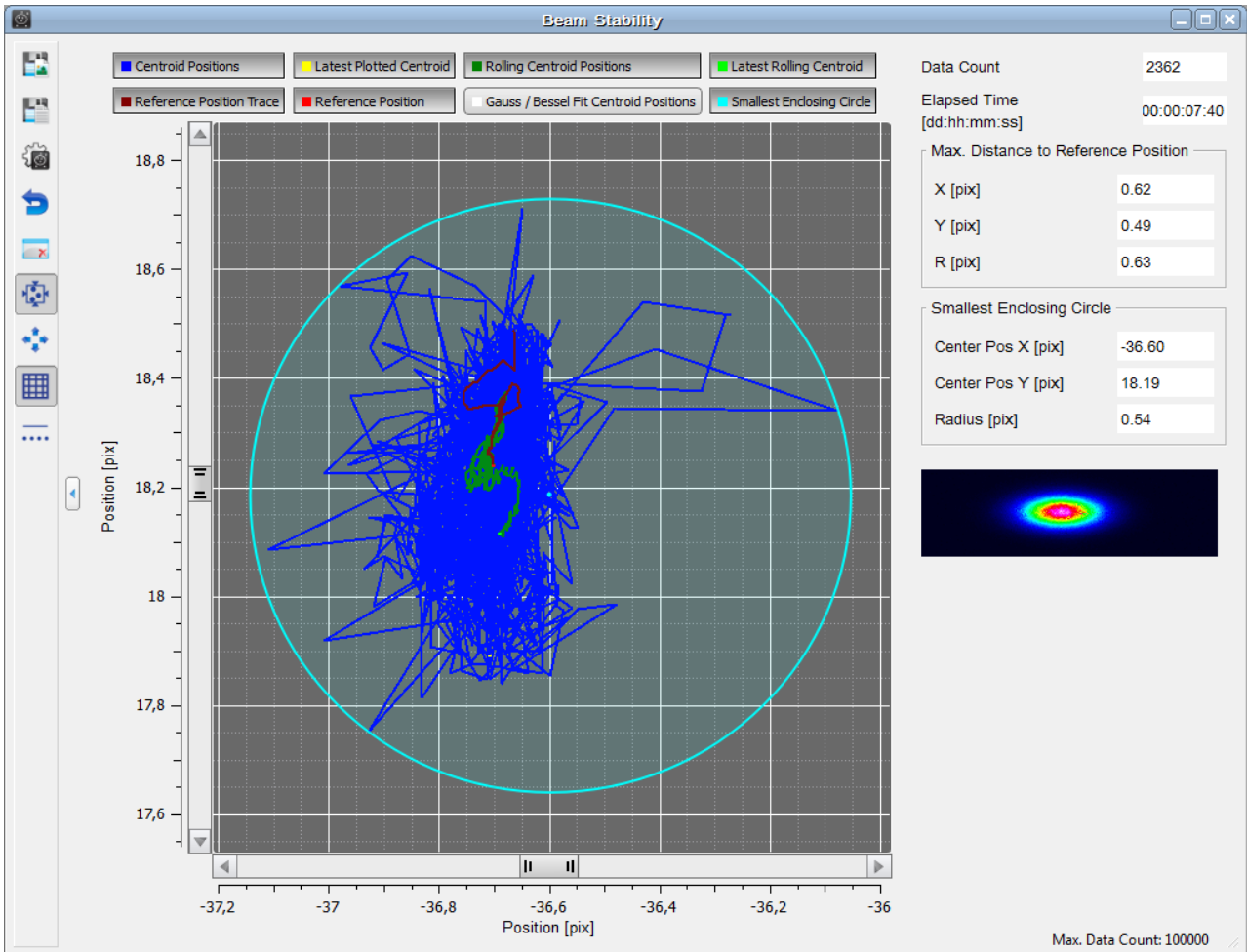

This feature allows the beam stability vs. time to be recorded in a very versatile way. Accumulated data are accessible from the graphic display by enabling several plots:









- | | |
|--|--|
| <input checked="" type="checkbox"/> Centroid Positions | Plots the trace of the centroid positions as a blue line |
| <input checked="" type="checkbox"/> Latest Plotted Centroid | Plots the most recent centroid position as yellow dot |
| <input checked="" type="checkbox"/> Rolling Centroid Positions | Plots the trace of the rolling centroid positions ⁵² as a dark green line |
| <input checked="" type="checkbox"/> Latest Rolling Centroid | Plots the most recent rolling centroid position as a bright green dot |
| <input checked="" type="checkbox"/> Reference Position Trace | Plots the trace of the reference positions ⁸² as dark red line |
| <input checked="" type="checkbox"/> Reference Position | Plots the reference position as a bright red dot |
| <input type="checkbox"/> Gauss_Bessel Fit Centroid Positions | Plots the Gauss / Bessel fitted centroid positions |
| <input checked="" type="checkbox"/> Smallest Enclosing Circle | Plots the smallest enclosing circle around centroid position cloud |
| <input type="checkbox"/> Centroid Positions | Plot disabled |
| <input checked="" type="checkbox"/> Centroid Positions | Plot enabled |

Most of the beam stability characteristics are given in numeric units:

Data Count: The actual count of displayed measurement results.

Elapsed Time: Time since last start of stability measurement

Max. Distance to Reference Position of the centroid positions is given in distance (X), distance (Y) and as radial distance (R). The reference position can be defined in the Settings Dialog (see below the [table](#)⁸²) as either the oldest centroid position or the center of the centroid positions data cloud.

Toolbar Icon	Associated Action
	Save Diagram or Image: Opens a dialog box to specify the properties of the saved diagram or image.
	Save Data: Opens a dialog box to specify the properties of the saved calculation data
	Shows the Settings Dialog (see below)
	Reset Data: Clears Beam Stability data only
	Stops and restarts the measurements, clears all accumulated plot data
	Sets the zoom factor so that all data points are located within the diagram area
	Zoom out to the entire sensor area
	Show or Hide the grid in the diagram:
	Display results as dots or wired

Settings Dialog

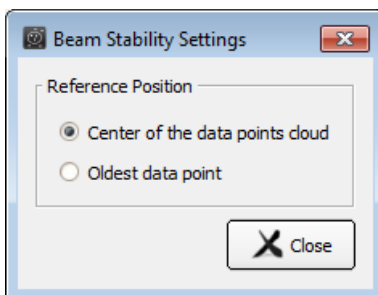

Reference Position: Reference for calculation of beam stability. Can be set to the center of the data cloud or to the oldest displayed data point.

Note

The maximum number of data points to be displayed, the handling of data points after reaching the maximum and the time interval between two displayed data points is set in the menu [Beam Settings / Plot over Time Parameter](#)⁵⁴.

5.5 Measurement with the Beam Profiler

To achieve correct and reliable measurement results, it is recommended that these basic guidelines are followed.

1. Follow the instructions described in [Setup BC207 Series](#)^[16] and [BC210C Series](#)^[17].
2. In the Beam Software:
 - a. Enter the correct [operating wavelength](#)^[38].
 - b. Enter the [attenuation](#)^[39] of the chosen ND filter.
 - c. Perform the [Ambient Light Correction](#)^[40] in case of weak light sources compared to the ambient power level.
 - d. Perform a [Power Correction](#)^[39]

Software Performance Optimization

As soon as a BC207 and BC210C Series device is selected within the "Device Selection" panel, the measurement starts in the continuous mode. It may be advantageous to stop the continuous measurement for a detailed analysis of a beam profile captured with the last image. Also, user interactions with the GUI will work more fluently when the continuous flow of image data is stopped.

Measurement speed of the Camera Beam Profiler depends on various device settings like binning, image resolution (ROI) and the selected exposure time. Also the number of open child windows used to visualize the measured results and the number of activated numerical parameters to be calculated may reduce the available display update rate, depending on the performance of your PC.

Note

For accurate measurement results (power values, M² results) the correct wavelength must be entered. Thorlabs Beam Profiler instruments are not calibrated for power with respect to the wavelength. The power calculation is based on a typical responsivity curve of the used sensor and manually entered wavelength (see [Beam Settings / Optical Setup](#)^[38]).

5.5.1 Operating the Instrument

Be sure that the Camera Beam Profiler is connected to the PC and the driver is installed properly as described in the chapter Connection to the PC.

At the initial program start, the GUI opens and displays the [Beam Settings](#)^[36] panel, the [Calculation Results](#)^[64], [2D](#)^[58] Projection and [3D Profile](#)^[61]. [Child windows](#)^[57] can be opened and closed via the entries in the menu "Window" or via the symbols in the toolbar of the main window. The activated windows can be sized and arranged as desired.

The recognized Beam Profiler will be connected automatically, and the continuous image acquisition starts.

If more than one device was recognized during the initial application start, the first recognized device will be connected and started. Please see section [Start the Application](#)^[26] for details on how to select a different device.

Verify the settings in the section [Optical Setup](#)^[38] if you have started the Beam Software for the first time. For more details on the hardware settings please see the section [Camera Beam Profiler Parameter](#)^[43].

Note

The configuration of child windows is saved when the BEAM software is closed. On the next software instance, the BEAM software is next opened, these windows and their last positions and appearances

are restored. Also, the most recent device selection will be restored when restarting the BEAM application, together with the most recent settings that were made in the settings panel.

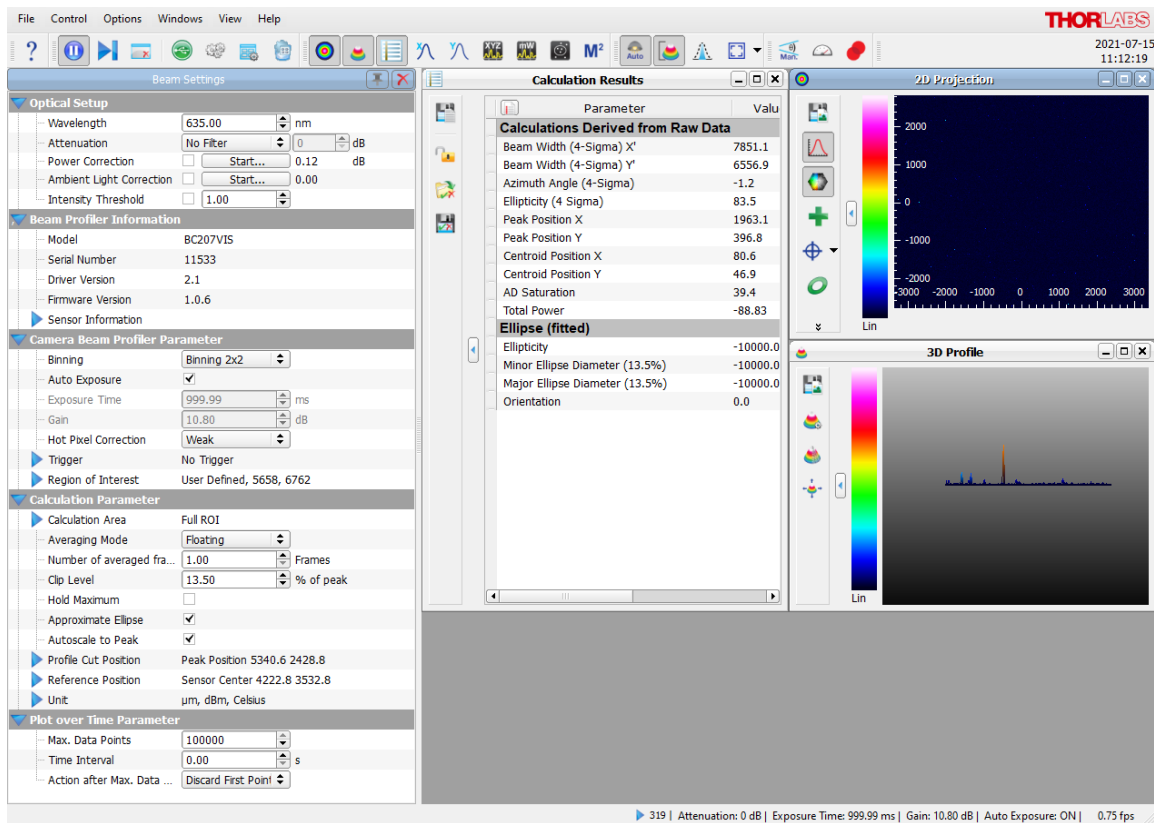

The child window [2D Projection](#)^[58] shows the measured intensity distribution across the sensor area in gray or color scale whereas the [3D Profile](#)^[61] is plots the beam intensity with respect to the 3rd dimension (Z scale). Numerical calculation results are displayed in the appropriate [Calculation Results](#)^[64] window. The parameters to be calculated can be selected by clicking the  icon in left upper corner the [Calculation Results](#)^[64] window.

All contents of the child windows including available options are explained in chapter [Child Windows](#)^[57].

5.5.2 Pass/Fail Test



The Calculation Results panel includes a pass/fail test for reproducible assessment of light beams.

Parameter	Value	Unit	Test	Min.	Max.
Calculations Derived from Raw Data					
Beam Width (4-Sigma) X	2983.33	µm	Pass	2900.00	3100.00
Beam Width (4-Sigma) Y	3039.07	µm	Pass	2900.00	3100.00
Beam Diameter (4-Sigma)	3010.45	µm		2900.00	3100.00
Peak Position X	-19.53	µm		0.00	0.00
Peak Position Y	53.56	µm		0.00	0.00
Centroid Position X (Reference Position)	0.00	µm		0.00	0.00
Centroid Position Y	0.00	µm		0.00	0.00
AD Saturation	85.71	%	Pass	80.00	95.00
Total Power	0.36	mW	Fail	0.50	0.75
Ellipse (fitted)					
Ellipticity	99.44	%	Pass	95.00	100.00
Minor Ellipse Diameter (13.5%)	2716.25	µm	Pass	2600.00	2800.00
Major Ellipse Diameter (13.5%)	2731.49	µm	Pass	2600.00	2800.00
Eccentricity	10.55	%		0.00	0.00
Orientation	--	deg		0.00	0.00
Profile Measurement					
Beam Width Clip X (13.5%)	2689.34	µm	Pass	2600.00	2800.00
Beam Width Clip Y (13.5%)	2699.78	µm	Pass	2600.00	2800.00
Fit Measurement					
Gaussian Intensity X	97.37	%		0.00	0.00
Gaussian Intensity Y	96.98	%		0.00	0.00
Gaussian Diameter X	2527.47	µm		0.00	0.00
Gaussian Diameter Y	2505.24	µm		0.00	0.00
Bessel Intensity X	93.00	%		0.00	0.00
Bessel Intensity Y	92.52	%		0.00	0.00
Environment Parameter					
Camera Temperature	24.25	°C	Fail	22.00	24.00

For each parameter a minimum and / or maximum can be set as criteria.

Pass / fail test criteria can be set to "not below minimum", "not above maximum" by setting the check at Min. or Max., or "between minimum and maximum" by checking the appropriate boxes both, the **Min.** and **Max.** columns.

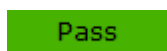
Test results will be displayed in the column **Test** only for those parameters that are selected as test criteria:

-  The selected test criteria was fulfilled; test passed.
-  The test criteria **Min.** was underrun; test failed
-  The test criteria **Max.** was exceeded; test failed





Note

As per definition, the beam ellipse has a major and a minor axis. For a pass / fail test, a minimum and maximum value can be entered in the fields for minor and major ellipse diameter. In the example given above, the "pass" ranges are:

- Minor axis diameter must be between **Min.** = 2600 and **Max.** = 2800 µm
- Major axis diameter must be between **Min.** = 2600 and **Max.** = 2800 µm

The test is passed only if both conditions are fulfilled.

Handling Pass / Fail Test Settings and Results

Toolbar Symbol	Associated Action
	Save Calculation Results
	Lock / Unlock Test Parameters
	Load Test Parameter Configuration
	Save Test Parameter Configuration

Save Calculations opens a dialog box to enter file properties (name, format, comments). For details please see the [Calculation Results](#) section.

Lock By default, pass/fail test parameters are unlocked. They can be locked in order to prevent manipulation of margins and parameters included in pass/fail test. Optionally, the lock can be secured by entering a password.

Note

A password can be entered only once and cannot be changed! In case of troubles, please contact [Thorlabs](#) for a solution.

Load / Save Test Parameter Configuration.

The **Load** and **Save** buttons in the **Calculation Results** toolbar allow you to load and save the configuration of the pass/fail test.

In order to reconstruct a pass/fail test configuration automatically with the next session, save the parameter to a test parameter configuration file. This file will be loaded with the next start of the application. If more than one configuration file is saved, the most recently saved file will be loaded automatically.

To load a test parameter from a file click to the "Load Test Parameter" button and select the test parameter configuration file.

5.5.3 Save Measurement Results

In addition to allowing the [Calculation Results](#)⁶⁶ to be saved, the Beam Software will:

- [Export Device Data](#)⁸⁷
- [Print Windows](#)⁹⁰
- [Save a Test Protocol](#)⁹¹

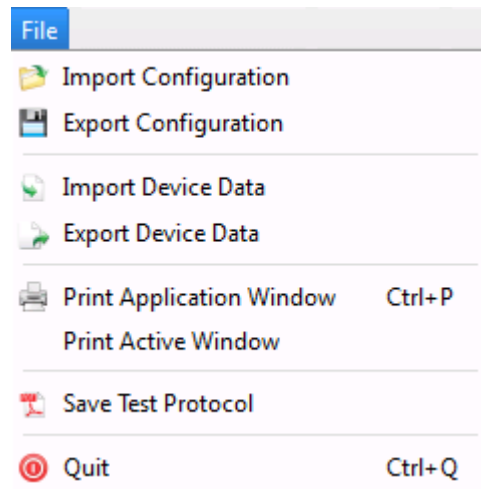

5.5.3.1 Export Device Data

To export data to a delimiter separated text document or an image, select "File → Export Device Data ..." from the Menu.

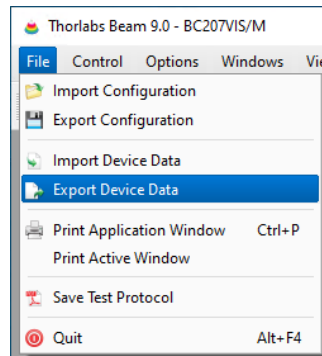

A dialog opens and asks for the type of file and the path where to save the file.

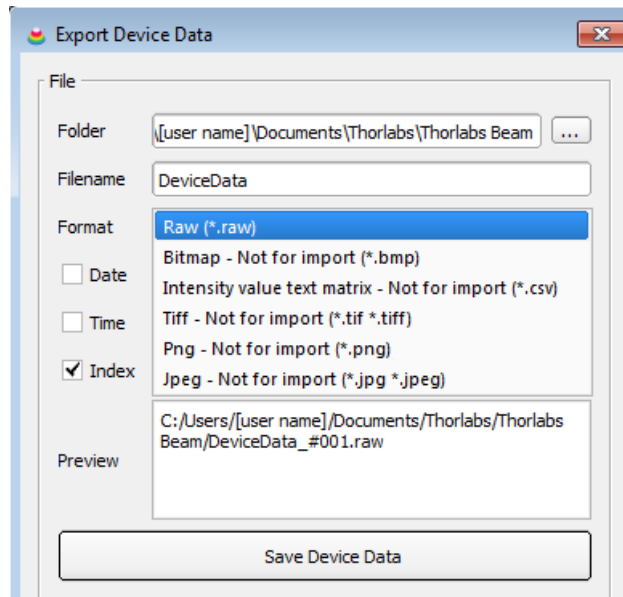

Select the desired path and file name and choose the export format.

- *.raw** is the true image from the camera (intensity value per pixel), with an additional header, including information on pixel pitch and base line. The resolution of the raw data equals to the resolution of the retrieved camera image, i.e., 12 bit. Raw data can be reloaded into the Beam Software and allow to reconstruct the exact image with exception of the total power, because the exposure time cannot be saved within a *.raw file. Raw data format cannot be used for import to standard Windows applications.
- *.bmp** is the standard uncompressed RGB 24bit bitmap format. Therefore, the retrieved camera data are reduced to a 8 bit resolution and saved to the three color channels. This is necessary to achieve the compatibility of the exported image with the standard and thus, to make it readable by standard picture viewers. *.bmp files can be imported by the Beam Software, as this is an uncompressed image format,.
- *.tiff** For export to the TIFF format, the camera image is reduced, similar to the *.bmp, to 8bit and saved to the RGB channels, resulting in a 24 bit image. TIFF images are loss-free compressed.
- *.png** The PNG format is based on a loss-free compression. PNG uses four channels - RGB and the alpha channel that comprises the transparency information (here: white =255 for each pixel). For this reason, PNG are compressed 32 bit images.
- *.jpg** JPEG images are lossly compressed 24bit images. The reduced to a 8 bit resolution camera image is saved to RGB channels and subjected to a memory saving compression.

Note

Compressed images cannot be imported by the Beam Software.

Intensity Value Text Matrix

This is a CSV (comma separated values) file format. The comment "Not for import" is related only to importing into the Beam Software: A data file cannot be imported in order to reconstruct a beam profile.

Intensity values are saved to a text matrix with a header:

Thorlabs Beam					
Version: 9.0.5612.508					
Date: 15.05.2023					
Time: 13:00:46					
Device: BC207VIS/M					
S/N: 11533					
Resolution: Precise (12 bit)					
Sensor Resolution [pix]: Width: 2448, Height: 2048					
Pixel Size [µm]: Horizontal: 3.45, Vertical: 3.45					
Region of Interest [pix]: Horizontal: 0, Vertical: 0, Width 2448, Height 2048					
Wavelength [nm]: 635					
Attenuation [dB]: 60					
Exposure Time [ms]: 9.994					
Gain: 0					
Base Level [digits]: 32.46					
32	31	32	32	32	32
30	34	32	31	31	32

The 1st value in the 1st line of the matrix represents the intensity of the left upper pixel in the 2D Projection.

Sequential Saving

The export of measurement data described above can be repeated sequentially using the Sequential Saving feature on the bottom of the **Export Device Data** panel. This feature generates one single file per data set, with extending the file name created by appending an incremented index. The start index number can be freely selected between 1 and 10000. With each saved measurement, the index is incremented by 1.

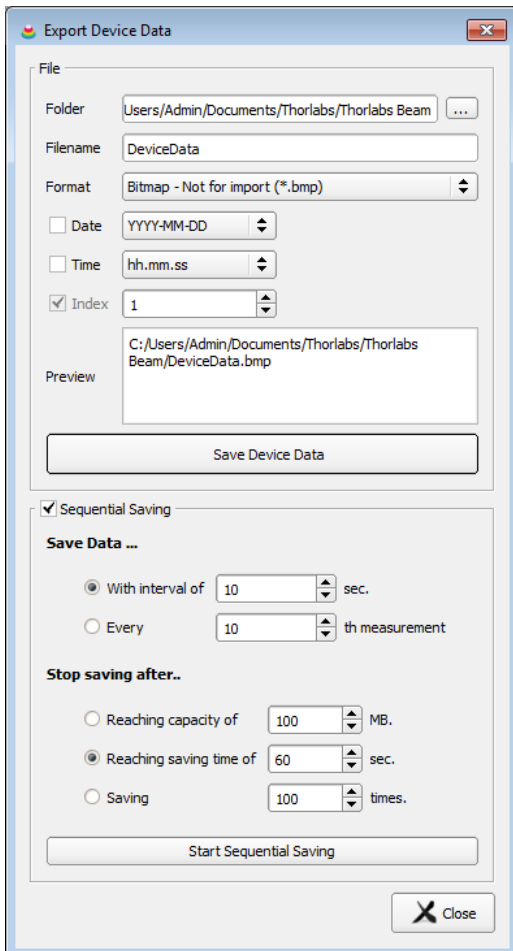

- Select the destination **folder** (see the preview pane).
- Enter the base file name.
- Select the export format [export format](#)⁸⁸.
- Add date and/or time stamp (optional)
- Check the box **Index** and define start index.
- Check the box "**Sequential Saving**"
- Save Data... Select either

→ the time interval between two records (1 to 10^6 sec.)
or

→ the n-th measurement to be recorded ($n = 1$ to 10^5)

- Stop Saving after... Define when the sequential saving shall be terminated:

→ after reaching a certain file size (1 to 100 MB)

→ after reaching a certain recording time (1 to 10^6 sec.)

→ after reaching a certain number of data sets (1 to 10^5)

- Click "Start Sequential Saving"

Attention

For sequential saving, an index value is appended to the selected file name. Make sure, the check box "Index" is marked.

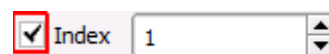

Once the box "**Sequential Saving**" is checked, the indexing is enabled automatically.

5.5.3.2 Print Windows

Select "File → Print Application Window" or "File → Print Active Window" to print screenshots of the appropriate window.

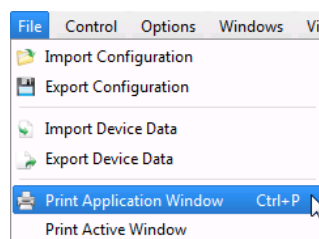

If a PDF creating software is installed as a printer, the screenshot can be printed also as a PDF file.

5.5.3.3 Save Test Protocol

To save a Test Protocol in pdf format select "File → Save Test Protocol".

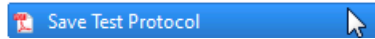

A dialog box opens:

A screenshot of a Windows-style dialog box titled "Test Protocol". The dialog has a title bar with a close button. It contains several sections: "Test Protocol File" with a text field showing a file path and a browse button; "General Information" with fields for "Test Organisation Name", "Test Organisation Address", "Name of Tester", and "User Text"; "Laser Information" with fields for "Laser Type", "Manufacturer", "Manufacturer's Model Designation", and "Serial Number"; and "Test Conditions" with fields for "Laser Wavelength", "Temperature", "Operating Mode", "Laser Parameter", "Mode Structure", "Polarization", and "Environment Conditions". At the bottom right, there are "Save" and "Close" buttons.

Here, additional information can be entered in order to save it together with the test report.

The results of the measurement are saved to a compact test protocol. It contains the Beam Profiler data and settings and [selected numerical calculation results](#)⁶⁴. If the 2D Projection and the 3D Profile windows were activated, these plots will also be included.

5.6 Beam Quality (M^2) Measurement

The **Beam Quality** panel can be opened from the menu bar (Menu **Windows**) or by clicking the M^2 icon in the tool bar.

5.6.1 General

The M^2 value is an important measure of the beam quality. It is widely used in the laser industry as a specification, and its method of measurement is defined in the ISO 11146 standard. It is particularly useful to describe the degree of divergence and the focusability (minimum focus diameter) of a real laser beam.

For more detailed information about Beam Quality, please see section [M² Theory](#)¹⁴³.

Beam Quality

Beam Propagation measurements according to the standard **ISO 11146** describe the beam quality using a single parameter, which is either the **Times-Diffraction-Limit Factor M^2** or the **Beam quality $K = 1/M^2$** (also known as *beam quality factor* or *beam propagation factor*).

Whereas the beam quality K is directly proportional to the quality level ($K=1$ optimal, decreasing K stands for poorer quality), its reciprocal value M^2 ($M^2=1$ optimal, increasing M for poorer quality) is used more often.

Please do not confuse the beam quality ($K \leq 1$) and times-diffraction-limit factor ($M^2 \geq 1$).

Diffraction Limit

Depending on the wavelength λ and beam divergence angle q , the theoretical limit for the minimum beam waist diameter d_0 is called the **diffraction limit**. The beam waist cannot be decreased beyond this value.

M^2 expresses how close the diffraction limit of the analyzed beam is to the diffraction limit of an ideal Gaussian beam. The beam parameter product $d_0 \cdot q$ describes that mathematically. For beams of less quality, the product $d_0 \cdot q$ is increased by the factor M^2 .

$$d_0 \rightarrow M^2 d_0$$

where d_0 is beam waist at the focus and q - the divergence angle.

M^2 is also known as

- the ratio of the waist diameter d_0 of the measured beam to that of an ideal Gaussian beam (TEM_{00}) at the same divergence angle q .
- the ratio of the divergence angle q of the measured beam to that of an ideal Gaussian beam (TEM_{00}) at the same waist diameter d_0 .

Lower beam quality results from laser imperfections like inhomogeneities which lead to appearance of higher transverse modes.

How to Measure Beam Quality

Ideal beam quality ($K=1$, $M^2=1$) with a diffraction limited waist size is possible if only the fundamental mode TEM_{00} (which has an ideal Gaussian shape) exists. The existence of higher modes decrease beam quality which leads to larger waist diameters. Often, such distortions can be easily discovered by looking at the non Gaussian beam profile.

But in many cases, several higher modes are distributed in a way that generate a nearly Gaussian shape but the beam itself suffers from a bad beam quality.

The following example shows a beam with nearly perfect Gaussian shape but having a multi-mode origin leading to bad quality $M^2 = 1.79$.

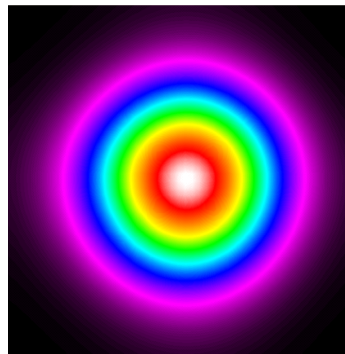

Note

A nearly Gaussian shape is not an indicator of high beam quality! Therefore, a single-shot beam shape measurement from a Beam Profiler does not provide a correct information about the beam quality.

Although a single Beam Profiler result is not a measure of beam quality, the Thorlabs Camera Beam Profiler Series can be used to accurately measure the beam quality. For this purpose, a beam propagation measurement is carried out according to the ISO11146 standard. The key idea is to measure the variation of beam diameter $d(z)$ along the axis of beam propagation z .

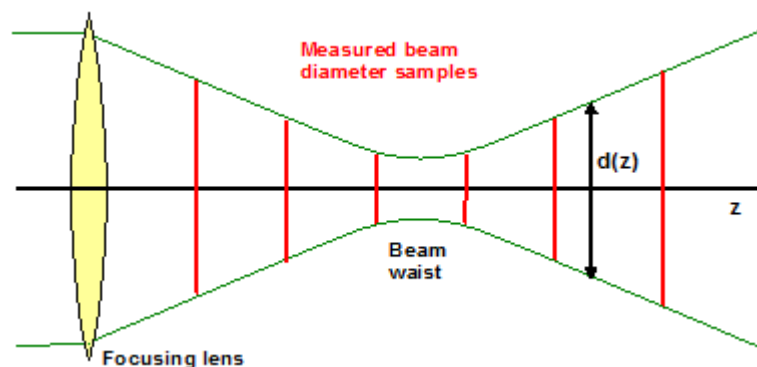

When used with the M2MS measurement extension, the beam diameter and other parameters are measured at several z -positions and stored by the software.

Besides learning the **times-diffraction-limit factor M^2** , the Thorlabs Beam Propagation measurement determines the following parameters of an optical beam:

- beam waist width d_{0x} , d_{0y}
- beam waist z -position z_{0x} , z_{0y}
- Rayleigh range z_{Rx} , z_{Ry}

- divergence angle θ_x, θ_y
- waist asymmetry
- divergence asymmetry
- astigmatism

Note

The Thorlabs Beam Quality measurement tool can handle CW sources and some pulsed sources! For more information about pulsed laser sources read chapter [Trigger](#)⁴⁵.

5.6.2 M2MS Operating Principle

The Thorlabs M2MS M² Measurement System is a compact instrument that includes all components required to measure beam quality:

- ① Beam Profiler such as the BC207 or BC210C Series (Not Shown Below) or Adjustment Laser (not shown below)
- ② Linear Translation Stage Thorlabs DDS100
- ③ Lenses with different AR coatings, suitable for different wavelengths to be analyzed
- ④ Lens centering assembly (X-Y translation mount)
- ⑤ 2 tilted mirrors
- ⑥ Integrated control electronics (translation stage controller, USB 2.0 hub and driver for alignment laser)

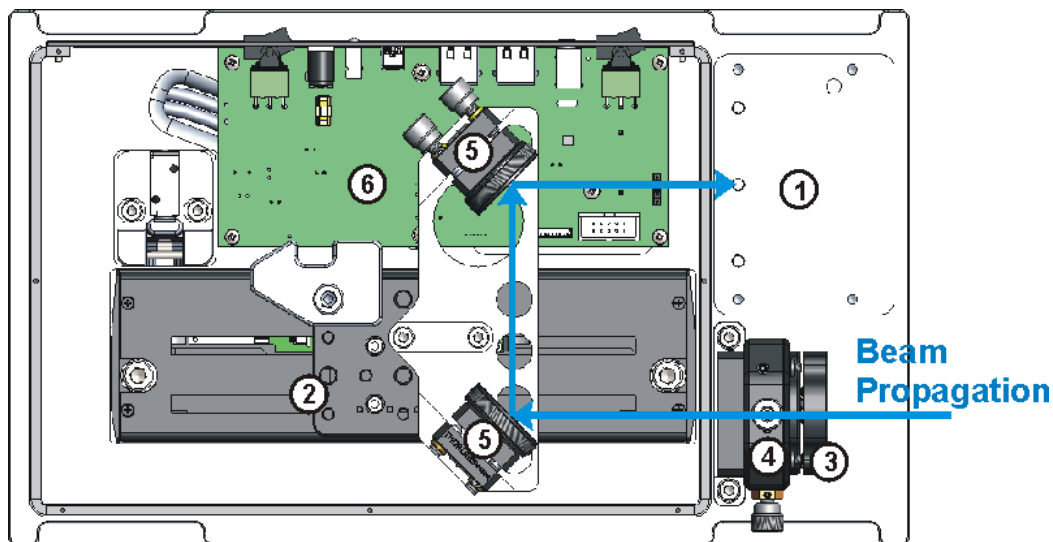

The beam under test enters the the focal lens (3), hits the two tilted mirrors (5) and leaves the enclosure towards the Beam Profiler's input aperture (1). The translation stage is moved stepwise by the control software, and in this way changes the path length between the focal lens and the Beam Profiler. The maximum travel range of the stage (100 mm) is doubled by the use of two mirrors. The resulting path length range is 200 mm. The focal length of the lens is selected in such a way that the beam waist will be close to the middle of the travel range.

During the M² measurement, the stage moves stepwise along the beam propagation direction and at each position the beam geometry is measured. From the results, the software calculates beam parameters and beam quality.

The mirrors are factory aligned; there is no need to re-align them.

For fine beam alignment, an alignment laser is supplied. Please see section [Beam Alignment](#)^[101] for details.

5.6.3 Beam Diameter Requirements

The Beam Quality measurement is based on the determination of the waist diameter of a focused beam and the convergence (divergence) of the beam before (after) the beam waist.

Ideal Gaussian beams have the best focusability, which results in the minimum possible beam diameter and $M^2=1$. The absolute minimum waist diameter increases as the focal length of the lens increases. In other words, for a given focal length, the smaller the waist diameter the closer M^2 is to 1.

The minimum waist diameter increases (at a constant M^2) with the wavelength.

Limitations to the measurement of the beam diameter are given by the capabilities of the Beam Profiler, see [Technical Data](#)^[152]. The initial (unfocused) beam diameter must not exceed the maximum measurable beam diameter, the waist diameter must be greater than the minimum beam diameter. The following diagram illustrates the requirements for the initial beam diameter depending on the wavelength and for $M^2=1$ and $M^2=2$ (lens with a focal length of 250 mm as delivered with the M2MS system):

BC207 and BC210C Series Beam Diameter Requirements

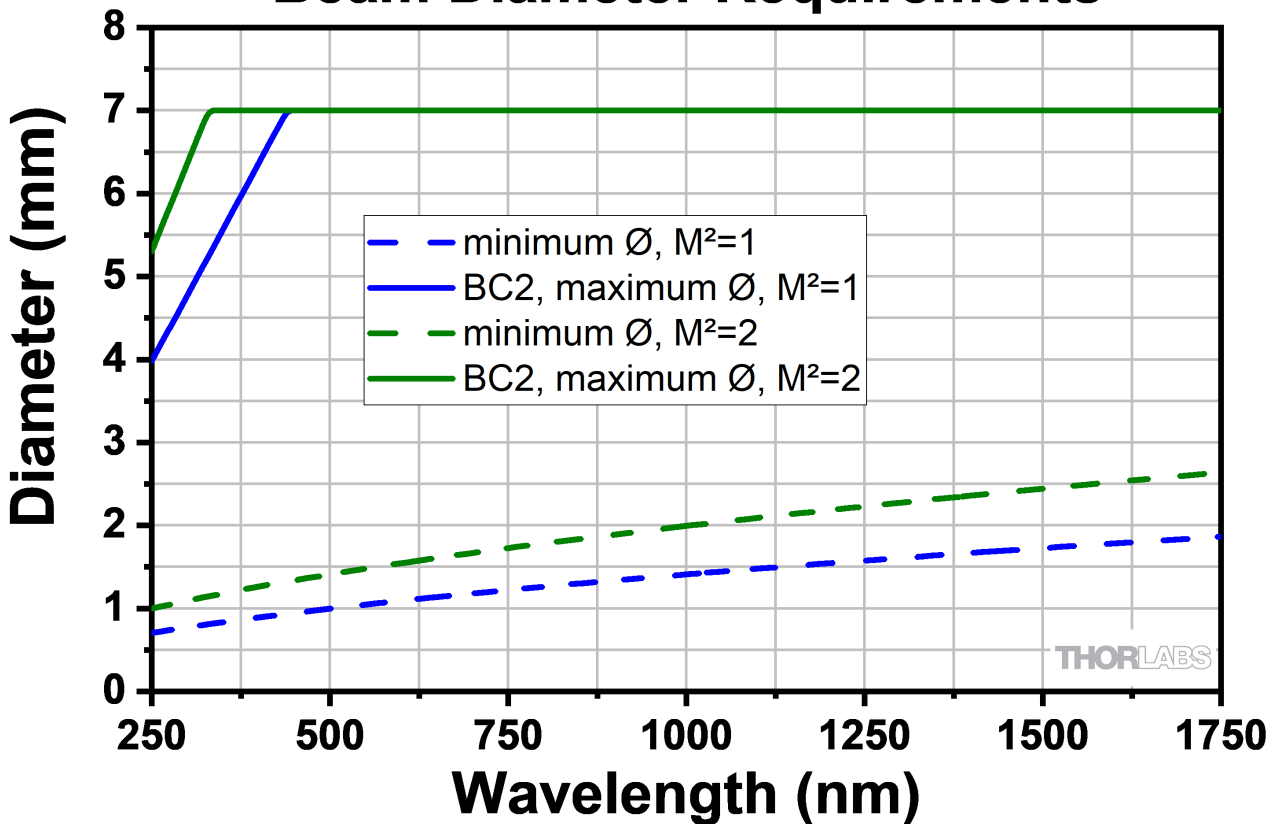

5.6.4 M² Meter Extension Set

The M² Meter Extension Set is an automated stage, compatible with all Thorlabs beam profilers of the BP209, BC207 and BC210C Series as well as the former BC106N Series, to scan through the light beam in the Z-axis for the beam profiler to acquire an M² value. Suitable mounting adapters for the beam profilers of the BC207 Series, BP209 Series and BC210C Series are supplied. Please see the [M2MS website](#) for other adapters and information.



M2MS M² Measurement System Extension Set with adapters for BC207 Series, BC210C Series and BP209 Series as well as the alignment laser.

5.6.5 Setup M2MS

The M2MS Measurement System is factory aligned. The mounting adapter for the Beam Profiler provides a secure and reproducible positioning of the Beam Profiler's input aperture to the M2MS. This eases the mechanical setup.

Note

It is strongly recommended to fix the M2MS properly to the optical table using the four rail clamps that are included in the M2MS Accessory Box. To ensure proper mounting, first remove the rubber feet from the M2MS base plate.

Transportation Lock and Stop Position Latch

In order to avoid transportation damages to the translation stage, it is locked when delivered. This lock must be removed prior to powering-up the stage, and it must be re-installed for transportation. Additionally, the DDS100 stage is fixed at its initial position by a solenoid controlled latch, which is the

left stop in the photo (2). This latch fixes the stage when the power supply is switched off and releases the stage when power is applied.

Removal of the Transportation Lock

1. Remove the 4 screws fixing the top cover using a 0.05" hex key (supplied with the M2MS) and remove the cover.
2. Remove the M4 fixing screw and red stopper (1) using the 3 mm ball driver included with the accessory box. Keep the M4 fixing screw and stopper in a safe place for future usage.

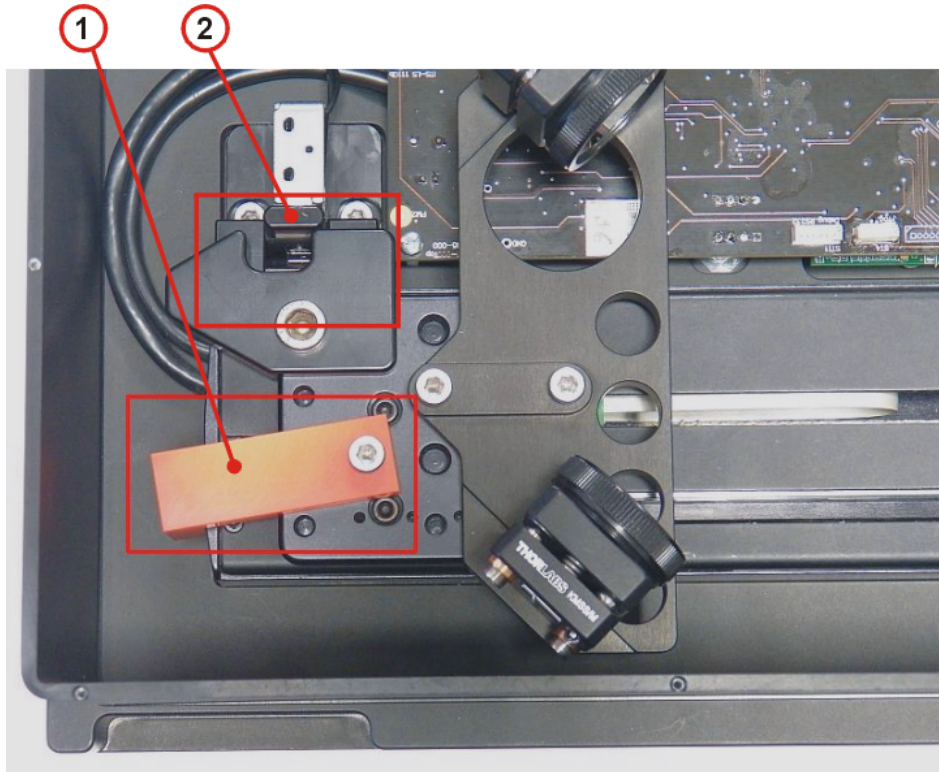

1 - Transportation Lock
2 - Electromagnetic Endpoint Latch

3. Close the M2MS.

Installing the Transportation Lock

1. Switch off the power supply.
2. Remove the 4 screws fixing the top cover using a 0.05" hex key (supplied with the M2MS) and remove the cover.
3. Move the stop latch as indicated in the picture below and place the platform of the stage against the left stop. Then install the transportation lock; do not tighten the fixing screw yet.

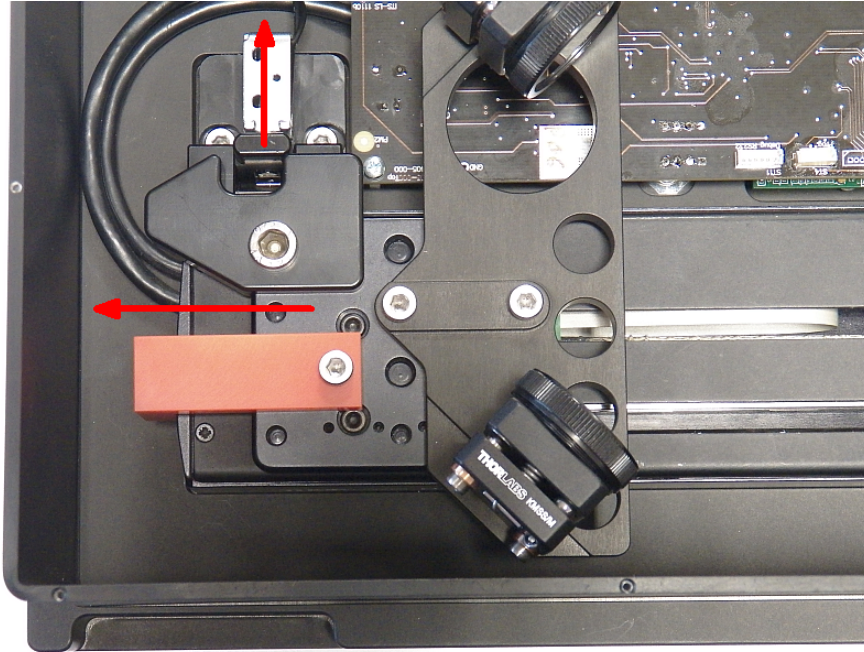

4. Push the platform to the left stop, turn the lock counterclockwise and tighten the fixing screw.

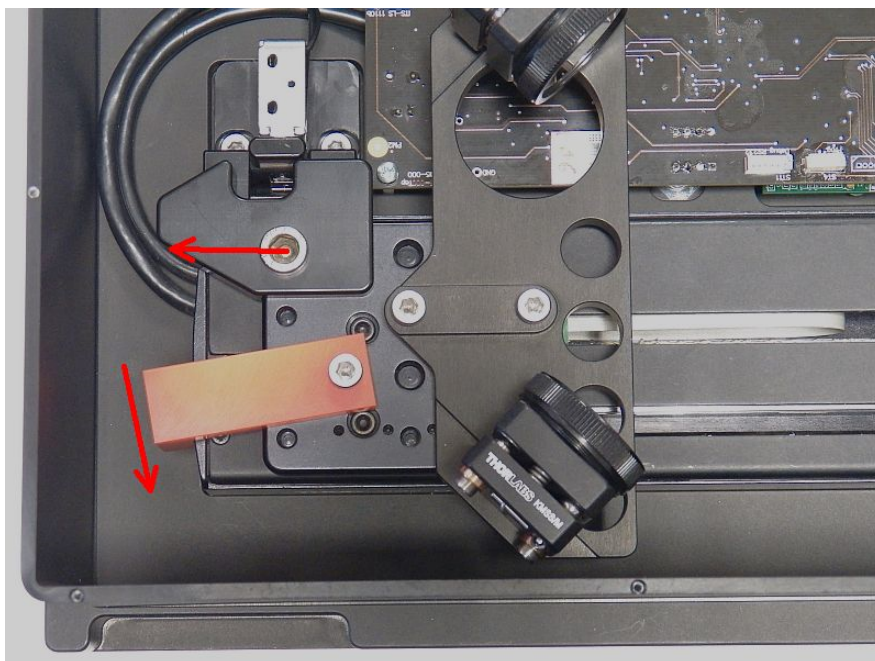

5. Place back the top cover and fix it using the 4 screws. Now, the M2MS is ready for transportation.

5.6.5.1 Mounting the Beam Profiler

Please mount your Beam Profiler as described above in chapter [Mounting BC207 Series on M2MS\(-AL\)](#)¹⁹.

5.6.5.2 Connecting M2MS to the PC

The M2MS comprises integrated control electronics with translation stage controller, a USB 2.0 hub and a current source for the alignment laser.

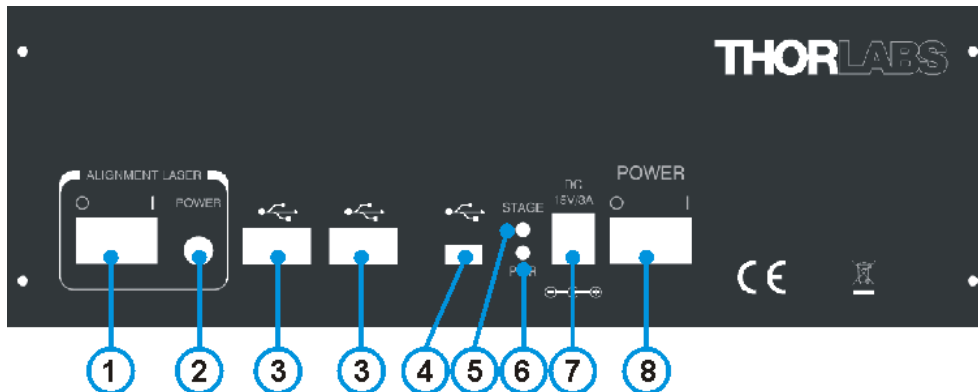

- ① Switch to enable Alignment Laser
- ② Output connector for Alignment Laser
- ③ USB 2.0 hub output ports (to Beam Profiler) (not recommended for BC207 and BC210C as BC207 and BC210C requires USB 3.0)
- ④ USB 2.0 input (from PC)
- ⑤ Yellow indicator "Stage active"
- ⑥ Green indicator "Power On"
- ⑦ DC power supply input
- ⑧ M2MS power switch

Attention!

Prior to connecting the M2MS to the power supply, make sure the [transportation lock is removed](#)^[96]! Otherwise the stage drive may be damaged!

Attention!

It is strongly recommended that only the supplied USB cables are used to connect the Beam Profiler and the control PC to the M2MS.

The use of other than the supplied USB cables may lead to USB connection instabilities.

Attention

Do NOT connect the M2MS to a computer prior to installing the Beam Software!

1. Remove the [transportation lock](#)^[96].
2. Connect AC power to the power supply and its output to the DC jack ([Z](#)^[99]).
3. When using a BP209 Series Slit Beam Profiler, connect the Beam Profiler using the supplied angled USB 2.0 cable to one of the USB hub outputs (3). Please do not connect a BC207 and BC210C Series camera Beam Profiler as they require USB 3.0. Please connect the BC207 and BC210C Series camera Beam Profiler directly to the [PC](#)^[24].
4. Switch the M2MS on (8). The green **Power On** indicator lights up.
5. Connect the M2MS to the PC using the supplied 3 m long USB 2.0 cable; do not start the Beam software yet.

6. The PC's operating system recognizes the connected new hardware and performs the driver installation:
7. Start the Beam Software. It should automatically connect to the Beam Profiler and to the translation stage. This can be seen in the Beam Settings Panel:

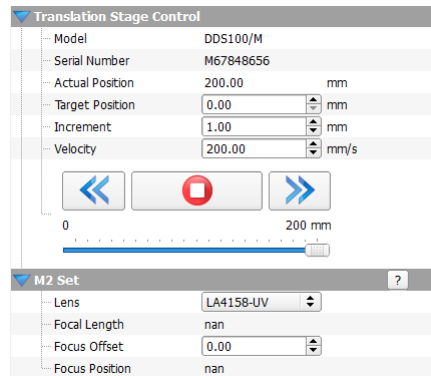

8. Upon starting the Thorlabs Beam Software, the translation stage will be initialized and homed automatically. This means that it is recognized in the tab **Stage Selection** and moves to the 200 mm position in case it is not there yet. This can take a few seconds. The initialization can be forced manually by clicking the "Refresh Stage List" button in the [Device Selection window](#)^[25]. After the stage is identified and its serial number is read from its EEPROM, double click the DDS100(/M) button in the device selection window.

5.6.6 M² Measurement

Prior to starting the Beam Quality measurements with the M2MS and a BC207 and BC210C Series Beam Profiler, the beam of the laser under test needs to be aligned to the M2MS Measurement System. It is important that the beam center hits the center of the Beam Profiler's aperture at every position of the translation stage. Please read the following section carefully and follow the instructions.

Please open the M2 measurement panel via the icon **M²** to arrive at the alignment and measurement GUI.

To prepare for and perform a M2 measurement, please click the M² icon on the left side of the window. The top panel shows the [Alignment](#)^[101] tab, the [M² measurement](#)^[100] tab, and the [Live Adjustment](#)^[128] tab. Please start with the Alignment of your system.

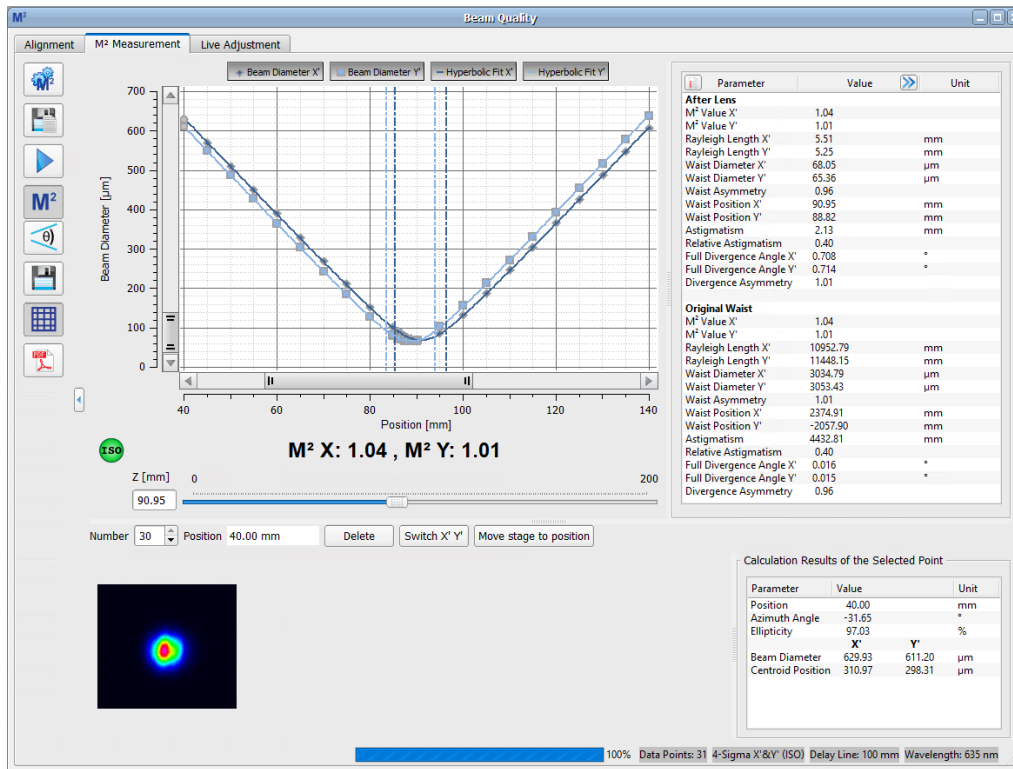

5.6.6.1 Beam Alignment

Why Beam Alignment?

The Beam Profiler has a defined input aperture, so when moving the translation stage it must be ensured that the laser beam remains within the aperture. Ideally, the beam centroid remains centered within the aperture during movement of the stage - this is a precondition for correct beam quality measurements.

All internal parts of the M2MS Measurement System are factory aligned. A beam entering the M2MS exactly parallel to the stage movement direction will remain centered to the Beam Profiler aperture during stage movement. In other words, the beam alignment is dependent only on the position of the light source. In the common case, the light source is a device with open beam output. In order to direct the beam under test into the M2MS, a combination of two adjustable mirrors is required, Thorlabs offers a variety of such items.

The beam alignment is executed in 3 steps, guided by a software wizard:

1. [Coarse Alignment](#)^[101]: Determine the correct location of the Laser Under Test output aperture by means of an auxiliary laser (included).
2. [Beam Alignment](#)^[105] of the Laser Under Test for minimum beam displacement and pointing angle without focusing lens.
3. [Alignment of the Focusing Lens](#)^[109] for minimum beam displacement and pointing angle.

5.6.6.1.1 Coarse Alignment

For a coarse alignment, Thorlabs provides an alignment laser that is included with the accessory box. For this step, the alignment laser is mounted on the M2MS in place of the Beam Profiler as described below. It is mounted and aligned in such way that its output beam enters the M2MS exactly centered in the Beam Profiler's aperture and is parallel to the stage movement direction. The alignment beam is

reverse directed - it virtually exits the Beam Profiler and is redirected by the two mirrors of the stage into the center of the laser source aperture (see the drawing in section [M2MS Operating Principle](#)^[94]).

Warning Be careful when using the Alignment Laser!





- Remove the Beam Profiler together with its mounting adapter from the M2MS base.
- Install the adjustment laser in place of the Beam Profiler and connect its 3.5 mm plug to the [Alignment Laser output \(2\)](#)^[99].
- Make sure the M2MS is switched on and connected to the control PC, the Beam Software is started and the stage has been initialized.
- Remove the focal lens from the magnetic holder.
- Switch on the alignment laser.
- Align your optical system so that the spot of the alignment laser hits the center of your light source.

5.6.6.1.2 Fine Alignment







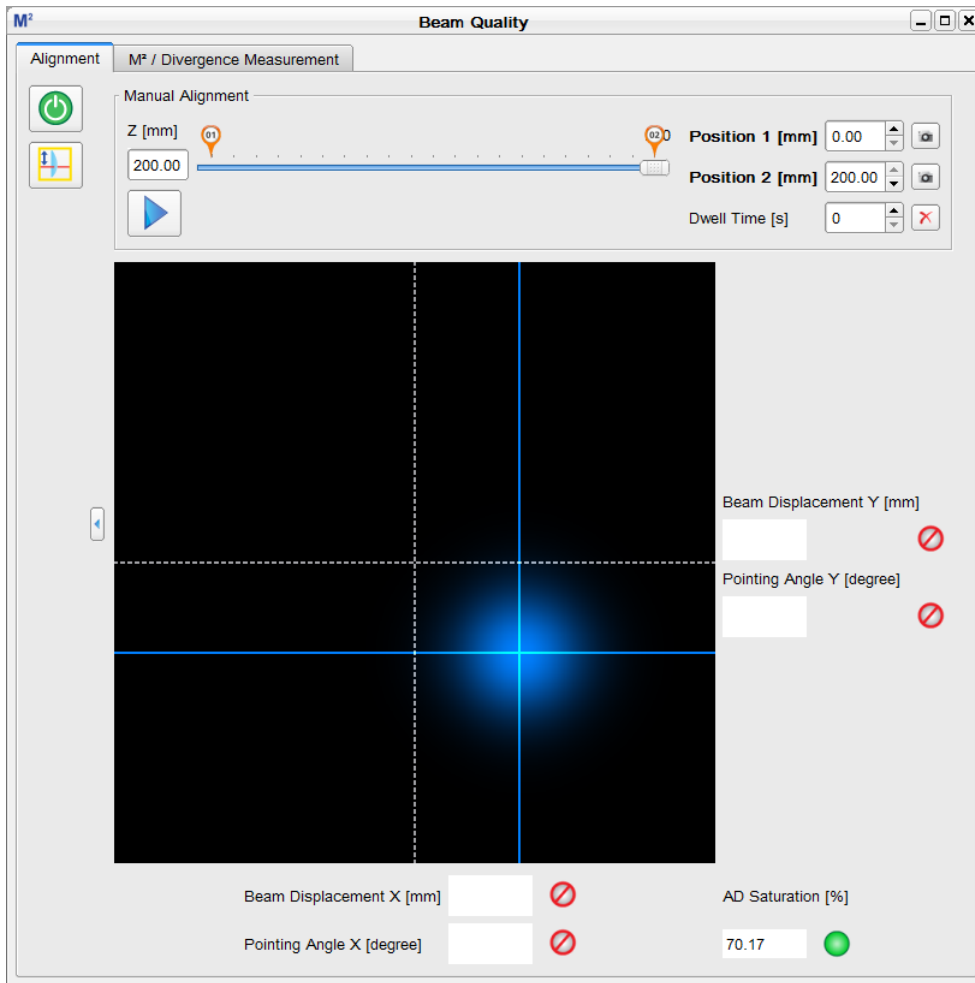



After coarse alignment, the beam under test needs to be fine-adjusted using the **Alignment** feature of the M² measurement panel. This is executed in two steps.

Preparation

- Switch off the alignment laser and replace it with your Beam Profiler.
- Make sure the BC207 or BC210C beam profiler is connected to the PC via the USB3.0 port. When using an older BC106N beam profiler, connect the beam profiler to one of the M2MS USB output ports (see [Connection to the PC](#)^[99] section).
- Remove the focusing lens (see  in the drawing in the [M2MS Operating Principle](#)^[94] section).
- Make sure the BC207 or BC210C Series beam profiler is recognized by the Beam Software (Toolbar  [Device Selection](#)^[100]). If it is not recognized automatically, press the **Refresh Device List**^[25] button.
- Make sure the stage is recognized and initialized. If not, press the [Refresh Stage List button](#)^[100] and after the stage was recognized, double click to the DDS100 button. The stage initializes and moves to the 200 mm position.
- Enable the Laser Under Test.
- Open M² child window either from the menu "Windows" -> "M² Quality Measurement" or by clicking the **M²** button, and switch to the Alignment tab.



Explanation of indicators and icons

	Start the Alignment Wizard ¹⁰⁵
	Start the Focusing Lens Alignment Wizard ¹⁰⁹
Z [mm]	This box shows the actual stage position; after initialization = 200 mm.
Position 1 (2) [mm]	The left and right positions for the stage movement can be entered numerically.
	Markers for left and right positions. Instead of numerical entry of the marker positions, the markers can be moved by drag-and-drop.
	When clicking these capture buttons, the stage moves to the related position, if not there yet, and captures the beam centroid position (amber crosshair). This snapshot will remain until the stage returns to the appropriate position.
	This button starts the stage loop movement mode and the stage moves continuously between positions 1 and 2. A dwell time at the end positions can be entered. During the loop mode, the software automatically captures the beam centroids (yellow cross hair) at the left and right stop.
Dwell Time	Enter the desired time [sec]. Disable the dwelling by clicking to the  icon.
	Centroid crosshair of the actual beam position.
	Crosshair of the sensor center
Beam Displacement	Centroid shift in X (Y) direction between position 2 and 1 [mm]. The box is initially filled after the 2nd capture.
Pointing Angle	The angle [°] in X (Y) direction between the beam axis and the stage movement direction. The box is initially filled after the 2nd capture.
Alignment Success Indicator	<ul style="list-style-type: none">  Alignment not successful  Alignment sufficient for correct Beam Quality Measurement (displacement < 0.65 mm, angle < 0.35°)  Good alignment (displacement < 0.35 mm, angle < 0.15°)
AD Saturation	Displays the current saturation of the Beam Profiler's AD converter. For proper beam alignment function the value must be 50 to 95 %. The green bulb to the right of the numeric field indicates the "GOOD" range.

5.6.6.1.2.1 M² Beam Alignment Wizard

Press the **Start Wizard** button . You will be requested to select whether you want to adjust for M² or Divergence Measurement. Make your choice:

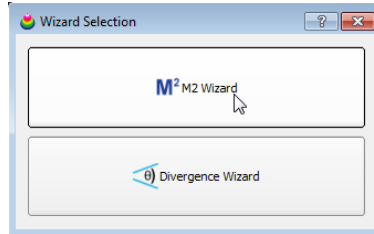

The wizard starts:

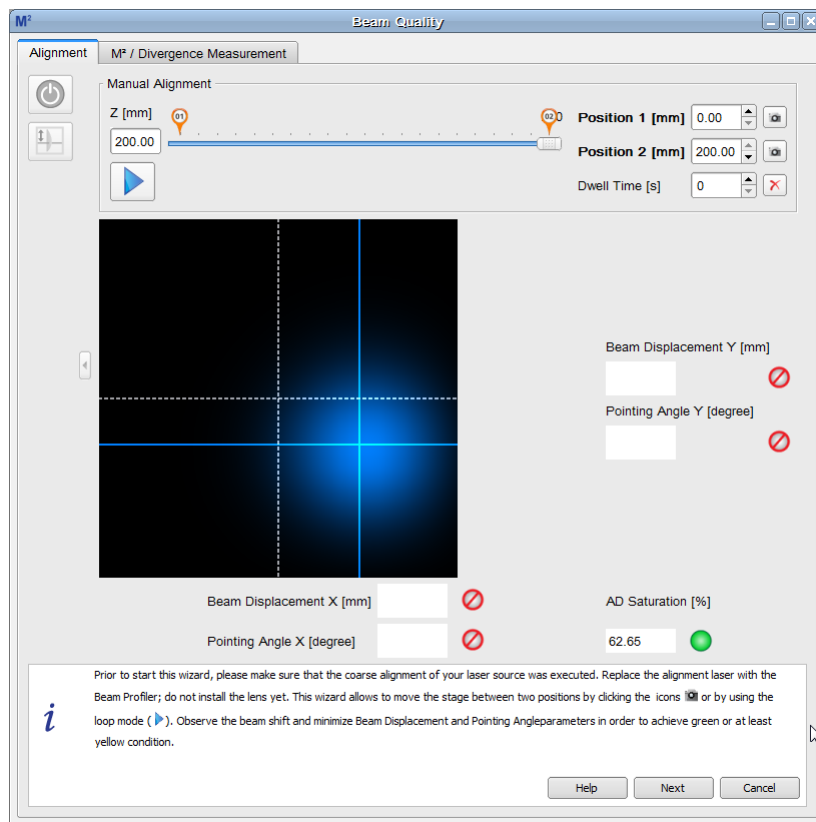

- For a successful alignment, the optical power level must be adjusted in such way that the AD Saturation is between 50 to 95 %. The green bulb to the right of the numeric field indicates the "GOOD" range. During alignment this condition must not change!
- After initialization, the stage is at Position 2 (200 mm). Click the capture button  of Position 2 - the centroid is captured, and its crosshair color changes to amber. As the actual beam centroid that is marked by a blue crosshair, is located at the same position, the resulting color is white:

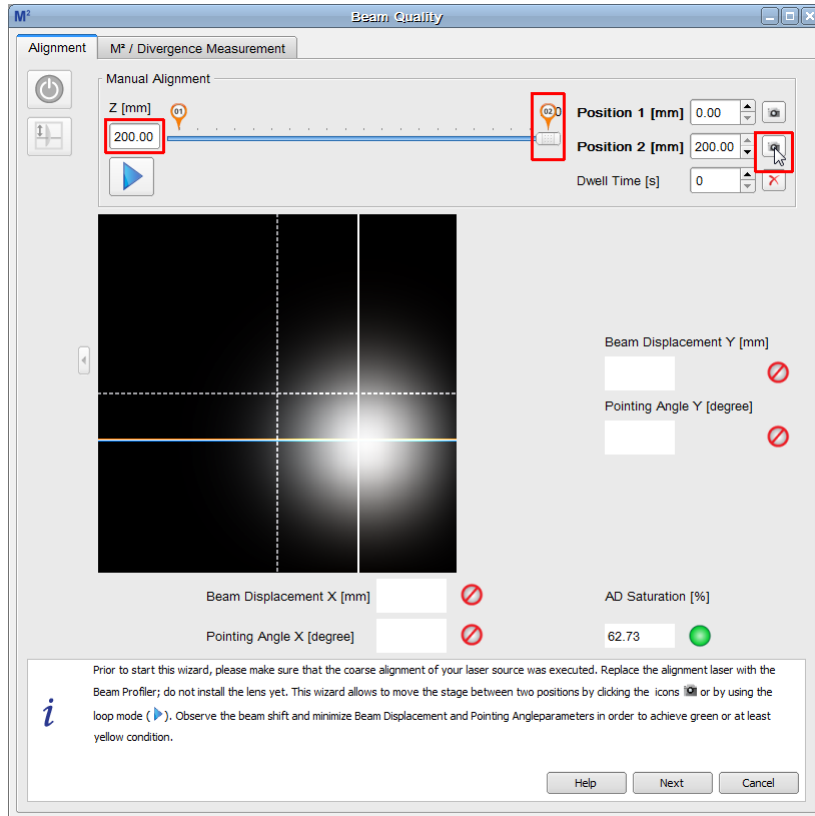

Centroid captured at Position 2

- Click to the Position 1 capture button (0 mm). The stage moves to Position 1 and captures the second centroid position:

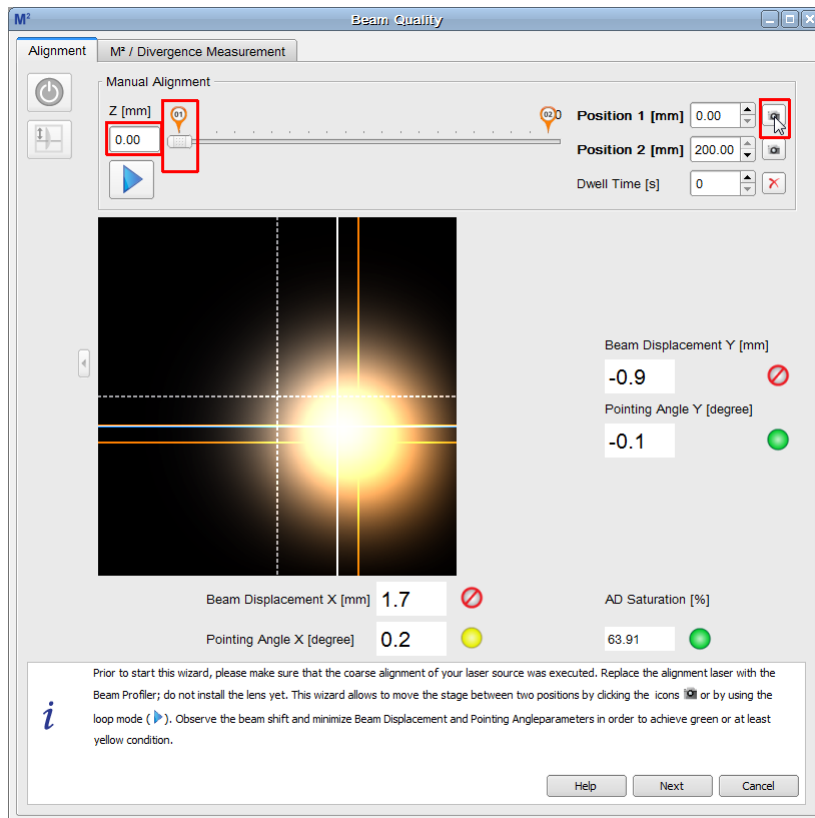

Centroid captured at Position 1

- Now, the beam displacement and the pointing angle are displayed numerically.
- Align the beam position using the controls of your laser source. Subsequently click the capture button of Position 1 and 2, observe the alignment, and improve it until all four alignment criteria are fulfilled (bulbs must be at least yellow):

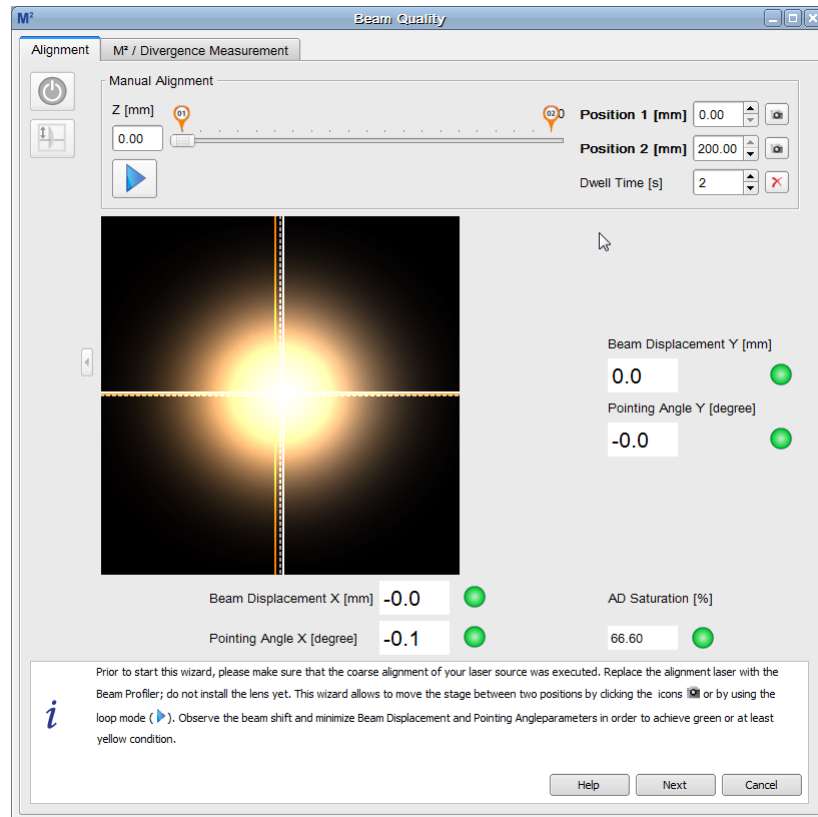

Well aligned beam position

- To toggle between the two positions, the movement of the stage between the two stop positions can be controlled automatically by the software. Just push the loop button  and enter a convenient dwell time value. The stage starts a loop move, dwelling at the stop position for the given time. During the dwelling a realignment can be made. Please keep in mind, that the numeric alignment indicators are being updated only after the next move.

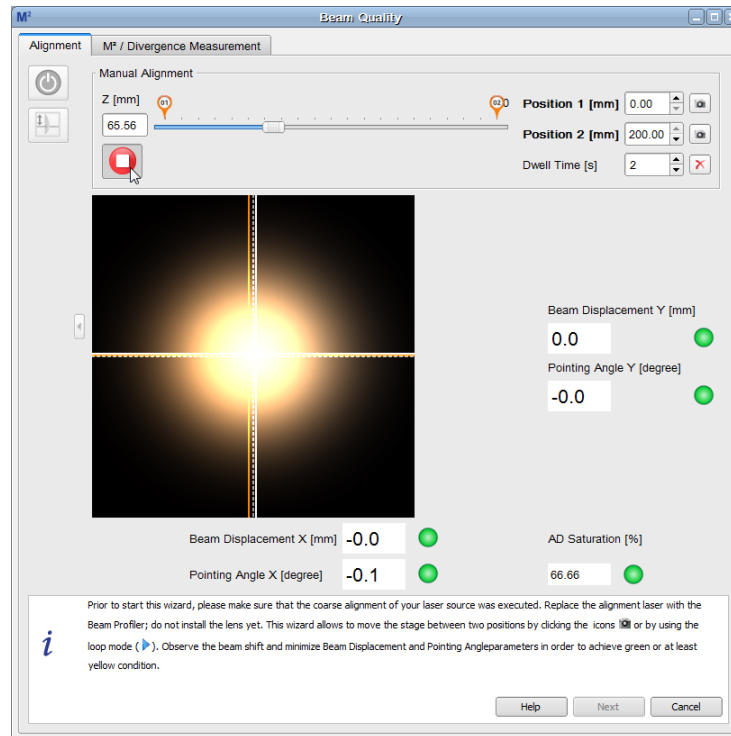

Alignment Move Loop

- To terminate the loop, click the  button.
- After finishing, click **Next** to continue.

5.6.6.1.2.2 Alignment of the Focusing Lens

- After finishing the Beam Alignment, the wizard guides you to the alignment of the focusing lens. As a first step, capture the beam position without lens, then click "Next":

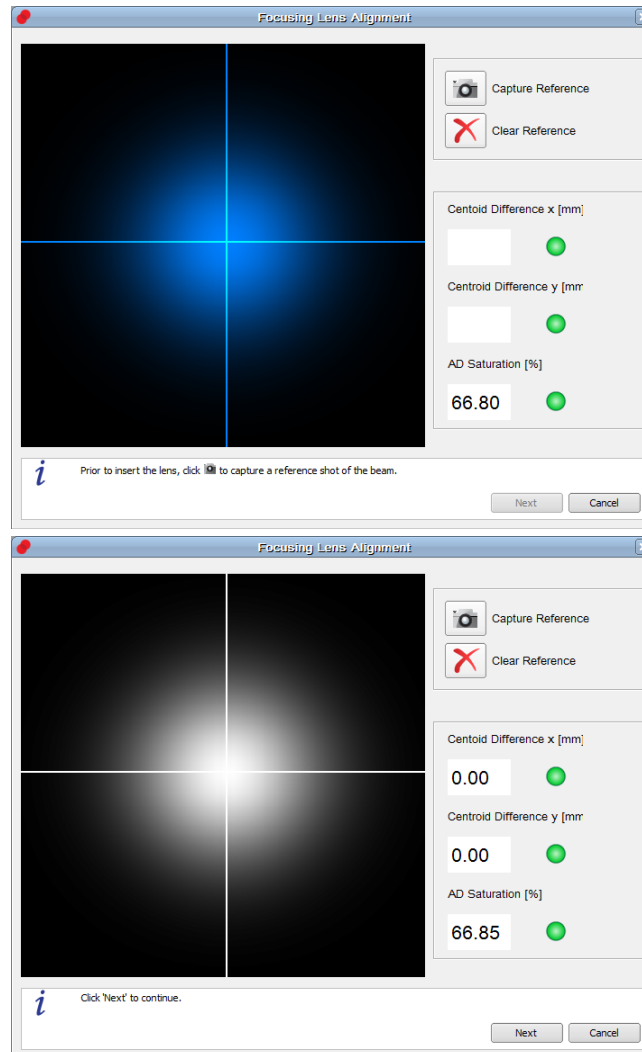

- Verify that the holder of the focal lens is centered (markers on the CXY1 translator and the lens holder should match), place the the mounted focal lens back to the magnetic holder.
 - Make sure that the bullet next to the AD Saturation is still in green or at least yellow.
 - Observe the actual beam position and minimize the difference to the reference, using the X-Y translators of the lens holder until the indicators are green or at least yellow.



- Then click "Next" to finish the Focusing Lens Alignment.
- Select if you want to continue with an M^2 measurement:

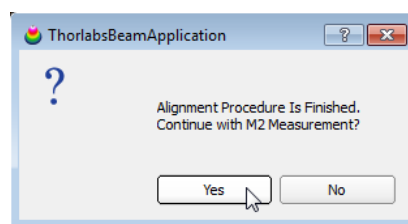





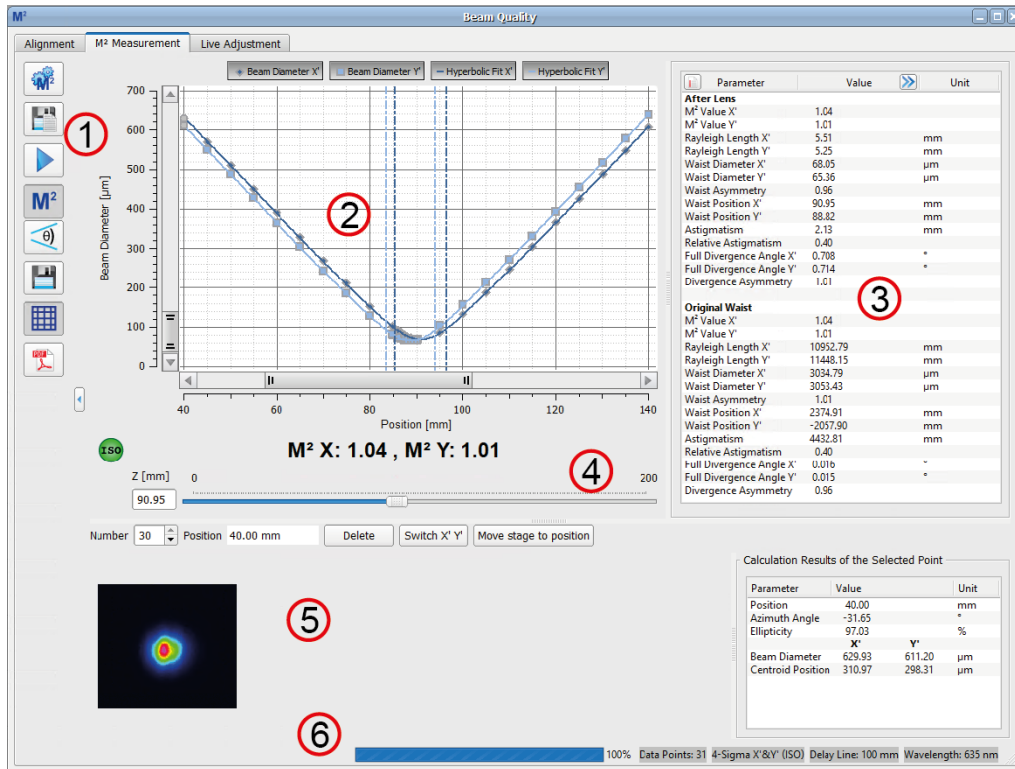



5.6.6.2 M² Measurement Panel

This section concerns the M² measurement and its settings. Click "M2 Measurement" in the **Beam Quality Measurement** window to enter the M² Measurement section.



The M² panel is divided into 6 subpanels:

1. Toolbar

- 
M² Settings
Opens the [Settings](#)^[114] for the M² measurement
- 
Auto Save Data
[Save Beam Profile Data during M² Measurement](#)^[117]
- 
Start / Stop
Starts / stops a M² measurement
- 
M²
Switches to M² measurement
- 
Divergence
Switches to Divergence measurement
- 
Save Data
After a successful M² measurement this button is enabled and plot data can be saved.
- 
Grid
Disables/Enables the grid in the diagram
- 
PDF Test Protocol
Saves the results of a M² measurement into a PDF file

2. M² Diagram

The measured data are plotted in the diagram. The 4 buttons above the diagram allow the display to be configured:

- The buttons **Beam Diameter X' (Y')** enable / disable the display of the measured data at the individual positions
- The buttons **Hyperbolic Fit X' (Y')** enable / disable the curve fit to the measured data points.

Following the measurement, the results for the X and Y axes are displayed. To the left, an indicator shows if the measurement was successful and ISO compliant. See also section [M² Troubleshooting](#)^[125].

The button  between the toolbar and the diagram expands the diagram over the entire M² window.

3. Numeric Results

In this area, the Beam Quality measurement results are displayed in detail. Please see section [M² Measurement Results](#)^[120] for more details. The displayed parameters can be configured through the icon in the upper left corner of subpanel 3.

4. Position Bar

The Position Bar below the M² Diagram shows the actual position of the translation stage as seen before in the **Alignment** tab.

5. Selected Data Points

Select in the header of this sub-panel the **Number** of the desired measured data point. For this selected point, the position of stage and the the 2D projection of the beam is displayed. The table **Calculation Results of the Selected Point** to the right contains the following information:

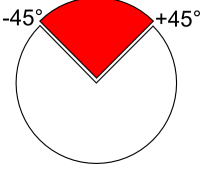
Parameter	Explanation
Position [mm]	The actual Z position of the translation stage for the selected data point.
Azimuth Angle [deg]	For 4σ beam widths the azimuth angle is the absolute azimuth angle, calculated in accordance with ISO11146-1 using 4σ beam widths. Note that the rotation range is <u>not</u> identical with the Orientation ^[64] used for the ellipse. Rotation angle range: <div style="text-align: center;">  </div>
Ellipticity	The ellipticity of the fitted to an ellipse beam (see Application Note ^[171])
Beam Diameter X' [μm] Beam Diameter Y' [μm]	For 4σ beam widths these are the ISO11146 compliant 4σ beam diameters in the transformed coordinate system (not lab system) at the actual Z position. In case of ellipse clip level beam widths the shown values are the minor and major ellipse axes.
Centroid Position X' Centroid Position Y'	The positions of the beam centroids.

6. Status Bar

- Measurement progress bar
- Total number of measured data points
- Beam width setting for M^2 measurement
- Delay Line: Measurement range (difference between Start and Stop positions)
- Wavelength setting for beam quality calculation

5.6.6.3 M² Settings

For a successful and reliable measurement, the appropriate measurement settings are essential. Click  to enter the **M² Measurement Settings** dialog.

Beam Width

Gaussian Diameter: The beam profile will be fit using a Gaussian curve prior to the determination of the beam width. A Gaussian fit can reduce the impact of noise and/or unstable beam shape on the results.

Beam Width Clip (1/e²): This is the value specified in ISO standard 11146-3. If a different clip level was used for normal Beam Profiler operation this will be overwritten by the M² measurement initialization.

Correct Beam Width: This option should be activated by default. Due to the finite slit width so called convolution errors (blurred beam shape) appear, particularly at small beam diameters, that results in an artificial increase of the beam width. Since this convolution error is systematic it can be calculated and eliminated. This feature increases the measurement accuracy, particularly when measuring narrow beams.

Measurement Parameters

Setting the wavelength is mandatory for a correct M²

measurement. If the lasing wavelength is unknown, measure the wavelength using a spectrometer.

Attention

Do not use the nominal wavelength of the laser, use the actual (measured) value! Accuracy of this input significantly impacts the measurement accuracy.

Measurement Range

The **Measurement Range** determines the distance between the Start and Stop position, in other words, the travel distance of the sleigh during the measurement. The travel distance can range from 5 mm to the full length of the stage.

Min. Data Points is the (minimum) number of Z positions at which measurements will be made.. The actual number depends also on the **Scan Method**.

Timeout is the max. waiting time for a valid camera image. This is to allow the Auto exposure function to obtain a valid camera image.

Scan Method

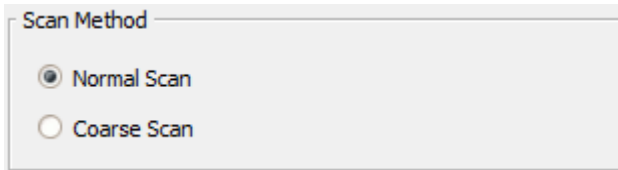

The software provides two different kinds of scan methods, the **Normal Scan** and the **Coarse Scan**.

The **Coarse Scan** just moves the translation stage from **Start** to **Stop** positions (or vice versa depending on the position prior to start the measurement). The number of recorded beam widths equates exactly to the entered number of **Data Points**.

The **Normal Scan** pursues an ISO compliant measurements. The ISO standard requires that

"... at least 10 measurements shall be taken. Approximately half of the measurements shall be distributed within one Rayleigh Length on either side of the beam waist, and approximately half of them shall be distributed beyond two Rayleigh Lengths from the beam waist."

The first run of the Normal Scan is executed with respect to the entered number of **Data Points**, in other words, like a coarse scan. A preliminary Rayleigh Length is calculated in order to evaluate if the number of measured data points is sufficient to fulfill the ISO standard requirements. If so, a hyperbolic fit is applied. If not, a second run adds additional measurements within the Rayleigh Length on both sides and/or beyond twice the Rayleigh Length.

For a M^2 measurement, running the Normal Scan is highly advised. The coarse scan is suitable for a first estimate of the beam waist position or other preliminary measurements.

Reset



Restores the default settings for M^2 settings:

Parameter	Default Setting
Beam Width	Beam Width Clip ($1/e^2$)
Wavelength	635 nm
Timeout	15 sec
Start	0 mm
Stop	200 mm
Min. Data Points	10
Scan Method	Normal Scan

Calculation Area

The settings for the **Calculation Area** can be made in the [Beam Settings panel](#)⁵⁰. During a Beam Quality Measurement (M^2 or Divergence), the Automatic Calculation Area is enabled by default for effective noise reduction. Reflections and artifacts from filters, lenses or other optical elements can be suppressed as well using the automatic Calculation Area.

This setting can be changed to manual, but this may affect the measurement.

By default the Clip Level of the Calculation Area is set to 1%. This is a reasonable value for most applications and measurements. Lowering the clip level leads to increased calculation area and noise level, this way increasing the measured the beam width.

For some cases it might be useful to adjust the Clip Level to cover the whole intensity.

Initial settings

Independently from the user-defined settings the following options are set automatically for every beam quality measurement.

Setting	Parameter
Calculation Area	Automatic
Auto Exposure	On
Ambient Light Correction	remains as set
Ellipse Clip Level	13.5%
Approximate Ellipse	On

Note

It is strongly recommended to run an [ambient light correction](#)^[40] prior to any measurement, and then enable Ambient Light Correction. This ensures the most accurate measurement.

Please be aware of the fact that ambient light correction is disabled any time the Beam Software is started and/or the settings for [attenuation](#)^[39] (filter wheel) are changed in the software.

5.6.6.4 Saving the M² Measurement Results

Besides the standard function "[Save M² Test Results](#)"^[116] the Thorlabs Beam Software offers an [automatic saving of beam profile data](#)^[117] when an M² measurement is executed.

5.6.6.4.1 Saving M² Test Results

The beam quality measurement results can be saved in two different ways:

1. Save Test Results

 Save measurement data as CSV (default). The [Save Test Protocol](#)^[91] dialog opens, select the desired path, file name and file format (csv, txt or xls), fill in the desired fields and click Save.

2. Save Test Protocol

 Save measurement data as *.pdf file. The [Save Test Protocol](#) dialog opens, fill in the desired fields and click Save. The M² Measurement Results will appear in the PDF documents.

5.6.6.4.2 Saving Beam Profile Data During M² Measurement

During an M² measurement, the beam profile calculation results, the device data and the M² measurement results can be saved automatically at each position of the translation stage.

To configure this automatic data export click the  icon in toolbar on the left side of the M² panel. A dialog opens:

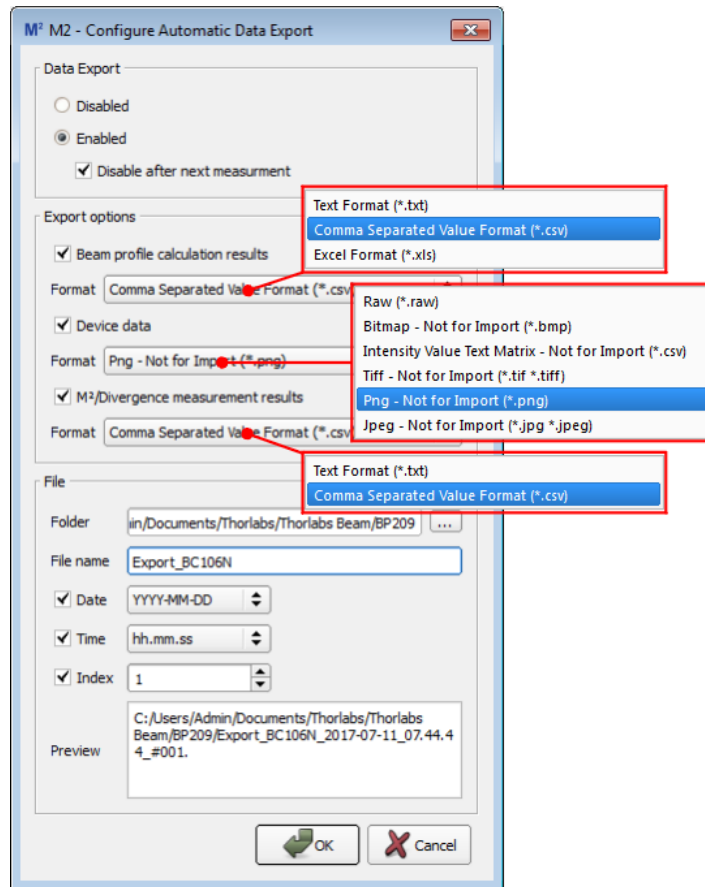

Section Data Export

Select **Enable** to activate the automatic export. The toolbar icon changes to  and the status bar on the bottom of the GUI appears as

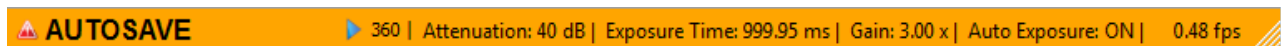

The Data Export remains active until **Disable** is checked. If the data shall be saved only once, please check the boxes

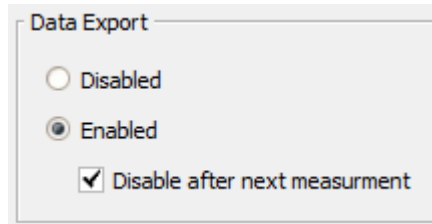

Select **Disable after next measurement** to stop the automatic export after the first run of the M^2 measurement.

Section Export Options

Here the data to be exported can be selected by checking the appropriate box.

Beam Profile Calculation Results can be saved as .csv, *.txt, or *.xls files. A single file is saved; for each stage position the data are appended to the existing file. The export file contains the header (information about Beam Software version, time stamp of measurement start, and information about the used beam profiler) and all calculation results (see section [Calculation Results](#)⁶⁴; option "Select All"). The name of this file is formed by appending the string "data" to the base file name.

With **Device Data** enabled, at each stage position the intensity values that are retrieved from the beam profiler are saved to an individual file. For device data and file formats, please see section [Export Device Data](#)⁸⁷. The name of this file is formed by appending the string "device" to the base file name.



When **M^2 / Divergence Measurement Results** is enabled, the M^2 test results are saved in *.txt or *.csv format as well; see section [Saving \$M^2\$ Test Results](#)¹¹⁶.

Section File

- Select the desired target file folder for the automatic data export.
- Choose a file name.
- Add the date (optional)
- Add the time stamp (optional)
- Add an index (optional). The index must be set manually!
- The box Preview shows the prefix of the file name with selected options.

When done, click **OK**. Now, the M^2 measurement with automatic data export can be started.

File Naming with Automatic Data Export

Beam Profile Calculation Results	
 Export_BC106N_2017-07-11_07.44.44_#001_Data.csv	
prefix with date, time and manual index	"Data" stands for Beam Profile Calculation Results
Device Data	
 Export_BC106N_2017-07-11_07.44.44_#001_Device_2017-07-11_09.14.56_#001.png	
prefix with date, time and manual index	"Device" stands for Exported Device Data (here: image of the beam). Followed by individual time stamp and automatic index of the appropriate stage position
M^2 / Divergence Measurement Results	
 Export_BC106N_2017-07-11_07.44.44_#001_Results.csv	
prefix with date, time and manual index	"Results" stands for M^2 test results

5.6.6.5 Running the M² Measurement

Prior to starting a measurement, make sure that the following conditions are fulfilled:

- The beam is aligned properly - it should ideally remain centered with respect to the sensor center over the entire scan range. Section [Beam Alignment](#)^[101] describes in detail how to achieve this.
- The beam diameter should be in accordance with the [Requirements to Beam Diameter](#)^[95].
- The exact wavelength of the laser under test is well known, as the wavelength value influences the M² results.
- Ambient light may disturb the measurement and should be avoided.
- Reflections and interferences are avoided as far as possible.
- The laser system is warmed up - depending on the source this might take up to 1 hour.
- The laser output is spatially and temporally stable.

Start the measurement by clicking the **Start** button ▶.

You will be prompted to confirm the laser wavelength:

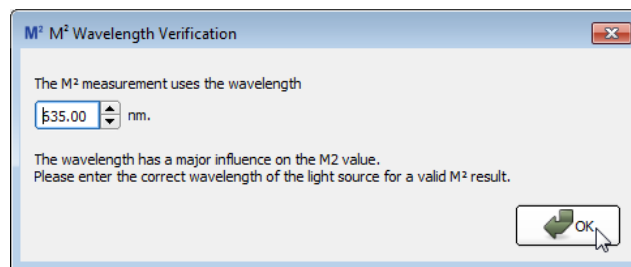

Verify the wavelength and click **OK**.

While running the measurement most of the buttons and options are disabled, e.g. the M² Measurement Settings and the Toolbar. This is intentional and prevents any settings changes during the measurement.

The measurement can be interrupted at any time by clicking the **Stop** button ◻.

After starting the measurement the X axis of the graph is adapted to the user-defined scan range, for example from 50 to 125 mm. The Y axis scales automatically to the recorded beam width.

If the **Normal Scan** is applied the scale on the graph zooms in when the fine scanning adds additional data points. After this step (at the end of the measurement) the full scan range is shown again.

5.6.6.6 M² Measurement Results

After a successful M² measurement, the **Beam Quality Measurement** window shown below appears.

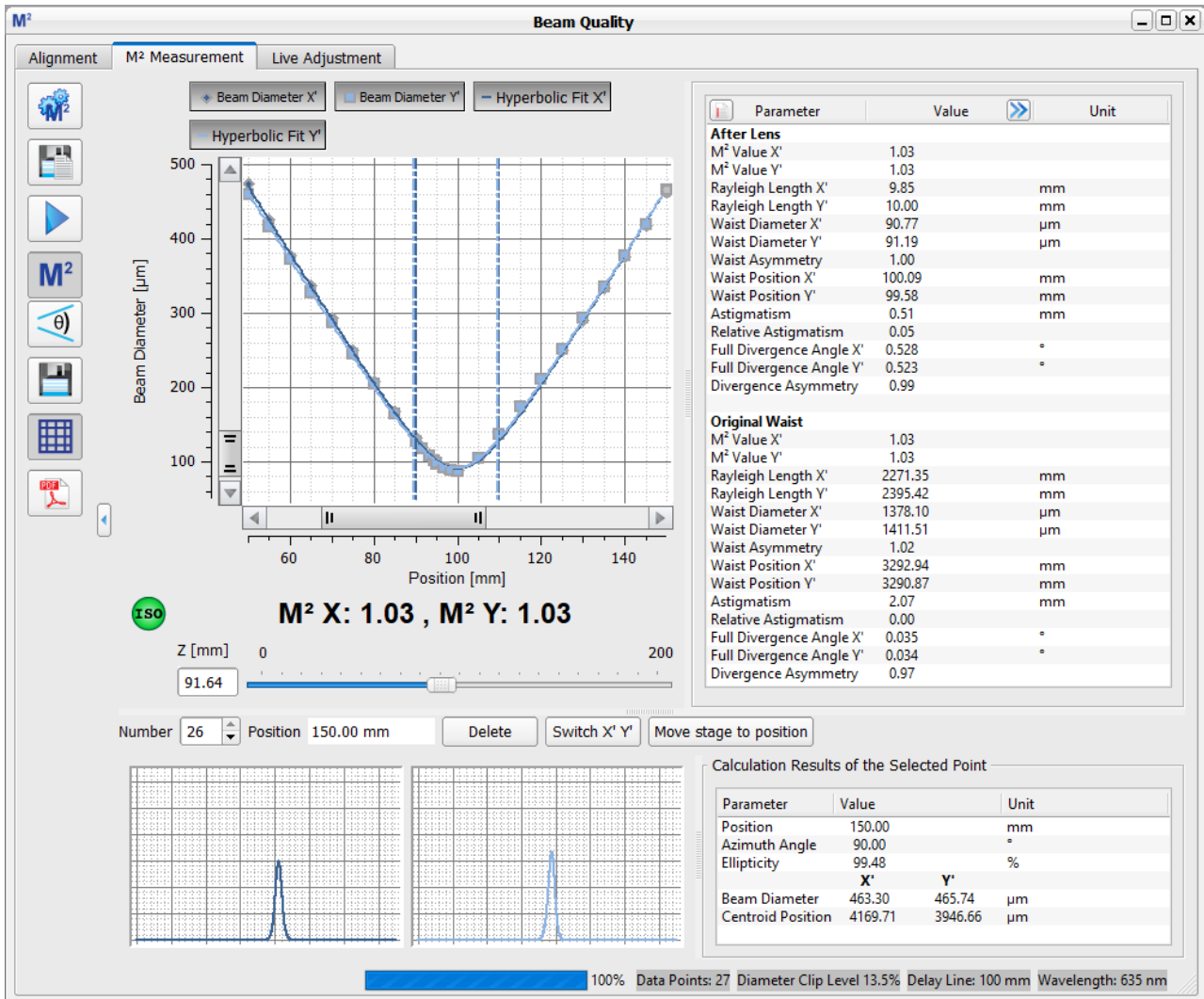

The green bulb indicates that the measurement was successful and fulfills the ISO 11146 standards:

ISO M² X: 1.03, M² Y: 1.03

In the case that beam criteria different from the ISO standard beam width criteria were used (see [M² Settings](#)₁₁₄), a successful measurement is shown without the ISO indication:

M² X: 1.10, M² Y: 1.07

In general, the X' and Y' axes do not coincide with the lab system (described by the X and Y axes). Furthermore, the M² value for X' is independent from the one for Y'. For highly elliptical beams, such as those from semiconductor lasers, M²X' and M²Y' will differ much more than in this example.

Diagram Legend

- Beam Diameter X'
- Beam Diameter Y'
- Hyperbolic Fit X'
- Hyperbolic Fit Y'

These values can also be found in the listing of the complete results next to the diagram:

Parameter	Value	Unit
After Lens		
M ² Value X'	1.03	
M ² Value Y'	1.03	
Rayleigh Length X'	9.85	mm
Rayleigh Length Y'	10.00	mm
Waist Diameter X'	90.77	µm
Waist Diameter Y'	91.19	µm
Waist Asymmetry	1.00	
Waist Position X'	100.09	mm
Waist Position Y'	99.58	mm
Astigmatism	0.51	mm
Relative Astigmatism	0.05	
Full Divergence Angle X'	0.528	°
Full Divergence Angle Y'	0.523	°
Divergence Asymmetry	0.99	
Original Waist		
M ² Value X'	1.03	
M ² Value Y'	1.03	
Rayleigh Length X'	2271.35	mm
Rayleigh Length Y'	2395.42	mm
Waist Diameter X'	1378.10	µm
Waist Diameter Y'	1411.51	µm
Waist Asymmetry	1.02	
Waist Position X'	3292.94	mm
Waist Position Y'	3290.87	mm
Astigmatism	2.07	mm
Relative Astigmatism	0.00	
Full Divergence Angle X'	0.035	°
Full Divergence Angle Y'	0.034	°
Divergence Asymmetry	0.97	

M² X' and M² Y' are the M² value for X' / Y' axis, calculated from the hyperbolic fit of the measured data points.

Rayleigh Length X' (Y') is the calculated distance [mm] from the beam waist position X' (Y') to the position, where the beam diameter of the appropriate axis is $\sqrt{2}$ times larger than the waist diameter. See also section [M2 Theory](#)^[143].

Waist Diameter X' (Y') is the beam diameter in the X' (Y') direction at the focal point. This is the calculated minimum beam diameter [µm], derived from the curve fit. This value may differ from the smallest measured beam width.

Waist Asymmetry stands for the ellipticity at the waist position and is calculated by taking the ratio of the waist diameters in both X' and Y' directions. A waist asymmetry of 1.0 indicates a round beam spot.

$$\text{waist asymmetry} = \frac{d_{0y}}{d_{0x}}$$

Waist Position X' (Y') Z position of the beam waist (smallest beam diameter). This is the calculated beam waist position in mm derived from the curve fit. This value may differ from the position where the smallest beam width was measured.

Astigmatism is known as the effect that the beam waist in X and Y scan direction is not at the same z position. So there is a difference between the positions of minimal spot diameters z_{0y} and z_{0x} .

$$astigmatism_abs = z_{0y} - z_{0x}$$

Relative Astigmatism is calculated from the Astigmatism values divided by the mean of the Rayleigh Length in X and Y.

$$astigmatism_rel = \frac{Z_{01_Y} - Z_{01_X}}{(Z_{R1Y} - Z_{R1X}) \div 2}$$

Full Divergence Angle is explained in section [M2 Theory](#)^[143].

Divergence Asymmetry is the ratio of the divergence angles in Y and X axes. Values differing from 1.0 indicate that the beam ellipticity is changing with Z position, for instance when an elliptical beam is focussed to a round spot.

$$divergence\ asymmetry = \frac{\theta_y}{\theta_x}$$

Note

All results are calculated from the applied fit!

Display the Results at a Certain Z Position

After measurement is finished, the calculated beam diameter, the beam centroid positions (X' and Y'), and the beam ellipticity as well as azimuthal angle can be retrieved for a certain Z position from the diagram. To do this, move the mouse pointer over the measured curves. For better visualization, the curves can be zoomed by dragging a rectangle:

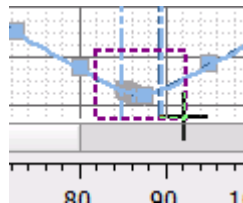

As soon as the mouse pointer hits a measurement point, its shape changes to . Click this point. The position and calculated values corresponding to the clicked point will appear in the **Calculations Results of the Selected Point** panel:

Parameter	Value	Unit
After Lens		
M ² Value X'	1.03	
M ² Value Y'	1.03	
Rayleigh Length X'	9.85	mm
Rayleigh Length Y'	10.00	mm
Waist Diameter X'	90.77	μm
Waist Diameter Y'	91.19	μm
Waist Asymmetry	1.00	
Waist Position X'	100.09	mm
Waist Position Y'	99.58	mm
Astigmatism	0.51	mm
Relative Astigmatism	0.05	
Full Divergence Angle X'	0.528	°
Full Divergence Angle Y'	0.523	°
Divergence Asymmetry	0.99	
Original Waist		
M ² Value X'	1.03	
M ² Value Y'	1.03	
Rayleigh Length X'	2271.35	mm
Rayleigh Length Y'	2395.42	mm
Waist Diameter X'	1378.10	μm
Waist Diameter Y'	1411.51	μm
Waist Asymmetry	1.02	
Waist Position X'	3292.94	mm
Waist Position Y'	3290.87	mm
Astigmatism	2.07	mm
Relative Astigmatism	0.00	
Full Divergence Angle X'	0.035	°
Full Divergence Angle Y'	0.034	°
Divergence Asymmetry	0.97	

Parameter	Value	Unit
Position	150.00	mm
Azimuth Angle	90.00	°
Ellipticity	99.48	%
Beam Diameter	X': 463.30 Y': 465.74	μm
Centroid Position	X': 4169.71 Y': 3946.66	μm

Note



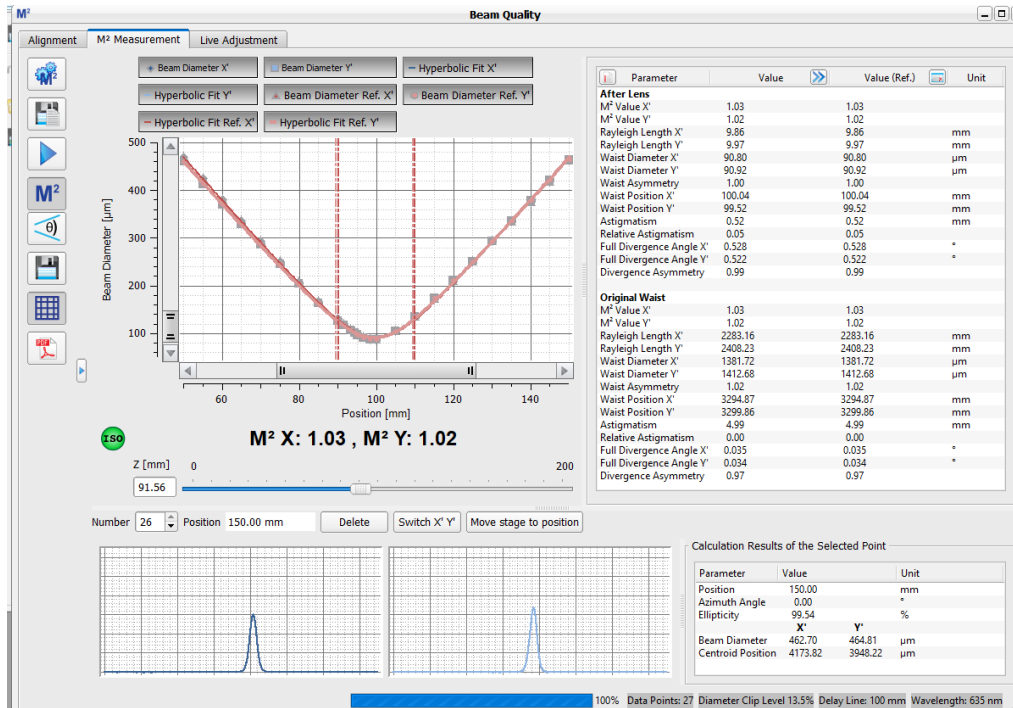

In contrast to the **Results** pane, the results shown here are calculated from the measured data point without a hyperbolic fit. Therefore, the diameter value displayed at the actual waist may differ from the X' (Y') waist diameters.

Reference Measurement

After a M² measurement is completed, the results can be saved and afterwards used as a reference. To do this just click the  button, the active results become the reference. Further, the reference data are added to the diagram in a different color.



Reference Diagram Legend:

-  Beam Diameter Reference X'
-  Beam Diameter Reference Y'
-  Hyperbolic Fit Reference X'
-  Hyperbolic Fit Reference Y'

Clicking to the Clear  icon deletes the reference data.

Please refer to section [Saving M² Test Results](#)¹¹⁶ for details about how to save the results of the beam quality measurement.

5.6.6.7 M² Troubleshooting

Below are examples of typical problems that may occur and appropriate recommendations for resolving them.

The beam does not hit the sensor at all positions of the stage.

Perform a proper [Beam Alignment](#)^[101].

A timeout error occurs during a measurement.

A timeout always occurs when the Beam Profiler camera does not get a valid image. This may be caused by:

- Saturation of the camera. Since the beam is focused the intensity is the higher the smaller the beam width. This may lead to a saturation of the camera. To resolve, attenuate the laser beam with additional ND filters or decrease the laser output power. Alternatively use a lens with larger focal length if possible; this will increase the diameter of the focal spot and in this way lower the focal power density.
- A Normal Scan is applied and the Fine Scan shall add data points. The exposure time has then to change from long exposure times to small values. This can take more time than the timeout allows. Set the timeout to a greater value to solve this problem ([M² Settings](#)^[114]).
- The beam power is too low for the sensor. Remove ND filters or increase output power of the laser.
- The beam size is too small and no ellipse could be calculated (if Clip Level Ellipse is selected as beam width). Use a lens with a longer focal length to increase focal beam size.
- The beam does not hit the CMOS sensor. Align the beam, see section [Beam Alignment](#)^[101].

Parasitic reflections walk over the CMOS sensor during the measurement.

This may happen, if the beam is not perfectly aligned and/or the filters are not parallel to the CMOS chip. The laser beam is reflected from the CMOS surface back to a filter and again back to the CMOS sensor. The position of such a double reflection changes with stage movement.

The detection of these reflections can be improved by using the logarithmic color scale that accentuates smaller intensities.

The scale can be switched from **linear** to **logarithmic** by clicking on the color scale.

Then perform a proper [Beam Alignment](#)^[101].



The M² value differs substantially from the expected value.

For example, the beam has a nearly Gaussian intensity distribution and M² values are larger than 1.1:

- Check set wavelength (see [M² Settings](#)^[114])
- Check Clip Level of the **Calculation Area**:
 - ▶ If the selected Clip Level is too high, the beam might be cut off and the measured beam area might be smaller than the actual beam extend. This results in a too small beam waist and a too small M² (even below 1).
 - ▶ If the selected Clip Level is too low, the Calculation Area and the measurement captures the beam plus noise around the beam. The measured beam width is then larger than the actual

beam width. This leads to an increased M^2 .

❑ M^2 is smaller than 1.0

M^2 values < 1.0 are non-physical but may be due to

- A Calculation Area that is too small (Clip Level too high - see [M2 Settings](#)^[114])
- The accuracy of the measured result. A error of 5% should be considered.
- The wavelength setting was not made properly. Set the wavelength to the correct value; M^2 results will be corrected without running a new measurement.

❑ The beam profile looks distorted (particularly, at the end positions of the stage).

Even if a laser is expected to produce a Gaussian beam with $M^2 = 1.0$, the beam still can be influenced by every optical element between laser and Beam Profiler. For instance, a focusing lens could be mounted with a tilt or could produce a height distortion which results in optical aberrations and reduced beam quality.

Filters and mirrors may impact on the beam profile as well in the case that surfaces are contaminated. Clean surfaces according to manufacturer's instructions.

❑ Error message

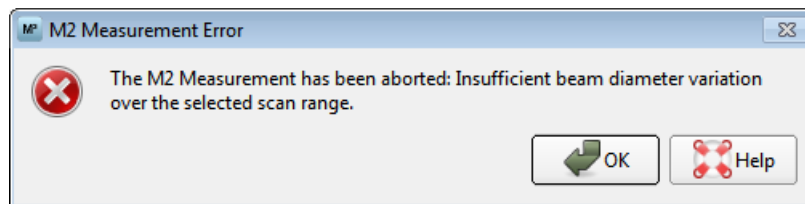

"The M2 Measurement has been aborted: Insufficient beam diameter variation over the selected scan range."

The software could not locate sufficient measurement points within the doubled Rayleigh Length.

- Extend the [Measurement Range](#)^[114].
- Select a focusing lens with a shorter focal length.
- Rule of the thumb: the beam diameter variation within the scan range should not run below a ratio of 1:2.5 at least at one side of the beam waist - see the example below.

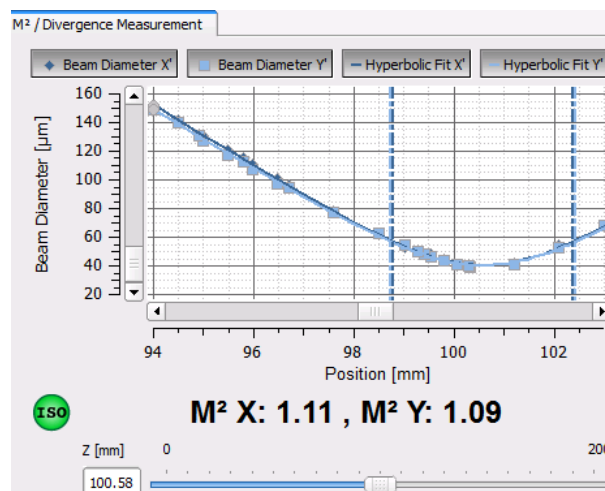

❑ Error message

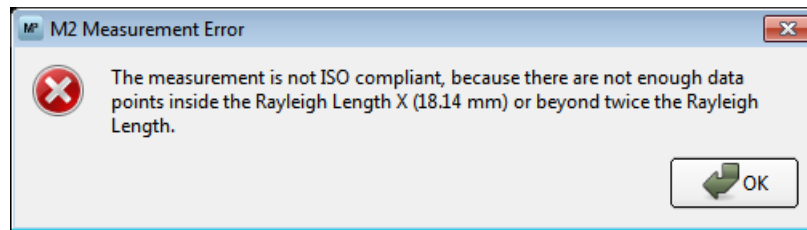

"The measurement is not ISO compliant, because there are not enough data points inside the Rayleigh Length X (Y)(xx mm) or beyond twice the Rayleigh Length"

- The software could not measure with the required resolution.
- Increase the minimum number of data points (see [M² Settings](#)¹¹⁴).
- If the error message persists, increase the scan range as well.

❑ Error message

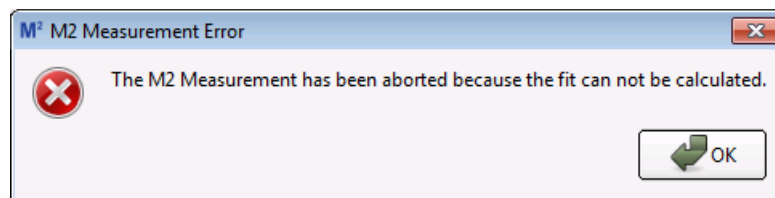

"The M2 measurement has been aborted because fit cannot be calculated."

- The calculation of the hyperbolic fit from the measured data points is impossible. Possible reasons are, for example, that the beam waist is far away from the scan range, or that no focal lens was used.
- Reset the M² Settings to default - that sets the scan range to its maximum.
- Check your setup to make sure the beam waist is within the scan range.
- If no focal lens was used, only a divergence measurement is possible!

❑ Error message

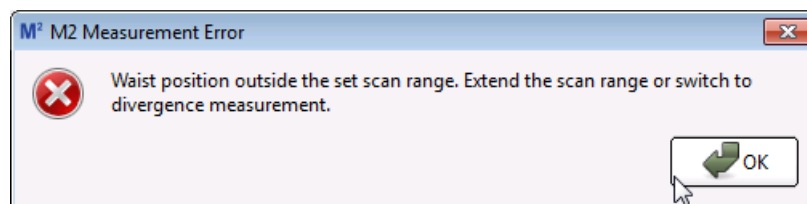

"Waist position outside the scan range. Extend the scan range or switch to divergence measurement."

- The calculation of the hyperbolic fit from the measured data points resulted in a beam waist position outside the scan range. Usually this happens if the beam waist is close to one of the scan end positions. Extend the scan range.
- Reset the M² Settings to default - that sets the scan range to its maximum

5.6.6.8 Live Adjustment

Open the Live Adjustment panel and click "start" to move the M2 stage to the lense focus plane as calculated from the inserted parameters. Now, the laser system can be adjusted and, for example, collimation can be optimized until the beam width in the focus plane is minimized.

As the stage moves to the focal plane, the Z-slider on the bottom right moves under the lens focus (LF) icon.

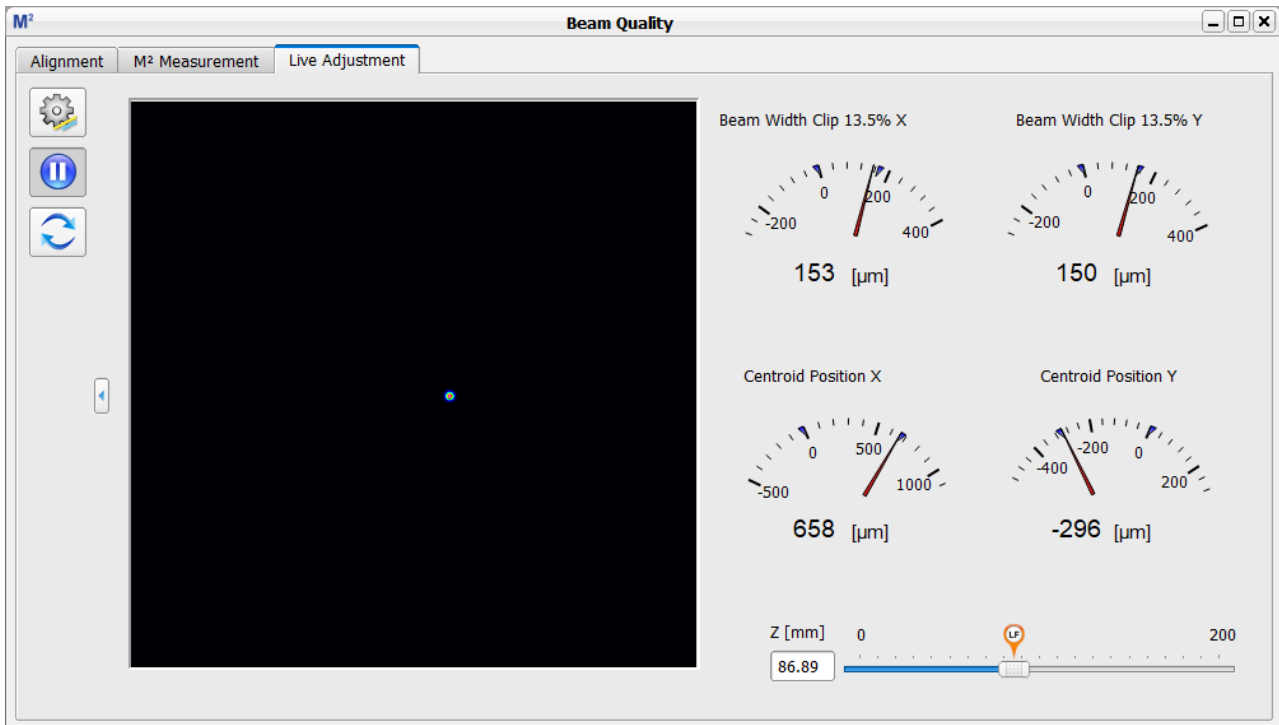

The right panel shows the Beam Width and Centroid Position in X and Y.

Beam Width: The displayed beam width is calculated based on the settings chosen in the Settings Panel of this window opened through the icon on the left.

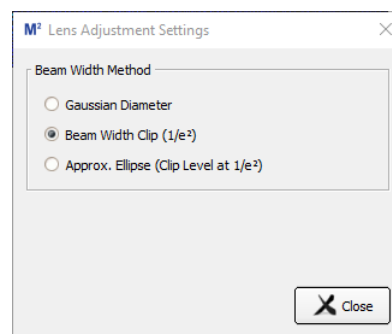

Centroid Position: The Centroid position is displayed to maintain knowledge of the beam position during adjustment.

Adjustment in Z is facilitated by the slider on the bottom right.

5.6.7 Divergence Measurement

The **Divergence Measurement** calculates the divergence angle of an unfocused convergent or divergent beam by measuring the beam diameter at different points along the beam propagation axis. A linear fit is applied to the measured data.

The measurement technique is very similar to the Beam Quality (M^2) measurement, thus the same hardware can be used with exception of the focusing lens.

The Divergence Measurement is part of the [Beam Quality](#) ⁹² measurement tool and uses the M2MS extension as well.

Please open the M2 measurement panel via the M^2 icon to arrive at the alignment and divergence measurement GUI.

To prepare for and perform a divergence measurement, please deselect the M^2 icon on the left side of the window. This will switch the interface to the divergence measurement window.

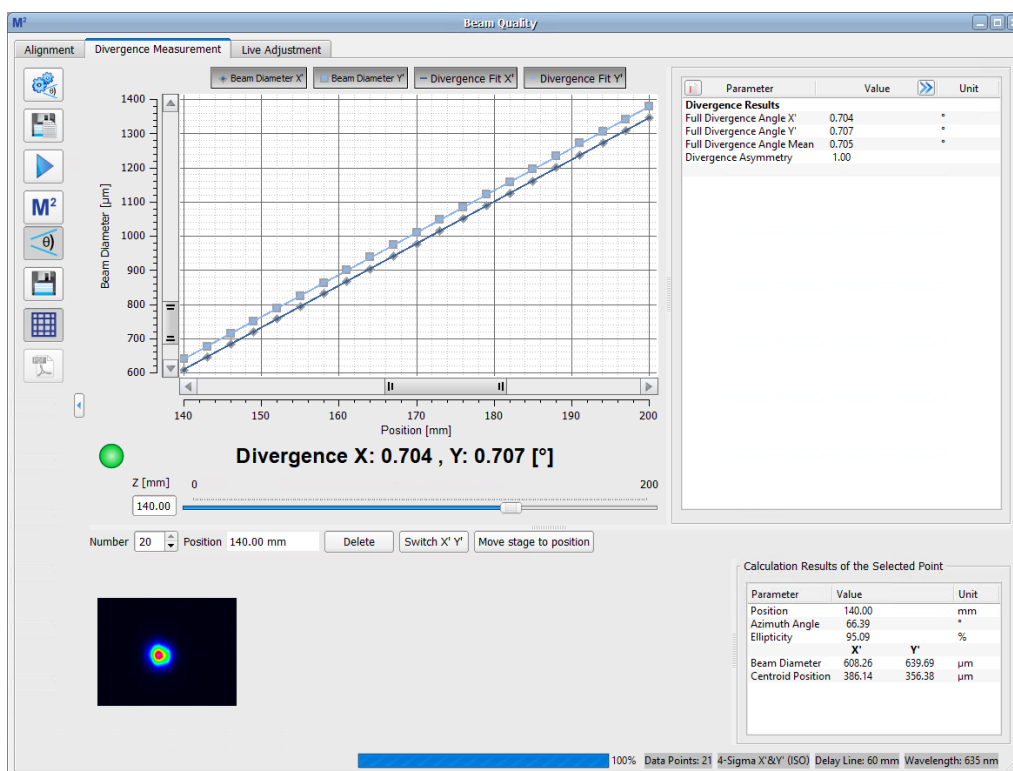

5.6.7.1 Beam Alignment

Why Beam Alignment?

The Beam Profiler has a defined input aperture, so when moving the translation stage it must be ensured that the laser beam remains within the aperture. Ideally, the beam centroid remains centered within the aperture during movement of the stage - this is a precondition for correct beam quality measurements.

The M2MS Measurement System is factory aligned. A beam that enters the M2MS exactly parallel to the stage movement direction will remain centered to the Beam Profiler aperture during stage movement. In other words, the beam alignment is dependent only on the position of the light source. In most cases the light source is a device with open beam output. In order to direct the beam under test into the M2MS, a combination of two adjustable mirrors is required, Thorlabs offers a variety of such items.

The beam alignment is executed in 2 steps, guided by a software wizard:

1. [Coarse alignment](#)^[130]: Determine the correct location of the Laser Under Test output aperture by means of an auxiliary laser (included).
2. [Fine Alignment](#)^[130] of the Laser Under Test for minimum beam displacement and pointing angle.

5.6.7.1.1 Coarse Alignment

For a coarse alignment, Thorlabs provides an alignment laser that is included with the accessory box. For this step, the alignment laser is mounted on the M2MS in place of the Beam Profiler as described below. It is mounted and aligned in such way that its output beam enters the M2MS exactly centered in the Beam Profiler's aperture and is parallel to the stage movement direction. The alignment beam is reverse directed - it virtually exits the Beam Profiler and is redirected by the two mirrors of the stage into the center of the laser source aperture (see the drawing in section [M2MS Operating Principle](#)^[94]).

Warning Be careful when using the Alignment Laser!





- Remove the Beam Profiler together with its mounting adapter from the M2MS base.
- Install the adjustment laser in place of the Beam Profiler and connect its 3.5 mm plug to the [Alignment Laser output \(2\)](#)^[99].
- Make sure the M2MS is switched on and connected to the control PC, the Beam Software is started and the stage has been initialized.
- Remove the focal lens from the magnetic holder.
- Switch on the alignment laser.
- Align your optical system so that the spot of the alignment laser hits the center of your light source.

5.6.7.1.2 Fine Alignment

After coarse alignment, the beam under test needs to be fine-adjusted using the **Alignment** feature of the M² measurement panel. This is executed in two steps.







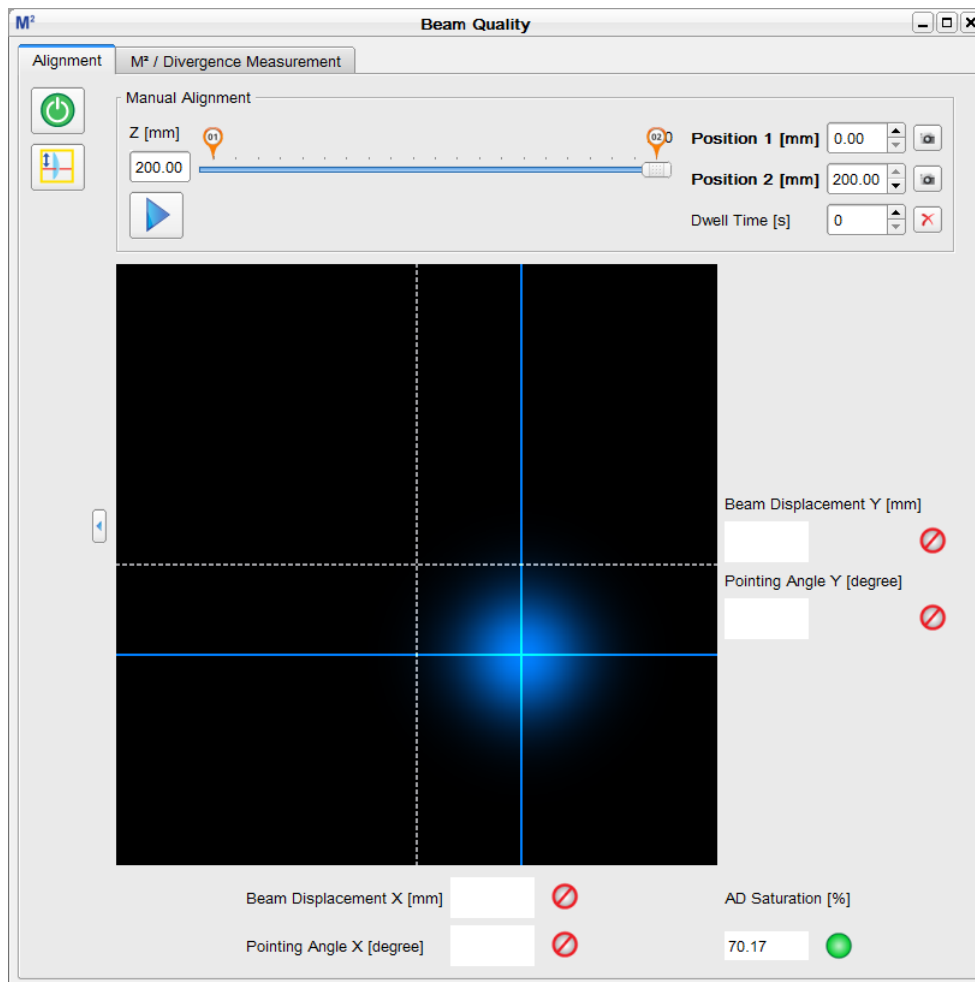



Preparation

- Switch off the alignment laser and replace it with your Beam Profiler.
- Make sure the BC207 or BC210C beam profiler is connected to the PC via the USB3.0 port. When using an older BC106N beam profiler, connect the beam profiler to one of the M2MS USB output ports (see [Connection to the PC](#)^[99] section).
- Remove the focusing lens (see  in the drawing in the [M2MS Operating Principle](#)^[94] section).
- Make sure the BC207 or BC210C Series beam profiler is recognized by the Beam Software (Toolbar  [Device Selection](#)^[100]). If it is not recognized automatically, press the **Refresh Device List**^[25] button.
- Make sure the stage is recognized and initialized. If not, press the [Refresh Stage List button](#)^[100] and after the stage was recognized, double click to the DDS100 button. The stage initializes and moves to the 200 mm position.

- Enable the Laser Under Test.
- Open M² child window either from the menu "Windows" -> "M² Quality Measurement" or by clicking the M² button, and switch to the Alignment tab.



Explanation of indicators and icons

	Start the Alignment Wizard ¹⁰⁵
	Start the Focusing Lens Alignment Wizard ¹⁰⁹
Z [mm]	This box shows the actual stage position; after initialization = 200 mm.
Position 1 (2) [mm]	The left and right positions for the stage movement can be entered numerically.
	Markers for left and right positions. Instead of numerical entry of the marker positions, the markers can be moved by drag-and-drop.
	When clicking these capture buttons, the stage moves to the related position, if not there yet, and captures the beam centroid position (amber crosshair). This snapshot will remain until the stage returns to the appropriate position.
	This button starts the stage loop movement mode and the stage moves continuously between positions 1 and 2. A dwell time at the end positions can be entered. During the loop mode, the software automatically captures the beam centroids (yellow cross hair) at the left and right stop.
Dwell Time	Enter the desired time [sec]. Disable the dwelling by clicking to the  icon.
	Centroid crosshair of the actual beam position.
	Crosshair of the sensor center
Beam Displacement	Centroid shift in X (Y) direction between position 2 and 1 [mm]. The box is initially filled after the 2nd capture.
Pointing Angle	The angle [°] in X (Y) direction between the beam axis and the stage movement direction. The box is initially filled after the 2nd capture.
Alignment Success Indicator	 Alignment not successful  Alignment sufficient for correct Beam Quality Measurement (displacement < 0.65 mm, angle < 0.35°)  Good alignment (displacement < 0.35 mm, angle < 0.15°)
AD Saturation	Displays the current saturation of the Beam Profiler's AD converter. For proper beam alignment function the value must be 50 to 95 %. The green bulb to the right of the numeric field indicates the "GOOD" range.

5.6.7.1.3 Divergence Beam Alignment Wizard

Press the **Start Wizard** button . You will be requested to select whether you want to adjust for M² or Divergence Measurement. Make your choice:

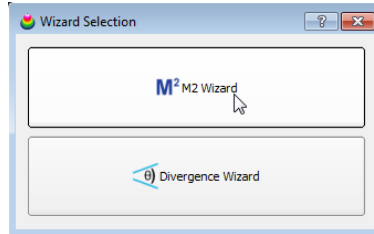

The wizard starts:

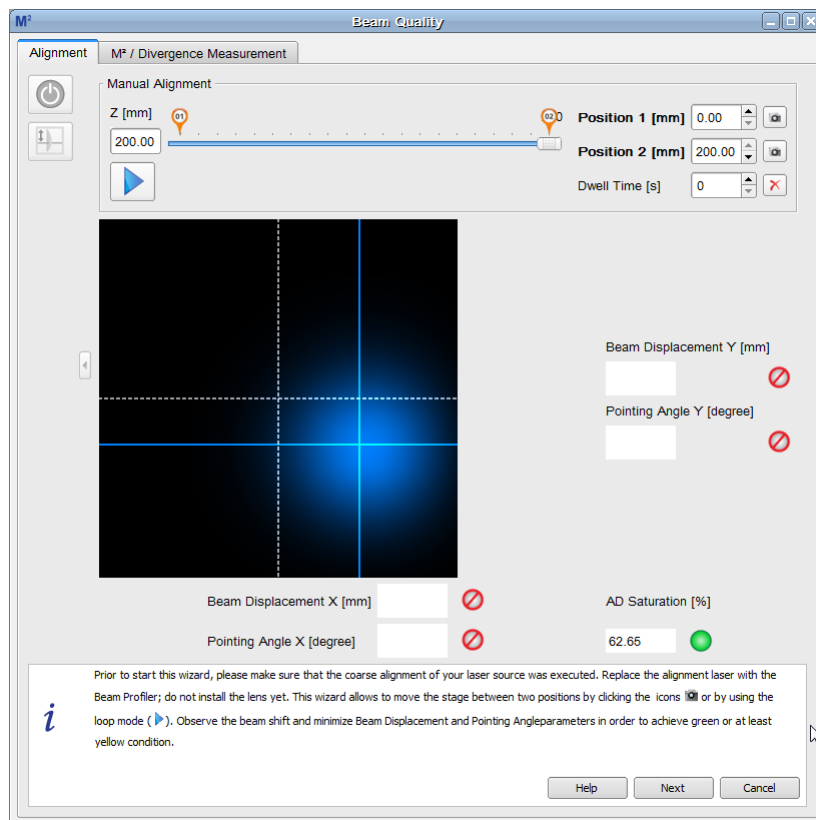

- For a successful alignment, the optical power level must be adjusted in such way that the AD Saturation is between 50 to 95 %. The green bulb to the right of the numeric field indicates the "GOOD" range. During alignment this condition must not change!
- After initialization, the stage is at Position 2 (200 mm). Click the capture button  of Position 2 - the centroid is captured, and its crosshair color changes to amber. As the actual beam centroid that is marked by a blue crosshair, is located at the same position, the resulting color is white:

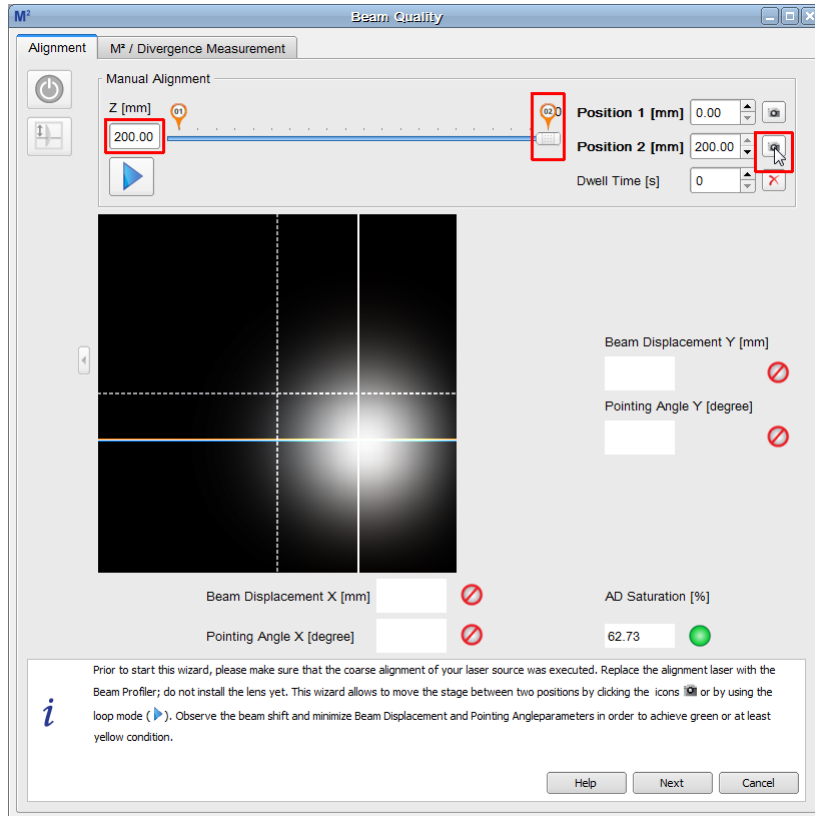

Centroid captured at Position 2

- Click to the Position 1 capture button (0 mm). The stage moves to Position 1 and captures the second centroid position:

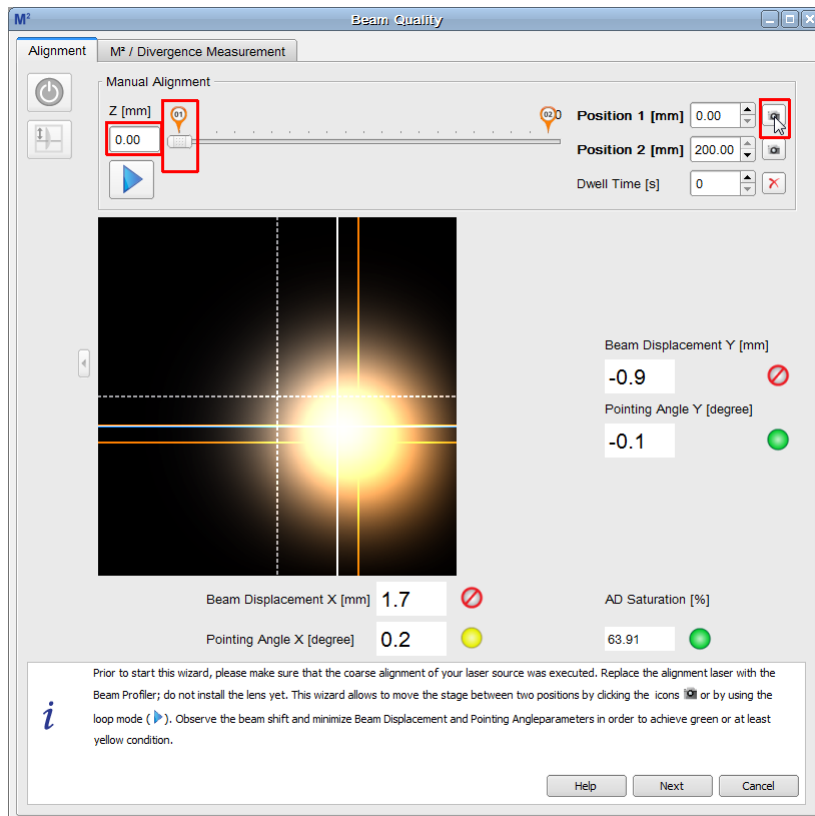

Centroid captured at Position 1

- Now, the beam displacement and the pointing angle are displayed numerically.
- Align the beam position using the controls of your laser source. Subsequently click the capture button of Position 1 and 2, observe the alignment, and improve it until all four alignment criteria are fulfilled (bulbs must be at least yellow):

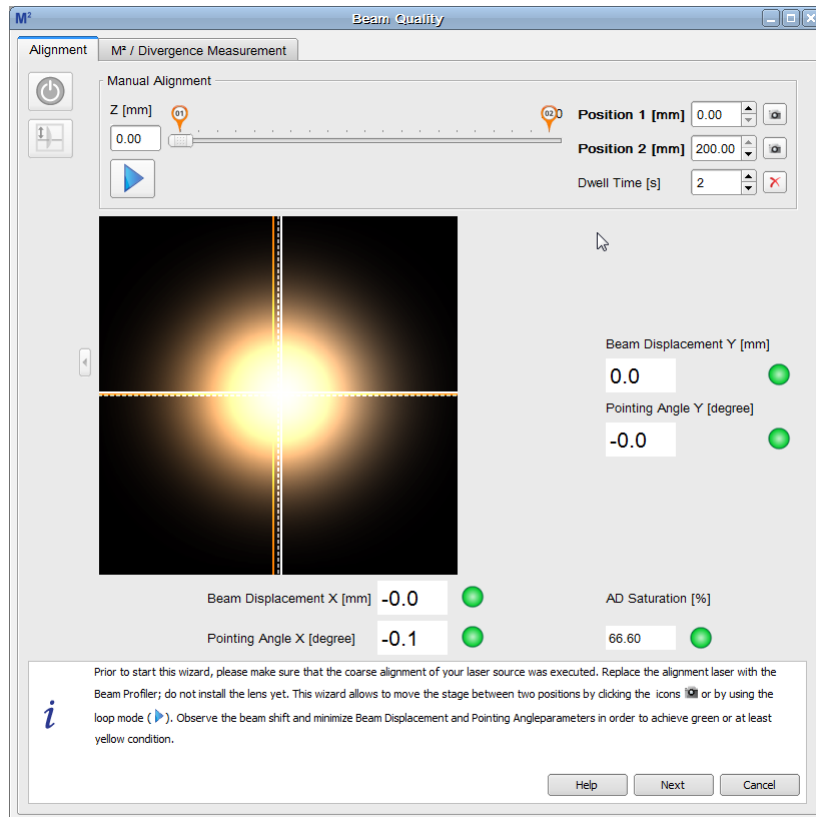

Well aligned beam position

- To toggle between the two positions, the movement of the stage between the two stop positions can be controlled automatically by the software. Just push the loop button  and enter a convenient dwell time value. The stage starts a loop move, dwelling at the stop position for the given time. During the dwelling a realignment can be made. Please keep in mind, that the numeric alignment indicators are being updated only after the next move.

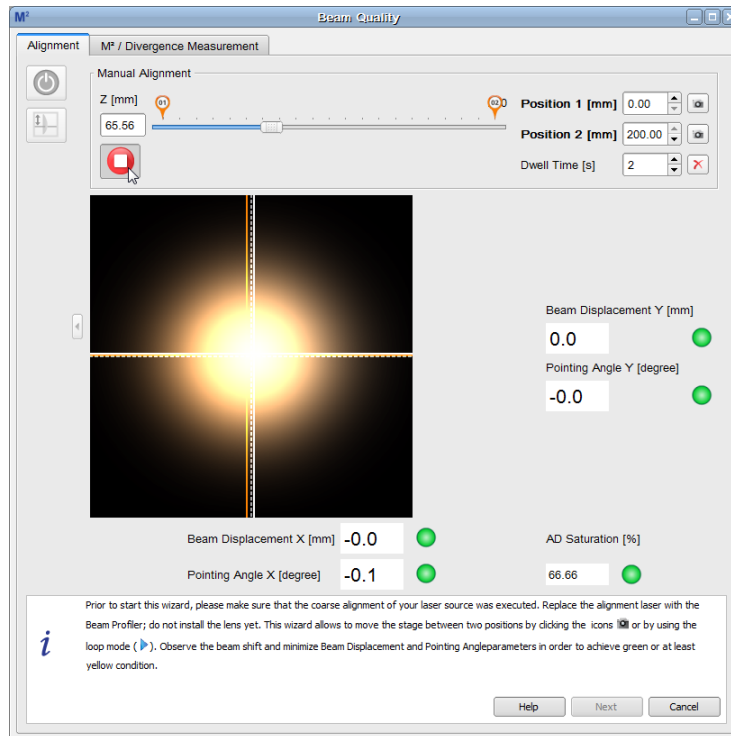
*Alignment Move Loop*

- To terminate the loop, click the  button.
- After finishing, click **Next** to continue.





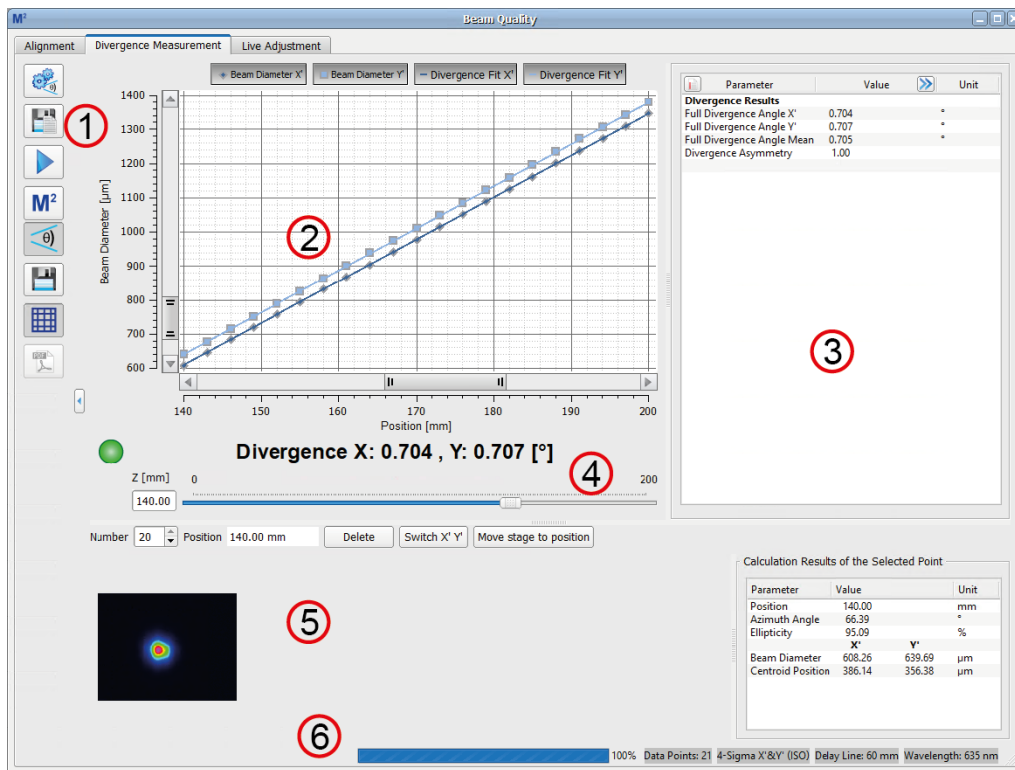



5.6.7.2 Divergence Measurement Panel

The **Divergence Measurement Panel** is derived from the M² Measurement window:



The Divergence Measurement panel is divided into 6 sub panels:

1. Toolbar

-  Divergence Settings Opens the settings for the [Divergence measurement](#) ¹³⁹
-  Auto Save Data [Save Beam Profile Data during M² Measurement](#) ¹¹⁷
-  Start / Stop Starts / stops a Divergence measurement
-  M² Switches to M² measurement
-  Divergence Switches to Divergence measurement
-  Save Data After a successful Divergence measurement this button is enabled and plot data can be saved.
-  Grid Disables/Enables the grid in the diagram
-  PDF Test Protocol Saves the results of a Divergence measurement into a PDF file

2. Divergence Diagram

The measured data are plotted in the diagram. The 4 buttons above the diagram configure the display: The buttons **Beam Diameter X' (Y')** enable / disable the display of the measured data at the individual positions. The buttons **Divergence Fit X' (Y')** enable / disable the curve fit to the measured data points.

After the measurement is finished, below the diagram the Divergence results for the X and Y axes are displayed. The indicator to the left shows if the measurement was successful.

The red marked button  between the toolbar and the diagram expands the diagram over the entire Divergence window.

3. Numeric Results

In this area, the beam quality measurement results are displayed in detail. Please see section [Divergence Measurement Results](#)^[141] for more details.

4. Position Bar

The Position Bar below the Divergence Diagram shows the actual position of the translation stage as seen before in the [Alignment](#)^[102] tab.

5. Individual Data Points

Select the **Number** of the desired measured data point in the header of this sub-panel. For this selected point, the position of stage and the the 2D projection of the beam is displayed. The table **Calculation Results of the Selected Point** to the right contains the following information:

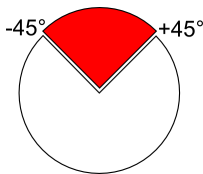
Parameter	Explanation
Position [mm]	The actual Z position of the translation stage for the selected data point.
Azimuth Angle [deg]	For 4σ beam widths the azimuth angle is the absolute azimuth angle, calculated in accordance with ISO11146-1 using the 4σ beam widths. Note that the rotation range is <u>not</u> identical to the Orientation ^[64] used for the ellipse. Rotation angle range: <div style="text-align: center; margin: 10px 0;">  </div>
Ellipticity	The ellipticity of the fitted to an ellipse beam (see Application Note ^[171]).
Beam Diameter X' [μm] Beam Diameter Y' [μm]	For 4σ beam widths these are the ISO11146 compliant 4σ beam diameters in the transformed coordinate system (not lab system) at the actual Z position. In case of ellipse clip level beam widths the shown values are the minor and major ellipse axes.
Centroid Position X' Centroid Position Y'	The positions of the beam centroids.

6. Status Bar

- Measurement progress bar
- Total number of measured data points
- Beam width setting for divergence measurement

- Delay Line: Measurement range (difference between Start and Stop positions)
- Wavelength setting (not relevant for divergence calculation)

5.6.7.3 Divergence Measurement Settings

For a successful and reliable measurement, the appropriate measurement settings are essential. Click to  to enter the **Divergence Measurement Settings**.

Beam Width

The Beam Width calculation is based on an ellipse-based approximation with two possible clip levels. At the beginning of a measurement a reference angle is determined by averaging over 10 frames. This angle is then used to evaluate all following frames and ellipses.

Measurement Parameters

The wavelength is not relevant for divergence measurement.

Measurement Range

determines the distance from the starting to the stopping point over which the sleigh is driven during the measurement. **Start** has to be at least 5 mm smaller than **Stop** and ≥ 0 mm. Valid values for Stop are

5 mm < Stop < stage length.

Note

It is advisable to set up a scan range > 40 mm to ensure higher accuracy. A scan over the entire translation length is often the best choice.

Timeout is the max. waiting time for a valid camera image. This is to allow the Auto exposure function to obtain a valid camera image

Stage Position After Scan

is not relevant for divergence measurement.

Angle Unit

Degree or milliradian can be selected.

Reset



Restores the default settings for divergence settings:

Parameter	Default Setting
Beam Width	4s Diameter (ISO Standard)
Start	0 mm
Stop	200 mm
Min. Data Points	10
Timeout	15 sec

Calculation Area

The settings for the **Calculation Area** can be made in the [Beam Settings Panel](#)^[50]. During a Beam Quality Measurement (M^2 or Divergence) the Automatic Calculation Area is enabled by default for effective noise reduction. Reflections and artifacts from filters, lenses or other optical elements can be suppressed as well using the automatic Calculation Area which is close to the beam profile.

This setting can be changed to manual, but this may affect the measurement.

By default the Clip Level of the Calculation Area is set to 1%. This is a reasonable value for most applications and measurements. Lowering the clip level leads to increased calculation area and noise level, this way increasing the measured the beam width.

Note

Setting the Clip Level of the Calculation Area for divergence measurements is not as critical as for M^2 measurements. Increasing the Clip Level will give smaller beam widths but might cut the beam profile.

Initial Settings

Independently from the user-defined settings, the following options are set automatically for every divergence measurement.

Setting	Parameter
Calculation Area	Automatic
Auto Exposure	On
Ambient Light Correction	remains as set

Note

It is strongly recommended to run an [ambient light correction](#)^[40] prior to any measurement, and then enable Ambient Light Correction.

Please be aware of the fact that ambient light correction is disabled any time the Beam Software is started and/or the settings for [attenuation](#)^[39] (filter wheel) are changed in the software.

5.6.7.4 Saving the Divergence Measurement Results

Besides the standard function "Save Divergence Measurement Results" the Thorlabs Beam Software offers an automatic saving of beam profile data when a Divergence measurement is executed.

For details, please see section [Saving the \$M^2\$ Measurement Results](#)^[116].

Note

The Divergence measurement results cannot be saved as PDF Test Protocol, only as CSV, TXT or XLS files.

5.6.7.5 Running the Divergence Measurement

The divergence measurement is designed to measure low divergent or convergent beam propagation. Therefore, the measurement requires removing any focusing elements which produce a beam waist within the scan range.

Prior to starting the measurement, make sure that:

- The beam is aligned properly - it should ideally remain centered with respect to the sensor center over the entire scan range. See chapter [Beam Alignment](#)^[129] for aligning the beam.
- The ambient light is turned off or dimmed as far as possible. Ambient light may disturb the measurement and should be avoided.
- Reflections and interferences are avoided as far as possible.
- ~~The laser system is warmed up - depending on the source this might take up to 1 hour.~~

- The laser output is spatially and temporally stable.

Start the measurement by clicking the **Start** button .

While running the measurement, most of the buttons and options are disabled, e.g. the Divergence measurement settings and the toolbar. This prevents the modification of settings during a measurement.

If necessary, the measurement can be interrupted by clicking the **Stop** button .

After starting the measurement the X axis of the graph is adapted to the user-defined scan range, for example from 0 to 120 mm. The Y axis scales automatically to the recorded beam widths.

5.6.7.6 Divergence Measurement Results

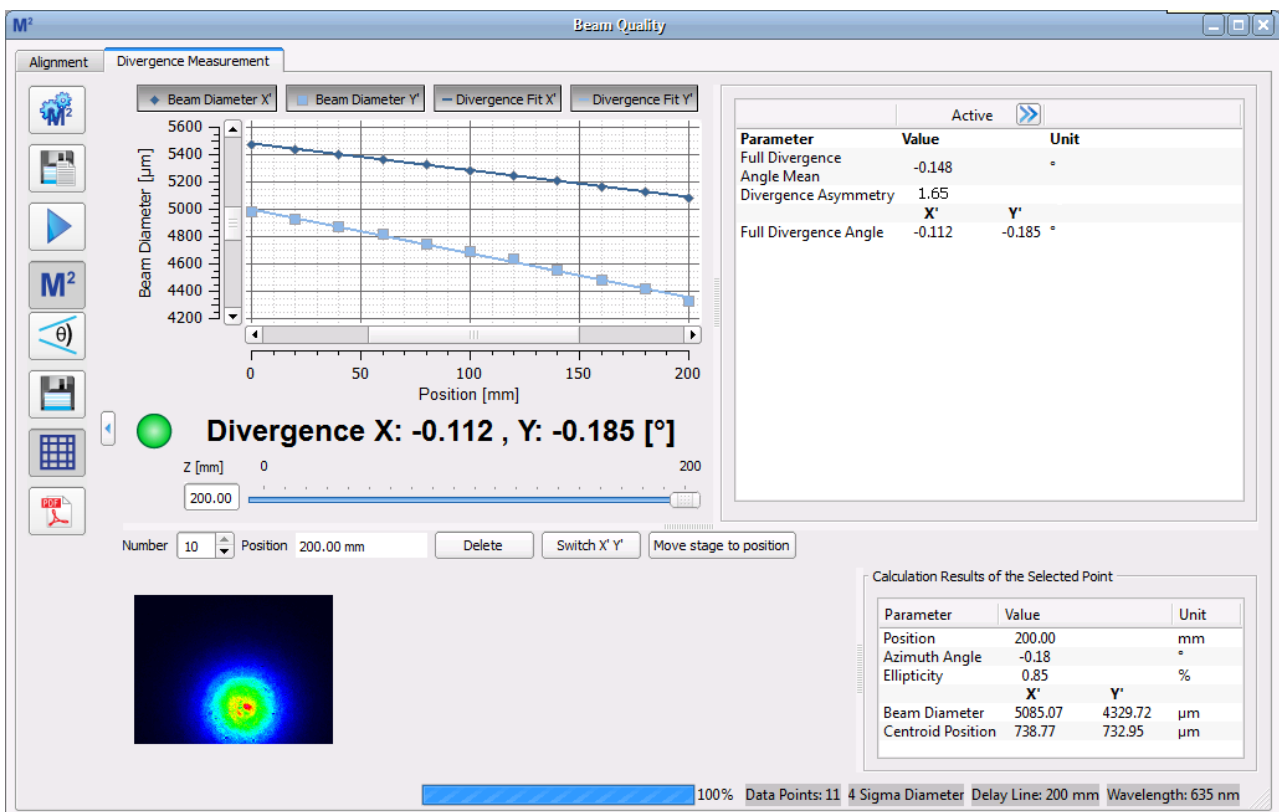

The green bulb indicates that the measurement was successful.

 **Divergence X: -0.112, Y: -0.185 [°]**

These values can also be found in the listing of the complete **Results**.

Parameter	Value	Unit
Full Divergence Angle Mean	-0.148	°
Divergence Asymmetry	1.65	
Full Divergence Angle	-0.112	-0.185 °

Negative values indicate a converging beam, while positive values indicate a diverging beam.

Note

All results are calculated from the applied linear fit!

Full Divergence Angle X' (Y') is explained in chapter [M² Theory](#)^[143].

Divergence Asymmetry Asymmetry is the quotient of divergence angles in Y and X scan directions. Values differing from 1.0 indicate that the beam ellipticity is changing with z position, for instance an elliptical beam is focused to a round spot.

$$\text{divergence asymmetry} = \frac{\theta_y}{\theta_x}$$

Reference Measurement

The actual measurement results can be saved and used as reference afterwards, same as for [M² Measurement Results](#)¹²⁴.

5.6.7.7 Live Adjustment

As for the M² Measurement, the Divergence Measurement Panel also offers the option for a Live Adjustment of the laser system.

Open the Live Adjustment panel and click "start" to move the M2 stage to the lens focus plane as calculated from the inserted parameters. Now, the laser system can be adjusted and, for example, collimation can be optimized until the beam width in the focus plane is minimized.

As the stage moves to the focal plane, the Z-slider on the bottom right moves under the lens focus (LF) icon.

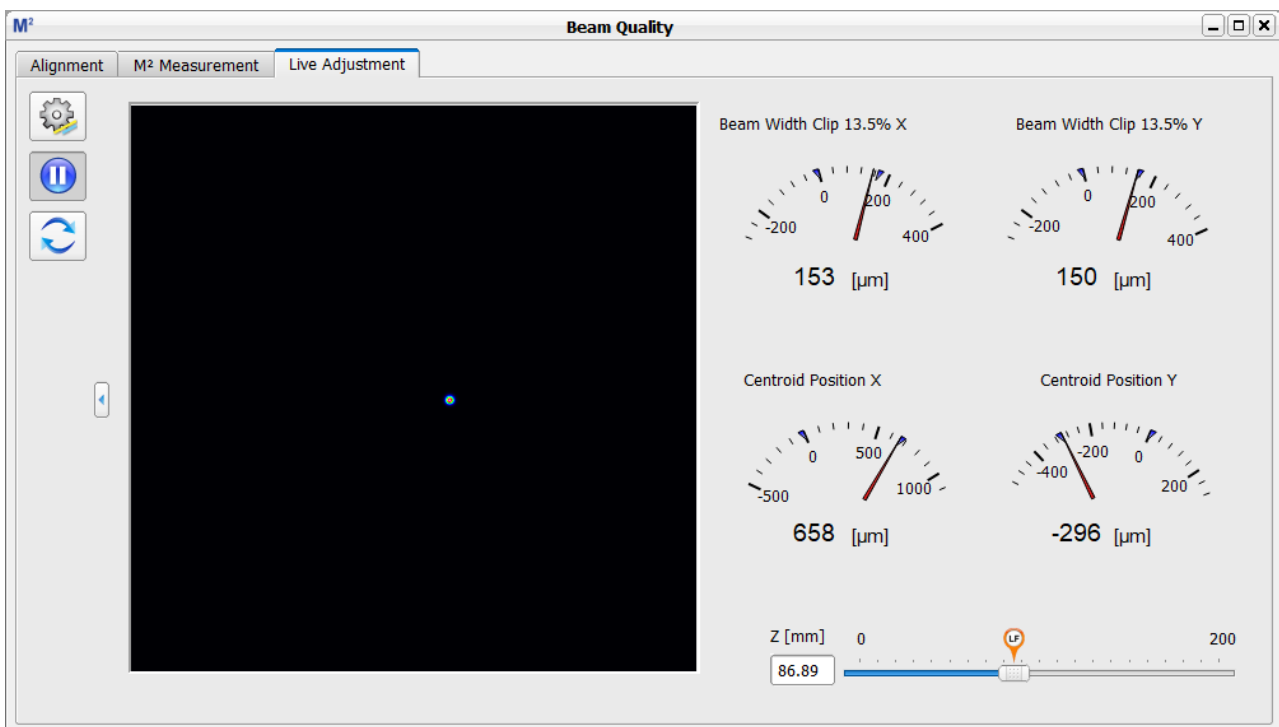

The right panel shows the Beam Width and Centroid Position in X and Y.

Beam Width: The displayed beam width is calculated based on the settings chosen in the Settings Panel of this window opened through the icon on the left.

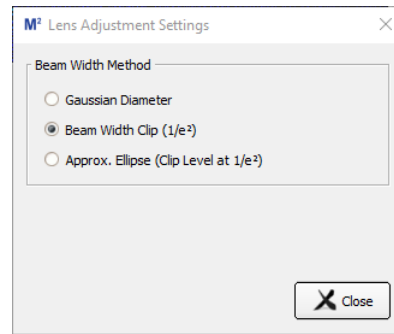

Centroid Position: The Centroid position is displayed to maintain knowledge of the beam position during adjustment.

Adjustment in Z is facilitated by the slider on the bottom right.

5.6.8 M² Theory

The diameter $d(z)$ of a focused laser beam increases with distance z from its waist position and can be calculated as follows:

$$d(z) = d_0 \sqrt{1 + \left(\frac{z}{z_R}\right)^2}$$

with

- d_0 Waist Diameter
- z_R Rayleigh Length
- l Wavelength

In this equation it was assumed that the waist location is at zero. Otherwise z has to be replaced with $(z-z_0)$

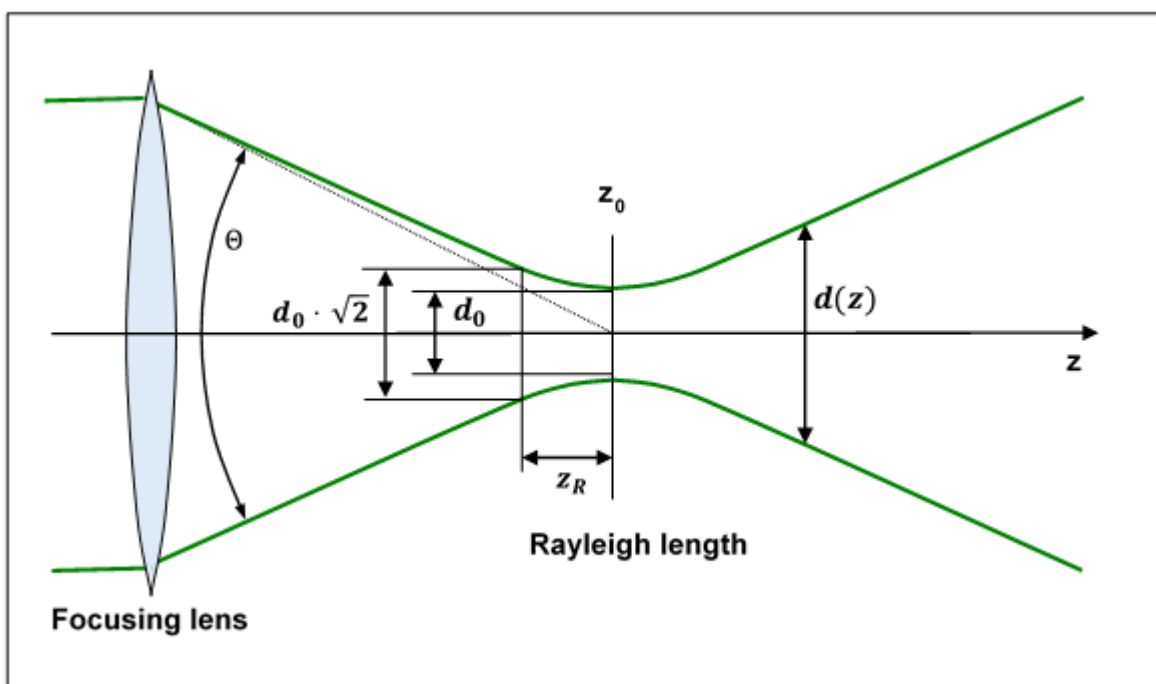

The Rayleigh Length z_R determines the distance from the beam waist to the position where the beam diameter has increased by a factor of $\sqrt{2} = 1.41$ compared to the minimum diameter at the waist.

From the equation for $d(z)$ it can be seen that the beam diameter increases linearly with z in the far field ($z \gg z_R$). The full divergence angle Θ can be calculated by

$$\Theta \approx \frac{d(z; z \gg z_R)}{z} = \frac{d_0}{z_R}$$

For laser beams with fundamental mode TEM₀₀ (Gaussian Beam shape) it can be theoretically shown that the Rayleigh Length is given by

$$z_{RG} = \frac{\pi d_{0G}^2}{4\lambda}$$

Thus the product of the minimum diameter of a Gaussian beam (at waist) and the divergence angle $d_{0G} \cdot \Theta_G$ (AKA 'Beam Parameter Product', BPP) is constant for a given wavelength:

$$d_{0G} \Theta_G = \frac{4\lambda}{\pi}$$

For mode mixture (MM) beams, i.e. beams which feature higher order modes than just the fundamental mode TEM₀₀, the product of beam diameter and divergence increases by a factor of M^2 .

$$d_{0MM} \Theta_{MM} = M^2 d_{0G} \Theta_G = M^2 \frac{4\lambda}{\pi}$$

Finally, the times-diffraction-limit factor M^2 is calculated by

$$M^2 = \frac{\pi}{4\lambda} d_{0MM} \Theta_{MM}$$

The Rayleigh Length is now given by

$$z_{RMM} = \frac{\pi d_{0MM}^2}{M^2 \lambda}$$

The reciprocal of the times-diffraction-limit factor M^2 is called the beam propagation factor or beam quality K .

$$K = \frac{1}{M^2}$$

The following table illustrates the differences between a perfect Gaussian beam and non-perfect beam.

Parameter	Gaussian Beam	Mode Mixture Beam
Times-diffraction-limit factor M^2	1	> 1
Beam propagation factor = Beam quality K	1	< 1
Beam waist for given lens	minimal	larger
Divergence angle q at given beam waist d_0	narrow	wider

Reasons for Non-Ideal Gaussian Beam with $M^2 > 1$

Using a Gaussian beam is preferred because of its minimum divergence angle and the ability to achieve the minimal focus diameter. Differences to Gaussian shape can be due to

- existence of higher order modes
- amplitude and phase distortions due to inhomogeneous gain medium in lasers
- presence of extraordinary beams

These distortions lead to a larger beam waist compared to Gaussian beams when the same focal lens is used. This results in a lower maximum achievable power density in the focal point.

Comparison of Propagation Between Fundamental Mode TEM₀₀ (Ideal Gaussian beam) and Mode Mixture Beams

With a given divergence angle (i.e. knowing the focal length of the lens), the fundamental mode alone produces the theoretically smallest possible beam waist (green curve). If beam quality worsens (red curve), the beam waist increases. If divergence is fixed, beam waist increases linearly by the factor M² compared to the underlying Gaussian.

$$d_{0MM}(\theta_{MM} = \theta_G) = M^2 \cdot d_{0G}$$

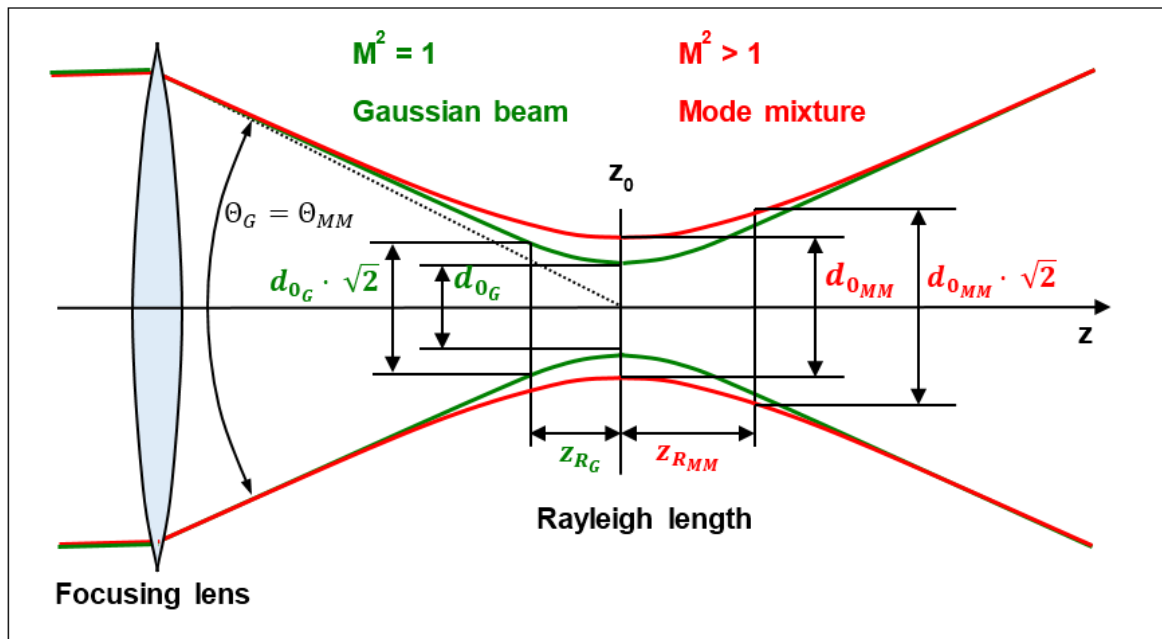

The appropriate power density at z₀ is reduced by a factor (M²)². Also the Rayleigh Length increases by a factor of M².

$$z_{RMM}(\theta_{MM} = \theta_G) = \frac{\pi d_{0MM}^2}{M^2 \cdot 4\lambda} = M^2 \frac{\pi d_{0G}^2}{4\lambda} = M^2 \cdot z_{RG}$$

Chapter 6 Write Your Own Application

In order to write your own application, you need a specific instrument driver and some tools for use in different programming environments. The driver and tools are being installed to your computer during software installation and cannot be found in the installation package.

In this section the location of drivers and files, required for programming in different environments, are given for installation under Windows® 8.1 (32 and 64 bit), Windows® 10 (32 and 64 bit) and Windows® 11.

In order to fully support 64 bit LabView version, the installation package provides two installer components, the 32 bit and the 64 bit component:

- for Windows® 8.1 (32/64 bit), Windows® 10 (32/64 bit) and Windows® 11: Install "Thorlabs Beam VXIpn Instrument Driver (32bit)"
- for Windows® 8.1 (64 bit), Windows® 10 (64 bit) and Windows® 11 : Install "Thorlabs Beam VXIpn Instrument Driver (64 bit)"

In other words, the 32 bit VXIpn driver works with both 32 and 64 bit operating systems, while the 64 bit driver requires a 64 bit operating system.

Note

The Beam Software and drivers contains 32 bit and 64 bit applications.

In 32 bit systems, only the 32 bit components are installed to

C:\Program Files\...

In 64 bit systems the 64 bit components are being installed to

C:\Program Files\...

while 32 bit components can be found at

C:\Program Files (x86)\...

In the table below you will find a summary of what files you need for particular programming environments.

Programming environment	Necessary files
C, C++, CVI	*.h (header file) *.lib (static library)
C#	.net wrapper dll
Visual Studio	*.h (header file) *.lib (static library) or .net wrapper dll
LabView	*.fp (function panel) and VXIpn Instrument Driver. Beside that, LabVIEW driver vi's are provided with the *.llb container file. Note: LabVIEW drivers and components are installed only, if a LabVIEW installation was recognized.
Python	*.py wrapper

Note

All above environments require also the VXIpn Instrument Driver dll !

During NI-VISA Runtime installation, a system environment variable VXIPNPPATH for including files is created. It contains the information where the drivers are installed to, usually to C:\Program Files\IVI Foundation\VISA\WinNT\.

This is the reason, why after installation of a NI-VISA Runtime a system reboot is required: This environment variable is necessary for installation of the instrument driver software components.

In the next sections the locations of above files are described in detail.

6.1 32 bit Operating System

Note

According to the VPP6 (Rev6.1) Standard the installation of the 32 bit VXIpnP driver includes both the WINNT and GWINNT frameworks.

VXIpnP Instrument driver:

```
C:\Program Files\IVI Foundation\VISA\WinNT\Bin\TLBC2_32.dll
```

Note

This instrument driver is required for all development environments!

Header file

```
C:\Program Files\IVI Foundation\VISA\WinNT\include\TLBC2.h
```

Static Library

```
C:\Program Files\IVI Foundation\VISA\WinNT\lib\msc\TLBC2_32.lib
```

Function Panel

```
C:\Program Files\IVI Foundation\VISA\WinNT\TLBC2\TLBC2.fp
```

Online Help for VXIpnP Instrument driver:

```
C:\Program Files\IVI Foundation\VISA\WinNT\TLBC2\Manual\TLBC2.html
```

NI LabVIEW driver

The LabVIEW Driver is a 32 bit driver and compatible with 32bit NI-LabVIEW 2018 and higher only.

```
C:\Program Files\National Instruments\LabVIEW xxxx\Instr.lib\TLBC2...  
...\TLBC2.llb
```

(LabVIEW container file with driver vi's and an example. "LabVIEW xxxx" stands for actual LabVIEW installation folder.)

.net wrapper dll

```
C:\Program Files\Microsoft.NET\Primary Interop Assemblies...  
...\Thorlabs.TLBC2_32.Interop.dll
```

```
C:\Program Files\IVI Foundation\VISA\VisaCom\...  
...\Primary Interop Assemblies\Thorlabs.TLBC2_32.Interop.dll
```

Python wrapper

C:\Program Files\IVI
Foundation\VISA\WinNT\TLBC2\Examples\Python\TLBC2.py

Example for C**Project file:**

C:\Program Files\IVI Foundation\VISA\WinNT\TLBC2\Examples\
... CVI C Sample\TLTSI_CSample.prj

Source file:

C:\Program Files\IVI Foundation\VISA\WinNT\TLBC2\Examples\
... CVI C Sample\sample.c

Example for C#**Solution file:**

C:\Program Files\IVI Foundation\VISA\WinNT\TLBC2\Examples\
...\MS VS 2012 CSharp Demo\BC2_CSharpDemo.sln

Project file:

C:\Program Files\IVI Foundation\VISA\WinNT\TLBC2\Examples ...
...\MS VS 2012 CSharp Demo\BC2_CSharpDemo\BC2_CSharpDemo.csproj

Example for LabVIEW

C:\Program Files\National Instruments\LabVIEW xxxx\Instr.lib\TLBC2...
...\TLBC2.llb

(LabVIEW container file with driver vi's and an example. "LabVIEW xxxx" stands for actual LabVIEW installation folder.)

Example for Python**Solution File:****Python wrapper**

C:\Program Files\IVI
Foundation\VISA\WinNT\TLBC2\Examples\Python\TLBC2_Sample.py

6.2 64 bit Operating System

Note

According to the VPP6 (Rev6.1) Standard the installation of the 64 bit VxIpnP driver includes the WINNT, WIN64, GWINNT and GWIN64 frameworks. That means, that the 64 bit driver includes the 32 bit driver as well.

In case of a 64 bit operating system, 64bit drivers and applications are installed to

```
"C:\Program Files"
```

while the 32 bit files - to

```
"C:\Program Files (x86)"
```

Below are listed both installation locations, so far applicable.

VxIpnP Instrument driver:

```
C:\Program Files (x86)\IVI Foundation\VISA\WinNT\Bin\TLBC2_32.dll
```

```
C:\Program Files\IVI Foundation\VISA\Win64\Bin\TLBC2_32.dll
```

```
C:\Program Files\IVI Foundation\VISA\Win64\Bin\TLBC2_64.dll
```

Note

This instrument driver is required for all development environments!

Header file

```
C:\Program Files (x86)\IVI Foundation\VISA\WinNT\include\TLBC2.h
```

```
C:\Program Files\IVI Foundation\VISA\Win64\include\TLBC2.h
```

Static Library

```
C:\Program Files (x86)\IVI Foundation\VISA\WinNT\lib\msc...  
...\TLBC2_32.lib
```

```
C:\Program Files\IVI Foundation\VISA\Win64\lib\msc\TLBC2_32.lib
```

```
C:\Program Files\IVI Foundation\VISA\Win64\Lib_x64\msc\TLBC2_64.lib
```

Function Panel

```
C:\Program Files (x86)\IVI Foundation\VISA\WinNT\TLBC2\TLBC2.fp
```

Online Help for VxIpnP Instrument driver:

```
C:\Program Files (x86)\IVI Foundation\VISA\WinNT\TLBC2\...  
...Manual\TLBC2.html
```

NI LabVIEW driver

The LabVIEW Driver supports 32bit and 64bit NI-LabVIEW2018 and higher.

```
C:\Program Files\National Instruments\LabVIEW xxxx\Instr.lib\TLBC2...
...\TLBC2.llb
```

(LabVIEW container file with driver vi's and an example. "LabVIEW xxxx" stands for actual LabVIEW installation folder.)

.net wrapper dll

```
C:\Program Files (x86)\Microsoft.NET\Primary Interop Assemblies...
...\Thorlabs.TLBC2_32.Interop.dll
```

```
C:\Program Files (x86)\IVI Foundation\VISA\VisaCom\...
...\Primary Interop Assemblies\Thorlabs.TLBC2_32.Interop.dll
```

```
C:\Program Files\IVI Foundation\VISA\VisaCom64\...
...\Primary Interop Assemblies\Thorlabs.TLBC2_64.Interop.dll
```

Python wrapper

```
C:\Program Files (x86)\IVI
Foundation\VISA\WinNT\TLBC2\Examples\Python\TLBC2.py
```

Example for C

Project file:

```
C:\Program Files (x86)\IVI Foundation\VISA\WinNT\TLBC2\Examples\...
... CVI C Sample\TLBC2_CSample.prj
```

Source file:

```
C:\Program Files (x86)\IVI Foundation\VISA\WinNT\TLBC2\Examples\...
... CVI C Sample\sample.c
```

Example for C#

Solution file:

```
C:\Program Files (x86)\IVI Foundation\VISA\WinNT\TLBC2\Examples...
...\MS VS 2012 CSharp Demo\BC1_CSharpDemo.sln
```

Project file:

```
C:\Program Files (x86)\IVI Foundation\VISA\WinNT\TLBC2\Examples ...
...\MS VS 2012 CSharp Demo\BC1_CSharpDemo\BC1_CSharpDemo.csproj
```

Example for LabView

C:\Program Files\National Instruments\LabVIEW xxxx\Instr.lib\TLBC2...
...\TLBC2.llb

(LabVIEW container file with driver vi's and an example. "LabVIEW xxxx" stands for actual LabVIEW installation folder.)

Example for Python

Solution File:

Python wrapper

C:\Program Files (x86)\IVI
Foundation\VISA\WinNT\TLBC2\Examples\Python\TLBC2_Sample.py

Chapter 7 Specifications BC207x and BC210Cx

Item #	BC207UV(/M)	BC207VIS(/M)	BC210CU(/M)	BC210CV(/M)
Camera Beam Profiler Specifications				
Wavelength Range	245 - 400 nm ¹⁾	350 - 1100 nm	245 - 400 nm ¹⁾	350 - 1100 nm
Power Range	20 fW - 1 W ^{2,3)}	40 fW - 1 W ^{3,4)}	20 fW - 1 W ^{2,3)}	40 fW - 1 W ^{3,4)}
Beam Diameter	20 μ m - 7.0 mm		20 μ m - 10.0 mm	
Compatible Light Sources	CW, Pulsed ⁵⁾		CW, Pulsed ⁵⁾	
Protection Glass	WG41010-UV	\varnothing 25 mm NG3 absorptive ND filter, t = 1 mm, nominal Optical Density: 1.0	WG41010-UV	\varnothing 25 mm NG3 absorptive ND filter, t = 1 mm, nominal Optical Density: 1.0
Absorptive Neutral Density Filters				
Nominal Attenuation Values	20 dB, 30 dB, 40 dB ⁶⁾	20 dB, 40 dB, 60 dB, Two Sets ⁷⁾	20 dB, 30 dB, 40 dB ⁶⁾	20 dB, 40 dB, 60 dB, Two Sets ⁷⁾
AR Coating Wavelength Range	No AR Coating Available	350 - 700 nm (Three Filters) 650 - 1050 nm (Three Filters)	No AR Coating Available	350 - 700 nm (Three Filters) 650 - 1050 nm (Three Filters)
Reflective Neutral Density Filters				
Nominal Attenuation Values	20 dB, 30 dB, 40 dB	NA	20 dB, 30 dB, 40 dB	NA
Sensor				
Chip	Sony IMX264LLR, Windowless 11.1 mm Diagonal, 5.0 MP		Sony IMX304LLR, Windowless 17.5 mm Diagonal, 12.3 MP	
Aperture Size (Max)	8.45 mm x 7.07 mm		14.13 mm x 10.32 mm	
Pixel Size	3.45 μ m x 3.45 μ m		3.45 μ m x 3.45 μ m	
Resolution, max.	2448 x 2048 pixel, ROI Selectable		4096 x 2992 pixel, ROI Selectable	
Camera				
Shutter	Global		Global	
Binning	1 x 1; 2 x 2; 4 x 4; 8 x 8; 16 x 16		1 x 1; 2 x 2; 4 x 4; 8 x 8; 16 x 16	
Frame Rate (Max) @ Full Resolution	4 fps ⁸⁾		1.5 fps ⁸⁾ (Max)	
Frame Rate @ 1224 x 1024 pix	>8 fps ⁸⁾		>8 fps ⁸⁾	

Item #	BC207UV(/M)	BC207VIS(/M)	BC210CU(/M)	BC210CV(/M)
Frame Rate @ 612 x 512 pix	>12 fps ⁸⁾		>12 fps ⁸⁾	
Pulse Frequency	up to 37 kHz (Single Pulse Detection) Unlimited (Multi Pulse Detection) ⁹⁾		up to 37 kHz (Single Pulse Detection) Unlimited (Multi Pulse Detection) ⁹⁾	
Image Digitization	12 bit		12 bit	
Signal-to-Noise Ratio	≤ 71 dB		≤ 71 dB	
Exposure Range	27 μs – 1 s		25 μs – 500 ms	
Gain Range	0 - 12 dB		0 - 12 dB	
Image Capture Modes	Single Frame, Continuous, Hardware Triggered		Single Frame, Continuous, Hardware Triggered	
Sensor Distance to Front (Filter Holder Surface)	20.7 mm (0.82")		20.3 mm (0.80")	
Interfaces				
Trigger Input	TTL Level, LVTTTL compatible, BNC Jack, Low: 0 to +0.4 V High: 2.4 V to 5.5. V, BNC Jack ¹⁰⁾		TTL Level, LVTTTL compatible, SMA Jack, Low: 0 to +0.4 V High: 2.4 V to 5.5. V, SMA Jack ¹⁰⁾	
Trigger Delay	0.27 μs		0.27 μs	
Pulse Width (Min)	100 μs		100 μs	
PC Interface	USB 3.0 (Micro B)		USB 3.0 (Micro B)	
Item #	BC207UV(/M), BC207VIS(/M)		BC210CU(/M) and BC210CV(/M)	
General				
Operating Temperature	10 °C to 35 °C		10 °C to 35 °C	
Storage Temperature	0 °C to 55 °C		0 °C to 55 °C	
Size (H x W x D) Including Filter Wheel	94.3 mm x 84.8 mm x 85.7 mm (3.71" x 3.34" x 3.37")		95.8 mm x 88.4 mm x 34.7 mm (3.77" x 3.48" x 1.37")	
Weight	420 g		300g	
Mounting Holes, Imperial Version	1/4"-20			
Mounting Holes, Metric Version	M6 x 1 mm			
Power Supply	3.6 W, USB Bus Powered		3.9 W, USB Bus Powered	

- 1) The wavelength range of the supplied UV ND filters starts at 200 nm, see chapters [Filter Wheel](#)⁹
 - 2) @ 400 nm depending on beam diameter and ND filter.
 - 3) The neutral density filter will begin to heat up and can be damaged if exposed to incident powers above 1 W for more than a few seconds.
 - 4) @ 700 nm depending on beam diameter and ND filter.
 - 5) Damage threshold data is currently not available for the BC207 and BC210C beam profilers. For applications with pulsed lasers, we recommend the following procedure as a guideline for determining a safe upper limit: Set the beam profiler to the maximum integration time (i.e., set the exposure to 1 s). Slowly increase the power until your signal reaches approximately 50% of the intensity as shown in the profile window of the Beam Software package. Multiply this power by a factor of 10. This is the safe upper limit of the mean pulse power for the beam profiler.
 - 6) These filters are provided for use near the 400 nm upper wavelength range of the BC207UV(/M) and BC210CU(/M). See the chapter [Filter Wheel](#)¹⁵⁷ for more information.
 - 7) One set of filters is AR coated for the 350 nm to 700 nm range while the other is AR coated for the 650 nm to the 1050 nm range. See the chapter [Filter Wheel](#)¹⁵⁷ for more information.
 - 8) Highly dependent on PC processor, graphic adapter performance, and size of calculation area.
 - 9) In Multi Pulse Detection, single pulses are not distinguished.
 - 10) See chapter [Trigger Input](#)¹⁵ for detailed data.
- All technical data are valid at $23 \pm 5^\circ\text{C}$ and $45 \pm 15\%$ rel. humidity.

7.1 Dimensions BC207UV(/M) and BC207VIS(/M)

The outer dimensions of all BC207 Series models are identical. They only differ by the protection glass (UV or VIS) and the filters in the filter wheel. Imperial version have 1/4"-20 tapped mounting holes while metric devices have M6 x 1.0 tapped mounting holes.

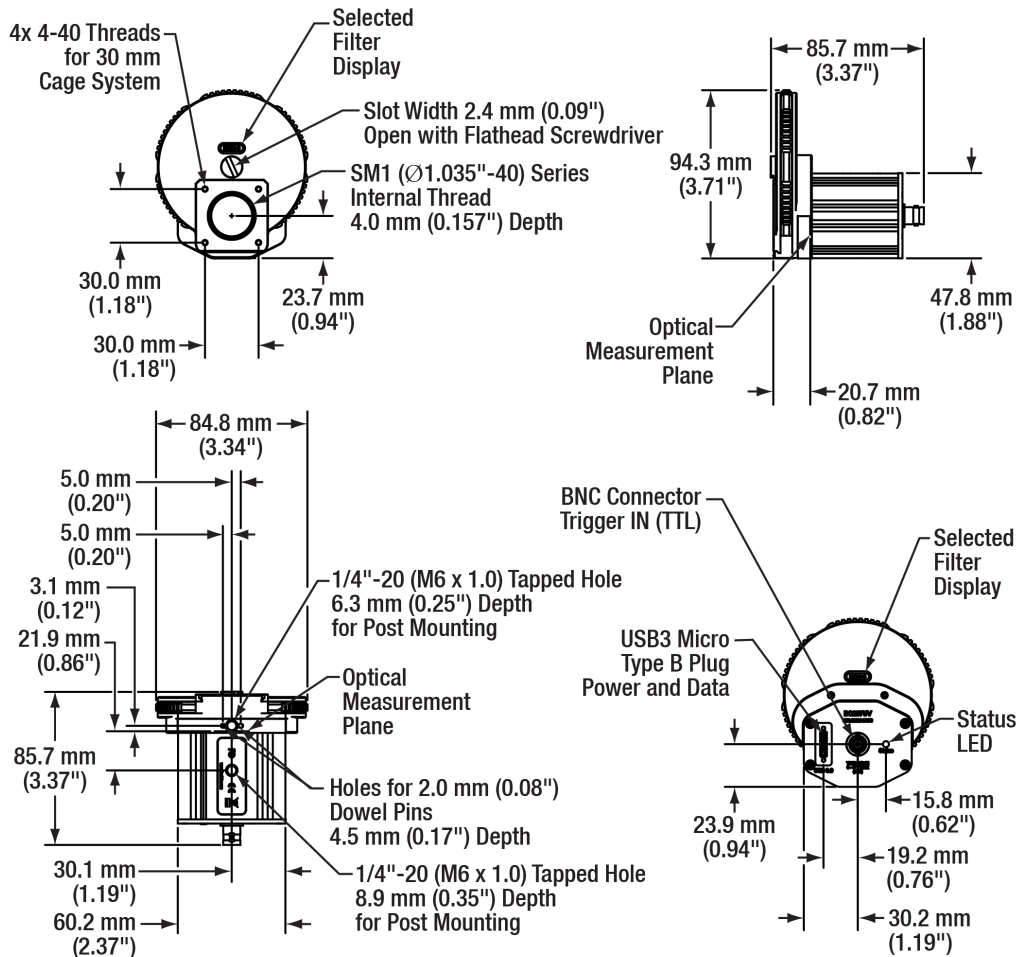

7.2 Dimensions BC210CU(/M) and BC210CV(/M)

The outer dimensions of all BC210C Series models are identical. They only differ by the protection glass (UV or VIS) and the filters in the filter wheel. Imperial version have 1/4"-20 tapped mounting holes while metric devices have M6 x 1.0 tapped mounting holes.

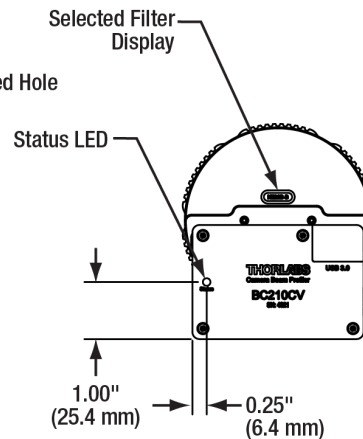
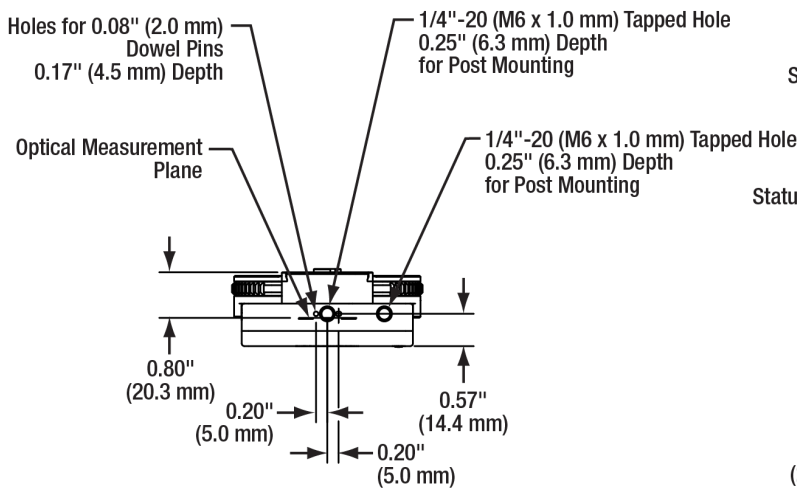
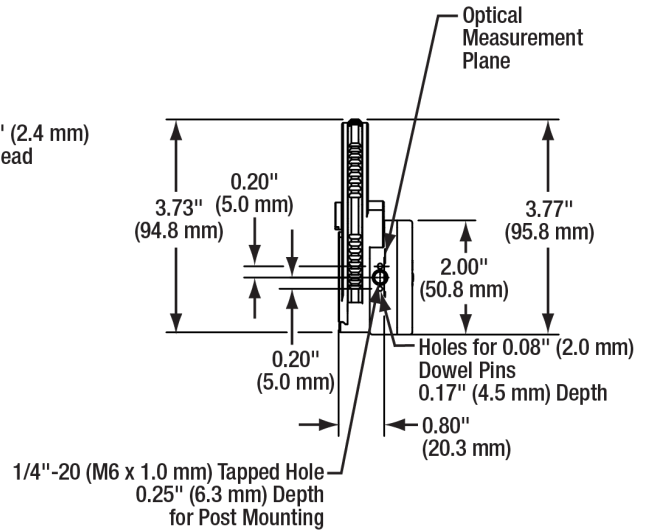
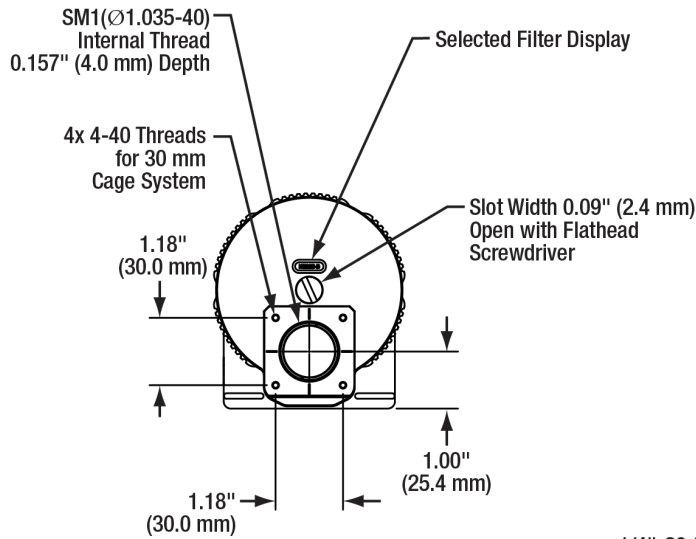

7.3 Specifications Filter Wheel

This chapter lists the optical density filters mounted in the filter wheel, and their characteristics.

BC207UV(/M) and BC210CU(/M)	
Name on Filter Wheel	Filter Type
NDUV20B	20 dB UV Fused Silica Reflective ND Filter, 200 nm - 1200 nm
NDUV30B	30 dB UV Fused Silica Reflective ND Filter, 200 nm - 1200 nm
NDUV40B	40 dB UV Fused Silica Reflective ND Filter, 200 nm - 1200 nm
NE20B	20 dB UV Absorptive ND Filter, 400nm - 650 nm ¹
NE30B	30 dB UV Absorptive ND Filter, 400nm - 650 nm ¹
NE40B	40 dB UV Absorptive ND Filter, 400nm - 650 nm ¹

¹These filters are provided for use near the 400 nm upper wavelength range of the BC207UV(/M) and BC210CV(/M).

BC207UV(/M) and BC210CU(/M)	
Name on Filter Wheel	Filter Type
NE20B-A	20 dB Absorptive ND Filter, AR-Coated: 350-700 nm
NE40B-A	40 dB Absorptive ND Filter, AR-Coated: 350-700 nm
NE60B-A	60 dB Absorptive ND Filter, AR-Coated: 350-700 nm
NE20B-B	20 dB Absorptive ND Filter, AR-Coated: 650-1050 nm
NE40B-B	40 dB Absorptive ND Filter, AR-Coated: 650-1050 nm
NE60B-B	60 dB Absorptive ND Filter, AR-Coated: 650-1050 nm

7.4 Wavelength Response

1. Wavelength Dependent Sensitivity of BC207 and BC210C Models

The following diagrams show the typical relative wavelength response of both BC207 and BC210C series models.

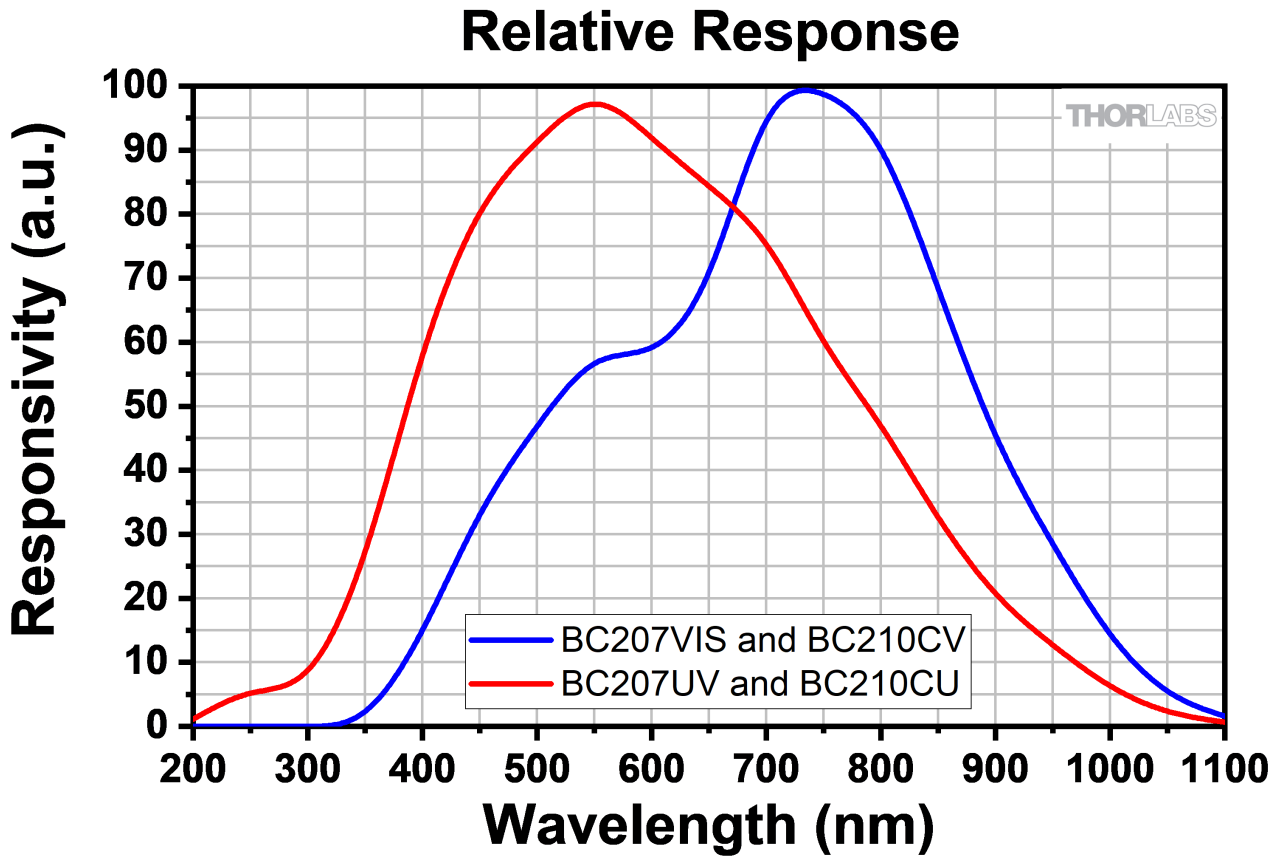

Both responsivity diagrams are measured without any ND Filter.

7.5 Power Ranges

The model BC207VIS and BC210CV has a maximum responsivity at 550 nm, BC207UV and BC210CU at 200 nm. The diagram below refers to the wavelength 400 nm for BC207UV(/M) or BC210CU(/M) and 700 nm for BC207VIS(/M) or BC210CV(/M).

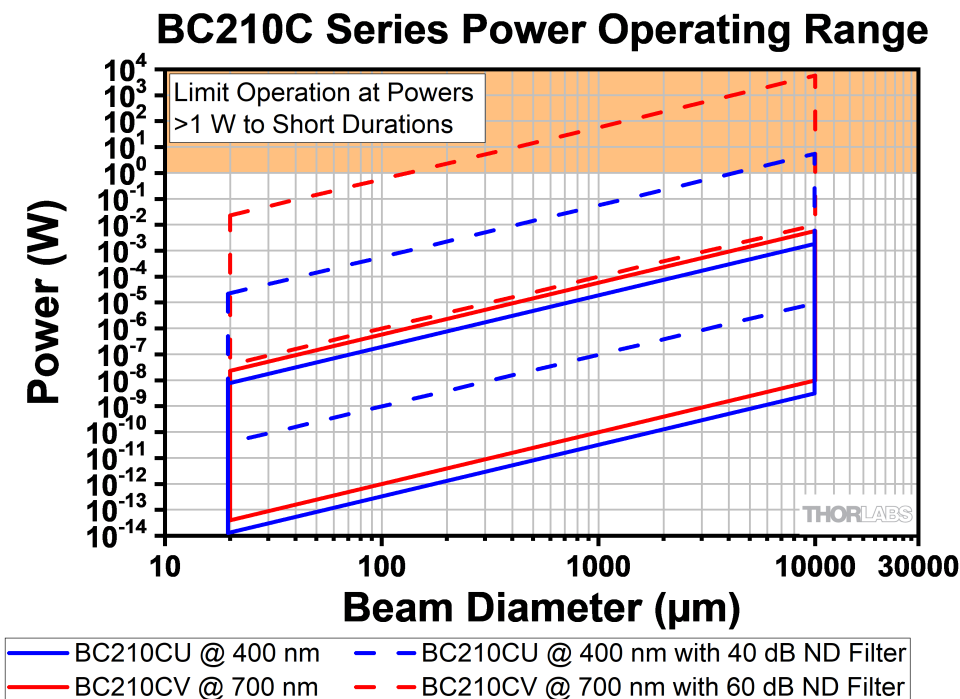
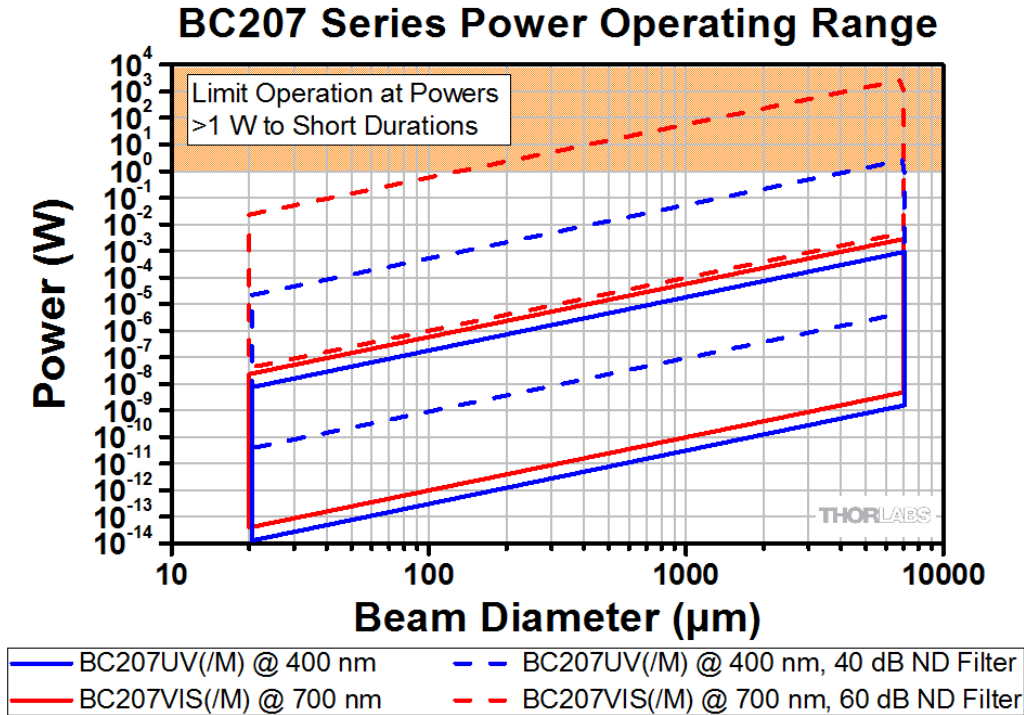

The range within the unbroken boundary lines indicate the BC207 and BC210C power range without any filter. The operating power range is shifted towards higher values when a filter is used. The range within the dashed boundary lines stands for the highest attenuation that is available from the filter wheel (40 dB for BC207UV or BC210CU; 60 dB for BC207VIS or BC210CV). With other filter settings, the power range is located between unbroken and dashed lines.

The max. and min. applicable power strongly depends on the actual beam diameter. As for this reason, first find the beam diameter on the horizontal axis of the corresponding beam profiler diagram. Then, read out the operating power range and filter setting.

Note

Please note that the above diagram represents the operating power range at the specified wavelength. For different wavelengths the power range shifts towards higher values and thus, needs to be adopted according to the wavelength depending [response curve of the sensor](#)¹⁵⁸.

Chapter 8 Specifications M2MS Extension Sets

Item #	M2MS	M2MS-AL
M2MS Extension Set General Specifications		
Wavelength Range	400-2700 nm ¹⁾	250-600nm ¹⁾
Beam Profiler Compatibility	BC207 series, BP209 series and BC210C series	
Translation Stage	DDS100/M	
Travel Range	100mm	
Velocity (Max)	500 mm/s	
Effective Translation Range	200 mm, -100 mm to +100 mm from Focal Point	
Lens Focal Length	250 mm	
Optical Axis Height	70 mm (without additional feet)	
M ² Measurement Range	1.0 - No Upper Limit	
Typical M ² Accuracy	±5 %, Depending on Optics and Alignment	
Minimum Detectable Divergence Angle	<0.1 mrad	
Applicable Light Sources	CW, Pulsed	
Size	300 mm x 175 mm x 109mm (without Beam Profiler)	
Typical Measurement Time	15 - 30 s, Depending on Beam Shape and Settings	

¹⁾ Depending on the Beam Profiler Type

Chapter 9 Initial Software Settings

When the BC207 or BC210C is used first time with the Beam software, the following initial settings are applied:

Parameter	Default value
Region Of Interest	Full Size
Tab Beam Profiler Parameter	
Wavelength	635nm
Filter Wheel Selection [dB]	No Filter (0 dB)
Auto Exposure Control	ON
Gain	1.0 (minimum)
Tab Corrections	
Hot Pixel Correction	ON
Power Correction	OFF, factory calibration active
Ambient Light Correction	OFF
Tab Trigger	
No Trigger	(selected)
Software Trigger	OFF, 50% min AD saturation
Hardware Trigger	OFF, Rising Edge
Single Pulse	100ms Target Delay
Repetitive Pulses	1.000kHz Rep. Rate

Chapter 10 Maintenance and Service

Protect the Beam Profiler from adverse environmental conditions. The Beam Profiler is not water resistant.

Attention

To avoid damage to the instrument, do not expose it to spray, liquids or solvents!

The unit does not need a regular maintenance by the user.

The BC207 and BC210C Series does not contain any modules that could be repaired by the user himself. If a malfunction occurs, please contact [Thorlabs](https://www.thorlabs.com) first. If necessary, you will be provided with the required return information.

Do not remove covers!

10.1 Version

The menu entry **Help** → **About Thorlabs** displays relevant Beam Software data.

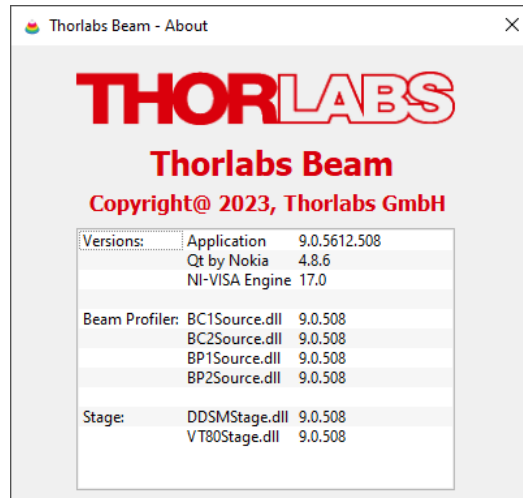

In case of a support request, please submit the software version of the application. This will help to locate the error.

10.2 Cleaning

Please clean the glass window which protects the sensor with compressed air or ethanol and cleaning tissues, only.

ND Filters

ND filters (see [Filter Wheel](#)) can be cleaned by conventional methods using pure ethanol and/or cleaning tissue. You may clean the front surface of the ND filters without unscrewing the appropriate filter holder. After tissue cleaning, it is recommended to remove remaining lint using compressed air.

In case dust is still visible within the camera image, unscrew the filter holder and clean the ND filter's rear surface. In addition, remove dust from the sensor itself (compressed air only!).

The outer surfaces of the instrument may be cleaned using a wet lint-free cloth.

10.3 Troubleshooting

❑ Software Installation failed

In order to install the Beam Software on your PC, you need administrator privileges. Otherwise, an installation is impossible. If you have trouble with software installation, please contact your system administrator.

❑ No Beam Profiler recognized

If after starting of Beam Software no instrument was recognized, the Device Settings button in the Menu bar is crossed out ()

- Check if you have connected a BC207 or BC210C Series instrument.
- Check the USB cable. Make sure you are using the supplied with instrument cable.
- Check proper driver installation
- Check if the green LED lights up - LED off indicates that the Beam Profiler's firmware was not loaded.

See section [Connection to the PC](#)^[24] for details.

You may unplug and reconnect the Beam Profiler to a different USB port or use a different USB cable. Wait a few seconds, until the green LED lights up. Then click "**Refresh Device List**" within the Device Selection panel. See chapter Start the Application for a detailed description.

❑ Fixed sample image instead of live camera image

The Beam Software selects a stored camera image automatically if no camera is found during program start. This is indicated by the image name in the status bar.



- Connect a BC207 or BC210C Beam Profiler to the PC and wait a few seconds until its LED lights up green.
- Click '**Refresh Device List**' in the Device Selection panel.
- Select the instrument and click 'Close'

See chapter Start the Application for a detailed description.

❑ Erroneous or no measurement results

- Remove the protection cap from the used ND filter.
- Verify that the beam under test enters the aperture of the Beam Profiler.
- Check if the power level is within the measurable [Power Range](#)^[159].
- Check Exposure Time and Gain settings. Choose '**Auto Exposure Control**' in Device Settings.
- Observe **error messages** in the status bar. Ambient light power may be too high or beam power too low or high. See [Warnings and Errors](#)^[165].

❑ Results and graphs are not being updated

- The device is in the pause mode. Resume the device by clicking the Start  button in the Menu bar.
- **Max Hold**  was activated - switch off **Max Hold** mode by clicking the  icon.
- The "**Average over frame**" rate might be high, check its value in the [Beam Settings panel](#)^[52].
- You may have activated the '**Software Trigger**' mode but the 'Min. Image Saturation' limit is not reached. Increase Exposure Time or even Gain to achieve a sufficiently high pulse intensity.
- The '**Hardware Trigger**' mode may be activated but no TTL trigger pulse is launched into the BNC or SMA input jack. Provide a [trigger signal](#)^[15].

❑ Menu, toolbar and setting controls react slowly

- The performance of your PC's graphics adapter may be too poor. Particularly, the 3D Profile window is resource-consuming at high resolution, which can decrease its update rate significantly. See [System Requirements](#)⁵.
- The AD converter was set to Precision mode (12 bit data).

10.3.1 Warnings and Errors

Warnings and error messages will appear in the status bar as soon as improper measurement conditions are detected. For this reason, please keep always an eye on the status bar in order to prevent measurement errors. Below some examples are shown:

 Power too high, camera saturated! Attenuation: 40 dB | Exposure Time: 9.93 ms | Gain: 1.20 x | Auto Exposure: OFF | 8.17 fps

❑ Power too high, camera saturated!

Explanation: Some pixels within the selected ROI or Calculation Area are saturated because they reach the maximum digit value 4095 in Precision Mode (12 bit data). Therefore, the local beam intensity may be even higher than displayed. Beam parameters cannot be calculated correctly!

Resolving: Decrease Exposure Time and Gain settings or reduce the beam intensity using a higher attenuation ND filter of the [Filter Wheel](#)⁹. You may also cascade two filters. If Exposure Control is set to Auto, a short appearance of this error is harmless as Exposure Time and Gain will be adjusted automatically.

Power too low!

Explanation The brightest pixel values fall below 10% of the available saturation range. This means that 90% of the available dynamic range remains unused. This causes a digitizing noise that increases the measurement noise.

Resolving Increase Exposure Time and Gain settings or increase the beam intensity using a lower attenuation ND filter of the [Filter Wheel](#)⁹. You may also remove the filter.

❑ High ambient power level!

Explanation The lowest pixel intensity within the selected camera ROI or Calculation Area is too high. Therefore, the beam edges cannot be detected or distinguished from a constant ambient light level. The reasons are either the laser beam diameter is wider than the chosen ROI or the ambient light is too high. Beam parameters cannot be calculated correctly!

Resolving Select the ROI so that its height and width is at least twice the beam diameter. Reduce the influence of ambient light by proper shielding, alternatively select a higher attenuation out of the [Filter Wheel](#)⁹ and increase the beam power.

Attention

As soon as an error or warning is displayed in the status bar, the calculated beam parameters are not reliable!

Chapter 11 Compatibility with Older Hardware

The Beam Software is downwards compatible with the following discontinued hardware components:

- BC106N-UV, BC106N-VIS (Camera Beam Profiler)

Electrical connections and mechanical setup should be carried out as described in the appropriate documentation to this hardware, while operation is described in the manual on hand.

Older documentation can be downloaded from the Thorlabs Manual Archive at www.thorlabs.com/manuals.cfm. Open this page and enter the desired item number; be careful about correct spelling.

Chapter 12 List of Acronyms

The following acronyms and abbreviations are used in this manual:

2D	<u>2</u> Dimensional
3D	<u>3</u> Dimensional
ADC	<u>A</u> nalog to <u>D</u> igital <u>C</u> onverter
AL	<u>A</u> luminum
AR	<u>A</u> nti <u>R</u> eflection
BC	<u>B</u> eam Profiler <u>C</u> amera
CA	<u>C</u> alculation <u>A</u> rea
cw	<u>C</u> ontinuous <u>W</u> ave (constant power source)
GUI	<u>G</u> raphical <u>U</u> ser <u>I</u> nterface
ND	<u>N</u> eutral <u>D</u> ensity
PC	<u>P</u> ersonal <u>C</u> omputer
FPS	<u>F</u> rames <u>P</u> er <u>S</u> econd
ROI	<u>R</u> egion <u>O</u> f <u>I</u> nterest
USB	<u>U</u> niversal <u>S</u> erial <u>B</u> us
UV	<u>U</u> ltra <u>V</u> iolet (wavelength range)
VIS	<u>V</u> ISible (wavelength range)

Chapter 13 Application Note

This chapter contains some background information about the measurement methods of beam profiles.

Beam profiles can be characterized by a number of different parameters. We aim to offer a software that allows to measure all usual beam parameters based on ISO11146-1 standard.

In the following sections detailed explanations are given to the measured parameters.

13.1 Ambient Light Correction

Thorlabs Beam Software implements a unique Ambient Light Correction (ALC) method. The procedure can be started from the Beam Settings panel, topic "[Optical Setup](#)⁴⁰".

After the laser beam has been blocked and only ambient light enters the sensor, the ALC records a number of images at different exposure times and averages them. Intermediate values are interpolated. This allows a precise calculation of the camera's baseline with ambient light valid at different exposure times.

An outstanding property of the ALC is that the original baseline of the camera (black level) is corrected for the average intensity of the ambient light "noise". This turns out to be a significant advantage, particularly for M^2 measurements - the 4σ values can be determined with a higher accuracy, as in this case the interference caused by ambient light is nearly eliminated.

13.2 Coordinate Systems

Lab System

The lab system (AKA reference system) of coordinates is based on the true X and Y coordinate orientation of the CMOS camera chip (X = lines, Y = columns).

Transformed System

The transformed system of coordinates is based on the calculated beam axes (minor and major axes for elliptical fit or for 4σ beam diameter).

13.3 Raw Data Measurements

Lab (or Reference or Sensor) Coordinate System

4s Beam Width is the width of a beam in **X** and **Y** axes (centroids), derived from the second moment calculation:

$$d_{\sigma x} = 4 * \sigma_x \quad d_{\sigma y} = 4 * \sigma_y$$

where σ_x and σ_y are the standard deviation of the horizontal or vertical marginal distribution, respectively:

$$\sigma_x = \sqrt{\frac{\sum [(x - x_{centroid})^2 * p(x, y)]}{Sum_Intensity}}$$

$$\sigma_y = \sqrt{\frac{\sum [(y - y_{centroid})^2 * p(x, y)]}{Sum_Intensity}}$$

and

$$\sigma_{xy} = \sqrt{\frac{\sum [(x - x_{centroid}) * (y - y_{centroid}) * p(x, y)]}{Sum_Intensity}}$$

Note

The **4s Beam Width** measurement is not in conformity with ISO11146! In accordance with ISO11146-3, beam diameters shall be defined at a $1/e^2$ clip level for Slit Beam Profilers, while for Camera Beam Profilers the $4\sigma_X'$ and $4\sigma_Y'$ beam widths apply.

Transformed Coordinate system

According to ISO11146-1, the second moment beam widths are calculated in the transformed coordinate system that follows the elliptical fit ($4\sigma_X'$ and $4\sigma_Y'$ beam width). Here, the following formulas are used:

$$d_{\sigma x'} = 2\sqrt{2} * \sqrt{(\sigma_x^2 + \sigma_y^2) + \gamma \sqrt{(\sigma_x^2 - \sigma_y^2)^2 + 4(\sigma_{xy}^2)^2}}$$

$$d_{\sigma y'} = 2\sqrt{2} * \sqrt{(\sigma_x^2 + \sigma_y^2) - \gamma \sqrt{(\sigma_x^2 - \sigma_y^2)^2 + 4(\sigma_{xy}^2)^2}}$$

where the coefficient

$$\gamma = \text{sgn}(\sigma_x^2 - \sigma_y^2)$$

The azimuthal angle is calculated by the formula

$$\varphi = \frac{1}{2} \arctan\left(\frac{2\sigma_{xy}^2}{\sigma_x^2 - \sigma_y^2}\right)$$

According to ISO11146-1, if the [ellipticity](#)^[17] is larger than 0.87, the beam profile may be considered to be of circular symmetry at that measuring location. In this case, ISO11146-1 allows the calculation of only one common 4σ beam width (4σ simplified).

Beam Diameter (4σ simplified) is the diameter derived from the second moment calculation on radial distance (pixel-centroid):

$$d_{\sigma} = 2\sqrt{2} * \sqrt{(\sigma_x^2 + \sigma_y^2)}$$

Effective Beam Diameter is the diameter of an equivalent circular beam area, within which the pixel intensities are above a level X (in per cent of the peak intensity = clip level):

$$D_{eff} = \sqrt{\frac{4 * N * A_{pix}}{\pi}}$$

with

N number of pixels with intensities above clip level

A_{pix} pixel size (for BC207 and BC210C = $3.45 * 3.45 \mu\text{m}^2$)

Peak Position

X, Y: position of the pixel with highest intensity (AD value) which is found first with respect to reference position.

$$R = \sqrt{X^2 + Y^2}$$

is the dial distance of peak position's pixel from the reference position (= sensor center).

Centroid Position

X, Y and R position (first moment), calculated over all pixels with respect to the above reference position.

$$X = \text{SUM} [x * p(x,y)] / I \quad Y = \text{SUM} [y * p(x,y)] / I$$

where:

$p(x,y)$ intensity at location (x,y);

I total intensity;

SUM of pixels taken over the entire area

AD Saturation

Saturation level of the instrument's AD converter. For a good SNR (signal-to-noise ratio) the saturation level should be not below 40% and not be above 95%.

Total Power

Total power within the [Calculation Area](#)^[50].

Peak Density

Power on peak pixel divided by its area (in μm^2)

13.4 Ellipse (Fitted)

The beam shape is fit to an ellipse using the set clip level.

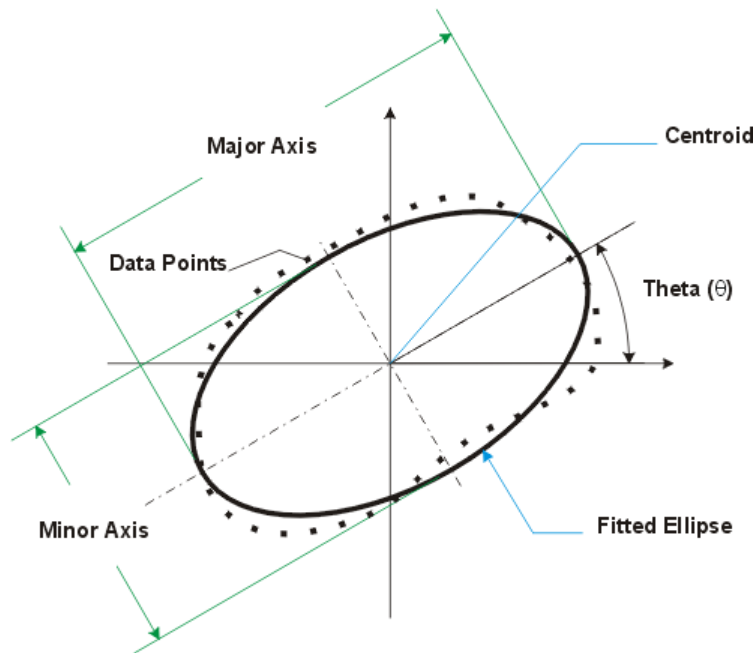

Diameter (clip level) is given for the minor axis (**min**), major axis (**max**) and their arithmetic **mean** value.

Ellipticity and **Eccentricity** of the beam are defined in ISO 11146-1 as

$$\text{Ellipticity} = \frac{d_{\min}}{d_{\max}} \quad \text{Eccentricity} = \frac{\sqrt{d_{\max}^2 - d_{\min}^2}}{d_{\max}}$$

with d_{\min} = minor axis and d_{\max} = major axes of the approximated beam ellipse.

Orientation denotes the angle θ between the major ellipse axis and the horizontal X axis. Range: $-90^\circ < \theta \leq 90^\circ$.

13.5 X-Y-Profile Measurement

Beam Width at Clip Level (xx%)

Beam width is the distance between the two points where the opposite edges of a captured beam profile are bisected by the X or Y axis and the intensity falls to a certain percentage of the peak power. This percentage is called clip level.

Preferred clip levels are for instance 50 % (Full Width at Half Maximum) and 13.53% (exactly $1/e^2$). Since the Beam Software supports a variable clip level, the beam width is always displayed with its clip level in brackets.

Note

Please note that "Beam Width" is always the diameter, not the radius of the beam.

13.6 Gaussian Fit Measurement

The beam profiles of coherent light sources, such as lasers and the output of fibers, show a distribution more or less close to Gaussian. If focusing a Gaussian beam, it converges into a waist, after which it diverges.

The Gaussian fit uses the method of least squares in order to fit the X and Y cross section profile of a beam to a Gaussian shape. In other words, the Gaussian fit represents an approximation of captured measurement data to a Gaussian distribution.

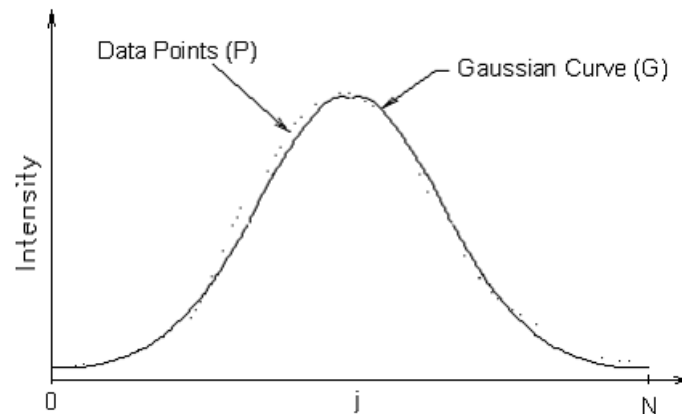

Gaussian Intensity is the intensity distribution of the Gaussian fitted beam profile.

Gaussian Diameter is the width of the Gaussian fitted profile at a $1/e^2$ intensity clip level.

13.7 Bessel Fit

One of the most important properties of a Bessel beam is that it is non-diffractive. This means, apart from Gaussian beams, their shape does not change during propagation, and they do not have a focus in terms of a location with highest intensity along the propagation direction. Its distribution can be described by a Bessel function of the first kind.

Ideal Bessel beams do not exist, but a good approximation - a Bessel-Gauss beam - can be achieved by focusing a Gaussian beam using an axicon lens, a narrow annular aperture, or a axisymmetric diffraction grating. The output of some step index fibers can also have a profile close to a Bessel beam.

The Bessel fit approximates a given beam profile to a Bessel function distribution.

Chapter 14 Certifications and Compliances

EU Declaration of Conformity
in accordance with EN ISO 17050-1:2010

We: Thorlabs GmbH
Of: Münchner Weg 1, 85232 Bergkirchen, Deutschland

in accordance with the following Directive(s):

2014/30/EU	Electromagnetic Compatibility (EMC) Directive
2011/65/EU	Restriction of Use of Certain Hazardous Substances (RoHS)

hereby declare that:
Model: **BC207UV(/M)(-M2MS), BC207VIS(/M)(-M2MS)**

Equipment: **CMOS Camera Beam Profiler Family**

is/are in conformity with the applicable requirements of the following documents:

EN 61326-1	Electrical Equipment for Measurement, Control and Laboratory Use - EMC Requirements	2013
EN 61010-1	Safety Requirements for Electrical Equipment for Measurement, Control and Laboratory Use	2010

and which, issued under the sole responsibility of Thorlabs, is/are in conformity with Directive 2011/65/EU of the European Parliament and of the Council of 8th June 2011 on the restriction of the use of certain hazardous substances in electrical and electronic equipment, for the reason stated below:

contains no substances in excess of the maximum concentration values tolerated by weight in homogenous materials as listed in Annex II of the Directive

I hereby declare that the equipment named has been designed to comply with the relevant sections of the above referenced specifications, and complies with all applicable Essential Requirements of the Directives.

Signed:  **On:** 04 August 2021

Name: Dr. Bruno Gross
Position: General Manager

CE
EDC - BC207UV(/M)(-M2MS), BC20...

EU Declaration of Conformity
in accordance with EN ISO 17050-1:2010

We: Thorlabs GmbH
Of: Münchner Weg 1, 85232 Bergkirchen, Deutschland

in accordance with the following Directive(s):

2014/30/EU	Electromagnetic Compatibility (EMC) Directive
2011/65/EU	RoHS, including 2015/863

hereby declare that:
Model: BC210CV(/M), BC210CU(/M)

Equipment: CMOS Camera Beam Profiler Family

is/are in conformity with the applicable requirements of the following documents:

EN 61326-1	Electrical Equipment for Measurement, Control and Laboratory Use - EMC Requirements	2021
EN IEC 63000	Technical documentation for the assessment of electrical and electronic products with respect to the restriction of hazardous substances	2018
EN 61010-1	Safety Requirement for Electrical Equipment for Measurement, Control and Laboratory Use	2019

and which, issued under the sole responsibility of Thorlabs, is/are in conformity with Directive 2011/65/EU of the European Parliament and of the Council of 8th June 2011 on the restriction of the use of certain hazardous substances in electrical and electronic equipment, for the reason stated below:

I hereby declare that the equipment named has been designed to comply with the relevant sections of the above referenced specifications, and complies with all applicable Essential Requirements of the Directives.

Signed:  **On:** 25 May 2023

Name: Julien Vigroux
Position: General Manager

CE
 EDC - BC210CV(/M), BC210CU(/...

Chapter 15 Warranty and RMA Information

Thorlabs warrants material and production of the BC207 and BC210C Series for a period of 24 months starting with the date of shipment in accordance with and subject to the terms and conditions set forth in Thorlabs' General Terms and Conditions of Sale which can be found at:

General Terms and Conditions:

https://www.thorlabs.com/Images/PDF/LG-PO-001_Thorlabs_terms_and_%20agreements.pdf

and

https://www.thorlabs.com/images/PDF/Terms%20and%20Conditions%20of%20Sales_Thorlabs-GmbH_English.pdf

15.1 Return of Devices

This precision device is only serviceable if returned and properly packed into the complete original packaging including the complete shipment plus the cardboard insert that holds the enclosed devices. If necessary, ask for replacement packaging. Refer servicing to qualified personnel.

15.2 WEEE Policy

Thorlabs 'End of Life' Policy (WEEE)

Thorlabs verifies our compliance with the WEEE (Waste Electrical and Electronic Equipment) directive of the European Community and the corresponding national laws. Accordingly, all end users in the EC may return "end of life" Annex I category electrical and electronic equipment sold after August 13, 2005 to Thorlabs, without incurring disposal charges. Eligible units are marked with the crossed out "wheelie bin" logo (see right), were sold to and are currently owned by a company or institute within the EC, and are not disassembled or contaminated. Contact Thorlabs for more information. Waste treatment is your own responsibility. "End of life" units must be returned to Thorlabs or handed to a company specializing in waste recovery. Do not dispose of the unit in a litter bin or at a public waste disposal site. It is the user's responsibility to delete all private data stored on the device prior to disposal.

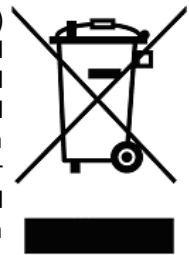

Chapter 16 Manufacturer Address

Manufacturer Address Europe
 Thorlabs GmbH
 Münchner Weg 1
 D-85232 Bergkirchen
 Germany
 Tel: +49-8131-5956-0
 Fax: +49-8131-5956-99
www.thorlabs.de
 Email: europe@thorlabs.com

EU-Importer Address
 Thorlabs GmbH
 Münchner Weg 1
 D-85232 Bergkirchen
 Germany
 Tel: +49-8131-5956-0
 Fax: +49-8131-5956-99
www.thorlabs.de
 Email: europe@thorlabs.com

UK-Importer Address
 Thorlabs, LTD.
 204 Lancaster Way Business Park
 Ely, CB6 3NX
 UK
 Tel: +44-1353-654440
 Fax: +44 (0)1353-654444
www.thorlabs.com
 Email: techsupport.uk@thorlabs.com

Chapter 17 Copyright and Exclusion of Liability

Thorlabs has taken every possible care in preparing this document. We however assume no liability for the content, completeness or quality of the information contained therein. The content of this document is regularly updated and adapted to reflect the current status of the product.

All rights reserved. This document may not be reproduced, transmitted or translated to another language, either as a whole or in parts, without the prior written permission of Thorlabs. Copyright © Thorlabs 2023. All rights reserved.

Please refer to the general terms and conditions linked under [Warranty](#)¹⁷⁵.

Chapter 18 Thorlabs Worldwide Contacts

For technical support or sales inquiries, please visit us at www.thorlabs.com/contact for our most up-to-date contact information.



USA, Canada, and South America

Thorlabs, Inc.
sales@thorlabs.com
techsupport@thorlabs.com

UK and Ireland

Thorlabs Ltd.
sales.uk@thorlabs.com
techsupport.uk@thorlabs.com

Europe

Thorlabs GmbH
europa@thorlabs.com

Scandinavia

Thorlabs Sweden AB
scandinavia@thorlabs.com

France

Thorlabs SAS
sales.fr@thorlabs.com

Brazil

Thorlabs Vendas de Fotônicos Ltda.
brasil@thorlabs.com

Japan

Thorlabs Japan, Inc.
sales@thorlabs.jp

China

Thorlabs China
chinasales@thorlabs.com



THORLABS
www.thorlabs.com
